

SN54HC194, SN74HC194 4-BIT BIDIRECTIONAL UNIVERSAL SHIFT REGISTERS

D2684, DECEMBER 1982—REVISED SEPTEMBER 1987

- Parallel Inputs and Outputs
- Four Operating Modes:
Synchronous Parallel Load
Right Shift
Left Shift
Do Nothing
- Positive Edge-Triggered Clocking
- Direct Overriding Clear
- Package Options: Plastic and Ceramic DIPs,
Plastic Small-Outline Packages, and Ceramic
Chip Carriers
- Dependable Texas Instruments Quality and
Reliability

description

These bidirectional shift registers are designed to incorporate virtually all of the features a system designer may want in a shift register. The circuit features parallel inputs, parallel outputs, right-shift and left-shift inputs, operating-mode-control inputs, and a direct overriding clear line. The register has four distinct modes of operation, namely:

- Parallel (broadside) load
- Shift right (in the direction Q_A toward Q_D)
- Shift left (in the direction Q_D toward Q_A)
- Inhibit clocking (do nothing).

Synchronous parallel loading is accomplished by applying the 4 bits of data and taking both mode control inputs, S_0 and S_1 , high. The data are loaded into the associated flip-flops and appear at the outputs after the positive transition of the clock input. During loading, serial data flow is inhibited.

Shift right is accomplished synchronously with the rising edge of the clock pulse when S_0 is high and S_1 is low. Serial data for this mode is entered at the shift-right data input. When S_0 is low and S_1 is high, data shifts left synchronously, and new data is entered at the shift-left serial input.

Clocking of the shift register is inhibited when both mode control inputs are low.

The SN54HC194 is characterized for operation over the full military temperature range of -55°C to 125°C . The SN74HC194 is characterized for operation from -40°C to 85°C .

SN54HC194 . . . J PACKAGE
SN74HC194 . . . DW or N PACKAGE
(TOP VIEW)

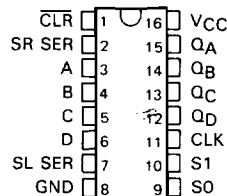

SN54HC194 . . . FK PACKAGE
(TOP VIEW)

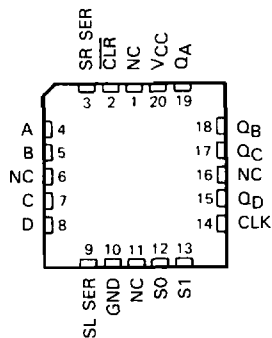

NC—No internal connection

logic symbol†

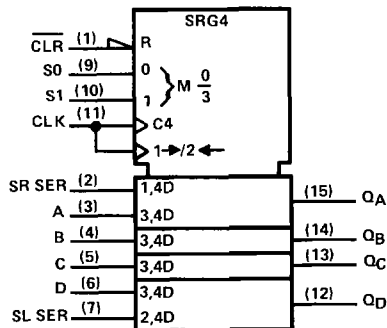

† This symbol is in accordance with ANSI/IEEE Std 91-1984 and IEC Publication 617-12.
Pin numbers shown are for DW, J, and N packages.

PRODUCTION DATA documents contain information current as of publication date. Products conform to specifications per the terms of Texas Instruments standard warranty. Production processing does not necessarily include testing of all parameters.

TEXAS
INSTRUMENTS

POST OFFICE BOX 655012 • DALLAS, TEXAS 75265

Copyright © 1982, Texas Instruments Incorporated

2-263

SN54HC194, SN74HC194
4-BIT BIDIRECTIONAL UNIVERSAL SHIFT REGISTERS

logic diagram (positive logic)

2
HCMOS Devices

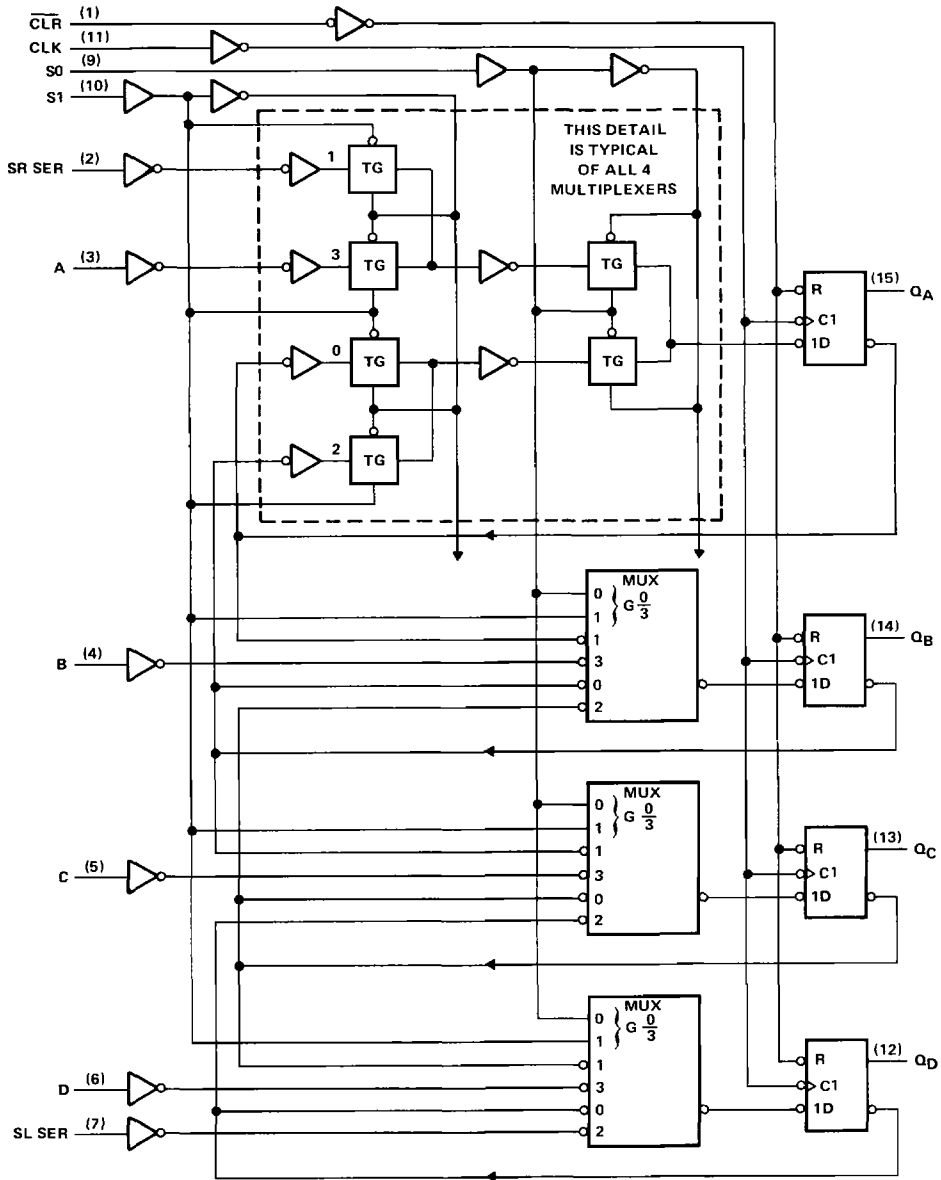

Pin numbers shown are for DW, J, and N packages.

SN54HC194, SN74HC194 4-BIT BIDIRECTIONAL UNIVERSAL SHIFT REGISTERS

FUNCTION TABLE

CLEAR	MODE		CLOCK	INPUTS				OUTPUTS					
	S1	S0		SERIAL		PARALLEL				Q _A	Q _B	Q _C	Q _D
				LEFT	RIGHT	A	B	C	D				
L	X	X	X	X	X	X	X	X	L	L	L	L	
H	X	X	L	X	X	X	X	X	X	Q _{A0}	Q _{B0}	Q _{C0}	Q _{D0}
H	H	H	I	X	X	a	b	c	d	a	b	c	d
H	L	H	I	X	H	X	X	X	X	H	Q _{An}	Q _{Bn}	Q _{Cn}
H	L	H	I	X	L	X	X	X	X	L	Q _{An}	Q _{Bn}	Q _{Cn}
H	H	L	I	H	X	X	X	X	X	Q _{Bn}	Q _{Cn}	Q _{Dn}	H
H	H	L	I	L	X	X	X	X	X	Q _{Bn}	Q _{Cn}	Q _{Dn}	L
H	L	L	X	X	X	X	X	X	X	Q _{An}	Q _{Bn}	Q _{Cn}	Q _{D0}

typical clear, load, right-shift, left-shift, inhibit, and clear sequences

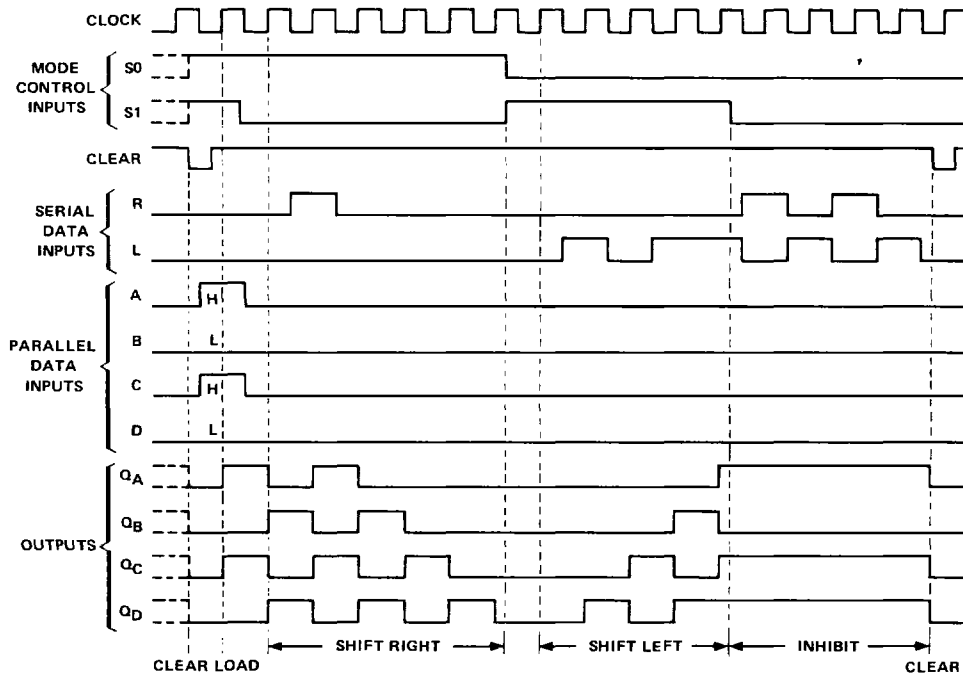

SN54HC194, SN74HC194

4-BIT BIDIRECTIONAL UNIVERSAL SHIFT REGISTERS

absolute maximum ratings over operating free-air temperature range†

Supply voltage, V_{CC}	-0.5 V to 7 V
Input clamp current, I_{IK} ($V_I < 0$ or $V_I > V_{CC}$)	± 20 mA
Output clamp current, I_{OK} ($V_O < 0$ or $V_O > V_{CC}$)	± 20 mA
Continuous output current, I_O ($V_O = 0$ to V_{CC})	± 25 mA
Continuous current through V_{CC} or GND pins	± 50 mA
Lead temperature 1,6 mm (1/16 in) from case for 60 s: FK or J package	300°C
Lead temperature 1,6 mm (1/16 in) from case for 10 s: DW or N package	260°C
Storage temperature range	-65°C to 150°C

†Stresses beyond those listed under "absolute maximum ratings" may cause permanent damage to the device. These are stress ratings only, and functional operation of the device at these or any other conditions beyond those indicated under "recommended operating conditions" is not implied. Exposure to absolute-maximum-rated conditions for extended periods may affect device reliability.

recommended operating conditions

		SN54HC194			SN74HC194			UNIT
		MIN	NOM	MAX	MIN	NOM	MAX	
V_{CC} Supply voltage		2	5	6	2	5	6	V
V_{IH} High-level input voltage	$V_{CC} = 2$ V	1.5			1.5			V
	$V_{CC} = 4.5$ V	3.15			3.15			
	$V_{CC} = 6$ V	4.2			4.2			
V_{IL} Low-level input voltage	$V_{CC} = 2$ V	0		0.3	0		0.3	V
	$V_{CC} = 4.5$ V	0		0.9	0		0.9	
	$V_{CC} = 6$ V	0		1.2	0		1.2	
V_I Input voltage		0		V_{CC}	0		V_{CC}	V
V_O Output voltage		0		V_{CC}	0		V_{CC}	V
t_t Input transition (rise and fall) times	$V_{CC} = 2$ V	0		1000	0		1000	ns
	$V_{CC} = 4.5$ V	0		500	0		500	
	$V_{CC} = 6$ V	0		400	0		400	
T_A Operating free-air temperature		-55		125	-40		85	°C

electrical characteristics over recommended operating free-air temperature range (unless otherwise noted)

PARAMETER	TEST CONDITIONS	V_{CC}	$T_A = 25^\circ\text{C}$			SN54HC194		SN74HC194		UNIT
			MIN	TYP	MAX	MIN	MAX	MIN	MAX	
V_{OH}	$V_I = V_{IH}$ or V_{IL} , $I_{OH} = -20 \mu\text{A}$	2 V	1.9	1.998		1.9		1.9	V	
		4.5 V	4.4	4.499		4.4		4.4		
		6 V	5.9	5.999		5.9		5.9		
V_{OL}	$V_I = V_{IH}$ or V_{IL} , $I_{OL} = 20 \mu\text{A}$	2 V	0.002	0.1		0.1		0.1	V	
		4.5 V	0.001	0.1		0.1		0.1		
		6 V	0.001	0.1		0.1		0.1		
V_{OL}	$V_I = V_{IH}$ or V_{IL} , $I_{OL} = 4 \text{ mA}$	4.5 V	0.17	0.26		0.4		0.33	V	
		6 V	0.15	0.26		0.4		0.33		
		6 V	0.15	0.26		0.4		0.33		
I_I	$V_I = V_{CC}$ or 0	6 V	± 0.1	± 100		± 1000		± 1000	nA	
I_{CC}	$V_I = V_{CC}$ or 0, $I_O = 0$	6 V		8		160		80	μA	
C_i		2 to 6 V		3	10		10	10	pF	

2

HCMOS Devices

SN4HC194, SN74HC194 4-BIT BIDIRECTIONAL UNIVERSAL SHIFT REGISTERS

timing requirements over recommended operating free-air temperature range (unless otherwise noted)

		V _{CC}	T _A = 25°C			SN54HC194		SN74HC194		UNIT
			MIN	TYP	MAX	MIN	MAX	MIN	MAX	
f _{clock}	Clock frequency	2 V	0	6	0	4.2	0	5	MHz	
		4.5 V	0	31	0	21	0	25		
		6 V	0	36	0	25	0	29		
t _w	CLK high or low	2 V	80		120		100	ns		
		4.5 V	16		24		20			
		6 V	14		20		17			
	CLR low	2 V	80		120		100			
		4.5 V	16		24		20			
		6 V	14		20		17			
t _{su}	Setup time, any input before CLK†	2 V	100		150		125	ns		
		4.5 V	20		30		25			
		6 V	17		26		21			
t _h	Hold time, data after CLK†	2 V	0		0		0	ns		
		4.5 V	0		0		0			
		6 V	0		0		0			

switching characteristics over recommended operating free-air temperature range (unless otherwise noted), C_L = 50 pF (see Note 1)

PARAMETER	FROM (INPUT)	TO (OUTPUT)	V _{CC}	T _A = 25°C			SN54HC194		SN74HC194		UNIT
				MIN	TYP	MAX	MIN	MAX	MIN	MAX	
f _{max}			2 V	6			4.2		5	MHz	
			4.5 V	31			21		25		
			6 V	36			25		29		
t _{PHL}	CLR	Any	2 V		67	150		225		190	ns
			4.5 V		17	30		45		38	
			6 V		14	26		37		31	
t _{pd}	CLK	Any	2 V		67	145		220		180	ns
			4.5 V		17	29		44		36	
			6 V		14	25		37		31	
t _t		Any	2 V		28	75		110		95	ns
			4.5 V		8	15		22		19	
			6 V		6	13		19		16	

C _{pd}	Power dissipation capacitance	No load, T _A = 25°C	65 pF typ
-----------------	-------------------------------	--------------------------------	-----------

NOTE 1: Load circuit and voltage waveforms are shown in Section 1.

2
HCMOS Devices