

HDSP-335x, HDSP-555x, HDSP-751x, HDSP-A10x, HDSP-A80x, HDSP-A90x, HDSP-E10x, HDSP-F10x, HDSP-H10x, HDSP-K12x, HDSP-N10x Series

Low-Current Seven-Segment Displays



Description

This Broadcom[®] family of low-current seven-segment displays is designed for applications requiring low power consumption. They are tested and selected for their excellent low-current characteristics to ensure that the segments are matched at low currents. Drive currents as low as 1 mA per segment are available.

Pin-for-pin equivalent displays are also available in a standard current or high light ambient design. The standard current displays are available in all colors and are ideal for most applications. The high light ambient displays are ideal for sunlight ambients or long string lengths. For additional information, see the 7.6-mm Micro Bright Seven-Segment Displays, 10-mm Seven-Segment Displays, 7.6-mm/10.9-mm Seven-Segment Displays, 14.2-mm Seven-Segment Displays (AV02-1107EN), 20-mm Seven-Segment Displays, or High Light Ambient Seven-Segment Displays data sheets.

Features

- Low power consumption
- Industry-standard size
- Industry-standard pinout
- Choice of character size: 7.6 mm (0.30 in), 10 mm (0.40 in), 10.9 mm (0.43 in), 14.2 mm (0.56 in), 20 mm (0.80 in)
- Choice of colors: AllnGaP deep red, AllnGaP red, AllnGaP yellow, AllnGaP green
- Excellent appearance
 - Evenly lighted segments
 - $\pm 50^\circ$ viewing angle
- Design flexibility
 - Common anode or common cathode
 - Single and dual digits
 - Left-hand and right-hand decimal points
 - ± 1 right-hand decimal overflow character
- Categorized for luminous intensity
 - Yellow and green categorized for color
 - Use of like categories yields a uniform display
- Excellent for long digit string multiplexing

Package Drawings

Figure 1: Package Dimensions, A to C

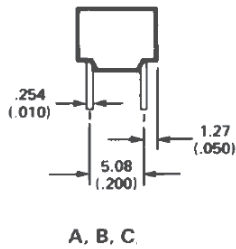
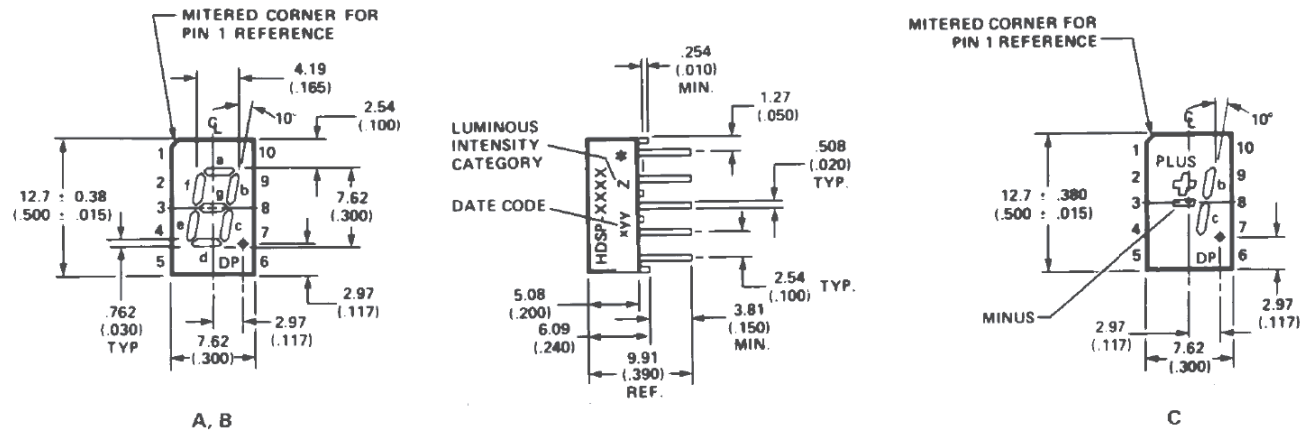

* Side View of package indicates Country of Origin

Pin	FUNCTION		
	A	B	C
1	ANODE ^[3]	CATHODE ^[4]	ANODE ^[3]
2	CATHODE f	ANODE f	CATHODE PLUS
3	CATHODE g	ANODE g	CATHODE MINUS
4	CATHODE e	ANODE e	NC
5	CATHODE d	ANODE d	NC
6	ANODE ^[3]	CATHODE ^[4]	ANODE ^[3]
7	CATHODE DP	ANODE DP	CATHODE DP
8	CATHODE c	ANODE c	CATHODE c
9	CATHODE b	ANODE b	CATHODE b
10	CATHODE a	ANODE a	NC

Notes:

1. All dimensions in millimeters (inches).
2. All untoleranced dimensions are for reference only.
3. Redundant anodes.
4. Redundant cathodes.

Figure 2: Package Dimensions, E to H

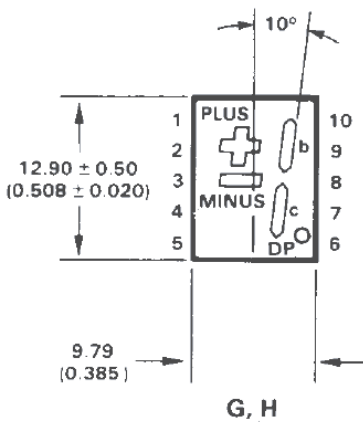
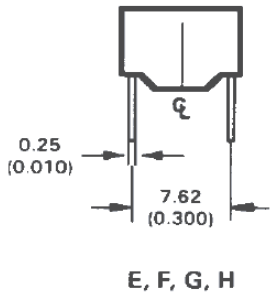
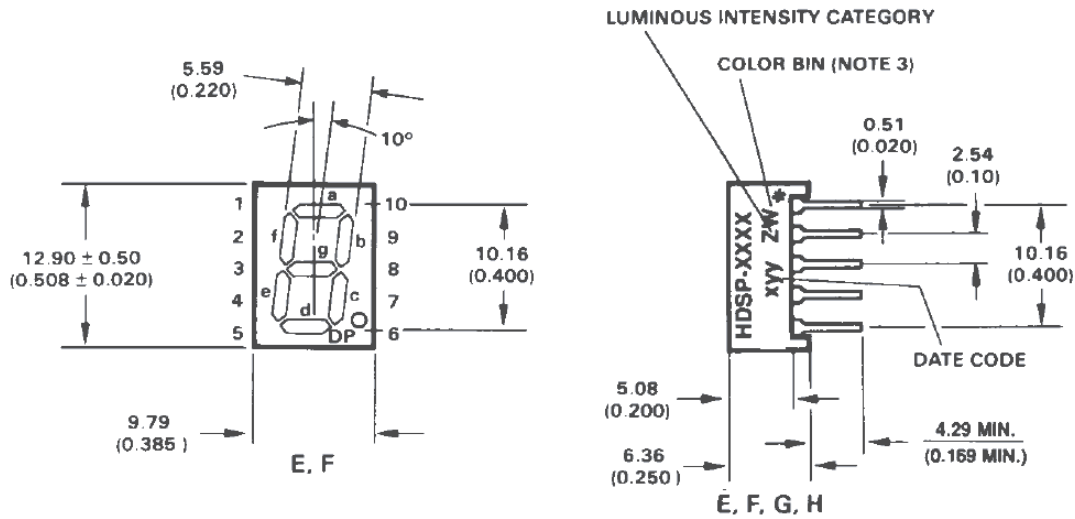

* Side View of package indicates Country of Origin

Pin	FUNCTION			
	E	F	G	H
1	ANODE ^[3]	CATHODE ^[4]	ANODE ^[3]	CATHODE ^[4]
2	CATHODE f	ANODE f	CATHODE PLUS	ANODE PLUS
3	CATHODE g	ANODE g	CATHODE MINUS	ANODE MINUS
4	CATHODE e	ANODE e	NC	NC
5	CATHODE d	ANODE d	NC	NC
6	ANODE ^[3]	CATHODE ^[4]	ANODE ^[3]	CATHODE ^[4]
7	CATHODE DP	ANODE DP	CATHODE DP	ANODE DP
8	CATHODE c	ANODE c	CATHODE c	ANODE c
9	CATHODE b	ANODE b	CATHODE b	ANODE b
10	CATHODE a	ANODE a	NC	NC

Notes:

1. All dimensions in millimeters (inches).
2. All untoleranced dimensions are for reference only.
3. Redundant anodes.
4. Redundant cathodes.

Figure 3: Package Dimensions, J to K

Pin	FUNCTION	
	J	K
1	CATHODE a	ANODE a
2	CATHODE f	ANODE f
3	ANODE [3]	CATHODE [6]
4	NO PIN	NO PIN
5	NO PIN	NO PIN
6	NO CONN. [5]	NO CONN. [5]
7	CATHODE e	ANODE e
8	CATHODE d	ANODE d
9	CATHODE dp	ANODE dp
10	CATHODE c	ANODE c
11	CATHODE g	ANODE g
12	NO PIN	NO PIN
13	CATHODE b	ANODE b
14	ANODE [3]	CATHODE [6]

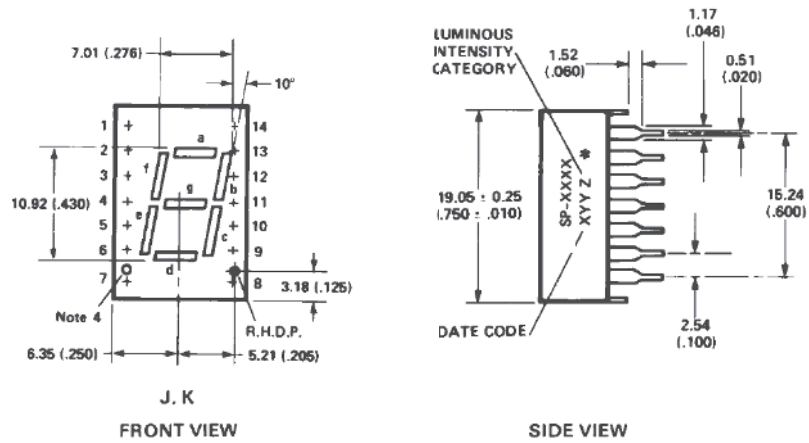

*Side View of package indicates Country of Origin

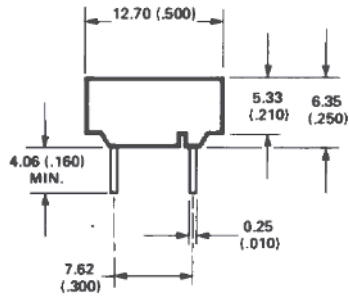

Notes:

1. All dimensions in millimeters (inches).
2. All untoleranced dimensions are for reference only.
3. Redundant anodes.
4. Unused dp position.
5. See internal circuit diagram.
6. Redundant cathodes.
7. See part number table for L.H.D.P. and R.H.D.P. designation.

Figure 4: Package Dimensions, M to N

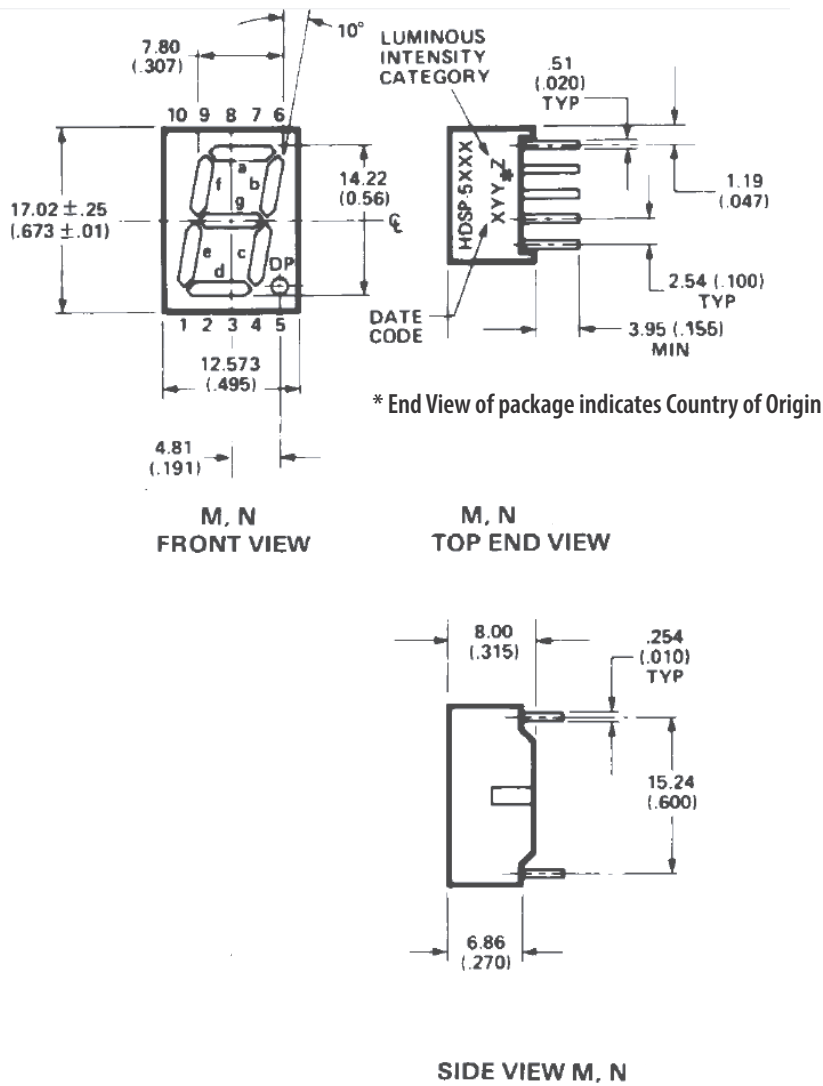

Pin	FUNCTION	
	M	N
1	CATHODE e	ANODE e
2	CATHODE d	ANODE d
3	ANODE ^[3]	CATHODE ^[4]
4	CATHODE c	ANODE c
5	CATHODE DP	ANODE DP
6	CATHODE b	ANODE b
7	CATHODE a	ANODE a
8	ANODE ^[3]	CATHODE ^[4]
9	CATHODE f	ANODE f
10	CATHODE g	ANODE g

Notes:

1. All dimensions in millimeters (inches).
2. All untoleranced dimensions are for reference only.
3. Redundant anodes.
4. Redundant cathodes.

Figure 5: Package Dimensions, T to U

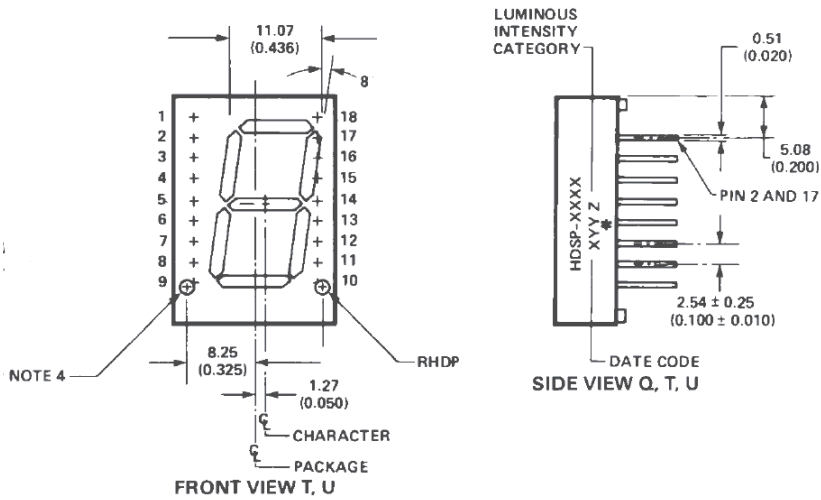

* The Side View of package indicates Country of Origin

Pin	FUNCTION	
	T	U
1	NO PIN	NO PIN
2	CATHODE a	ANODE a
3	CATHODE f	ANODE f
4	ANODE ^[3]	CATHODE ^[6]
5	CATHODE e	ANODE e
6	ANODE ^[3]	CATHODE ^[6]
7	NO CONNECT	NO CONNECT
8	NO PIN	NO PIN
9	NO PIN	NO PIN
10	CATHODE dp	ANODE dp
11	CATHODE d	ANODE d
12	ANODE ^[3]	CATHODE ^[6]
13	CATHODE c	ANODE c
14	CATHODE g	ANODE g
15	CATHODE b	ANODE b
16	NO PIN	NO PIN
17	ANODE ^[3]	CATHODE ^[6]
18	NO PIN	NO PIN

Notes:

1. All dimensions in millimeters (inches).
2. All untoleranced dimensions are for reference only.
3. Redundant anodes.
4. Unused dp position.
5. See internal circuit diagram.
6. Redundant cathodes.

Figure 6: Package Dimensions, R to S

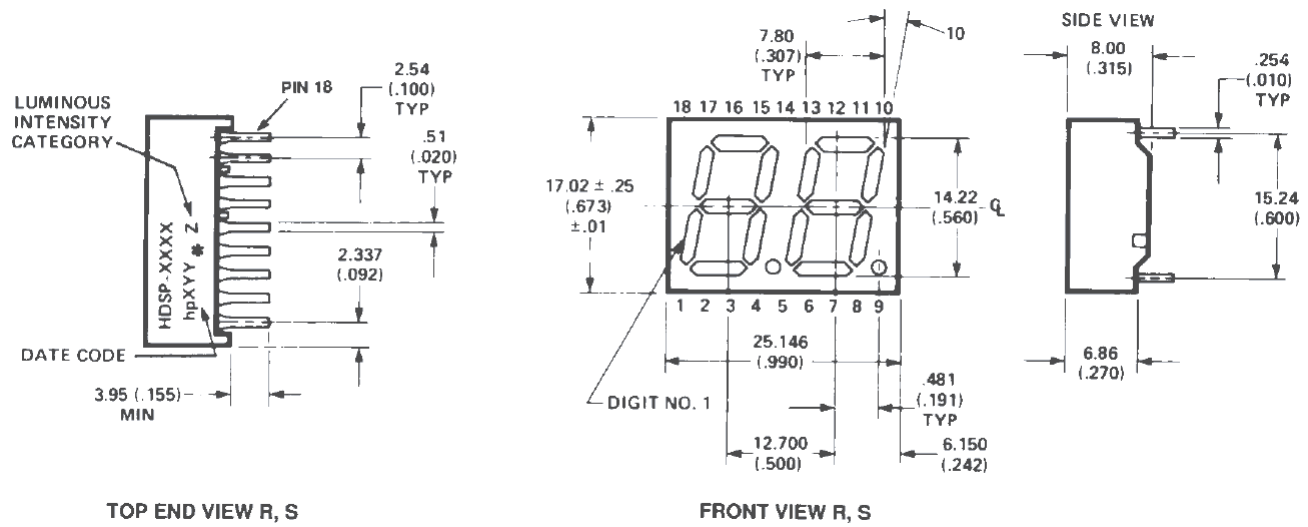

* The Side View of package indicates Country of Origin

Pin	FUNCTION	
	R	S
1	E CATHODE NO. 1	E ANODE NO. 1
2	D CATHODE NO. 1	D ANODE NO. 1
3	C CATHODE NO. 1	C ANODE NO. 1
4	DP CATHODE NO. 1	DP ANODE NO. 1
5	E CATHODE NO. 2	E ANODE NO. 2
6	D CATHODE NO. 2	D ANODE NO. 2
7	G CATHODE NO. 2	G ANODE NO. 2
8	C CATHODE NO. 2	C ANODE NO. 2
9	DP CATHODE NO. 2	DP ANODE NO. 2
10	B CATHODE NO. 2	B ANODE NO. 2
11	A CATHODE NO. 2	A ANODE NO. 2
12	F CATHODE NO. 2	F ANODE NO. 2
13	DIGIT NO. 2 ANODE	DIGIT NO. 2 CATHODE
14	DIGIT NO. 1 ANODE	DIGIT NO. 1 CATHODE
15	B CATHODE NO. 1	B ANODE NO. 1
16	A CATHODE NO. 1	A ANODE NO. 1
17	G CATHODE NO. 1	G ANODE NO. 1
18	F CATHODE NO. 1	F ANODE NO. 1

Notes:

1. All dimensions in millimeters (inches).
2. All untoleranced dimensions are for reference only.
3. Where applicable.

Internal Circuit Diagram

Figure 7: Internal Circuit Diagram

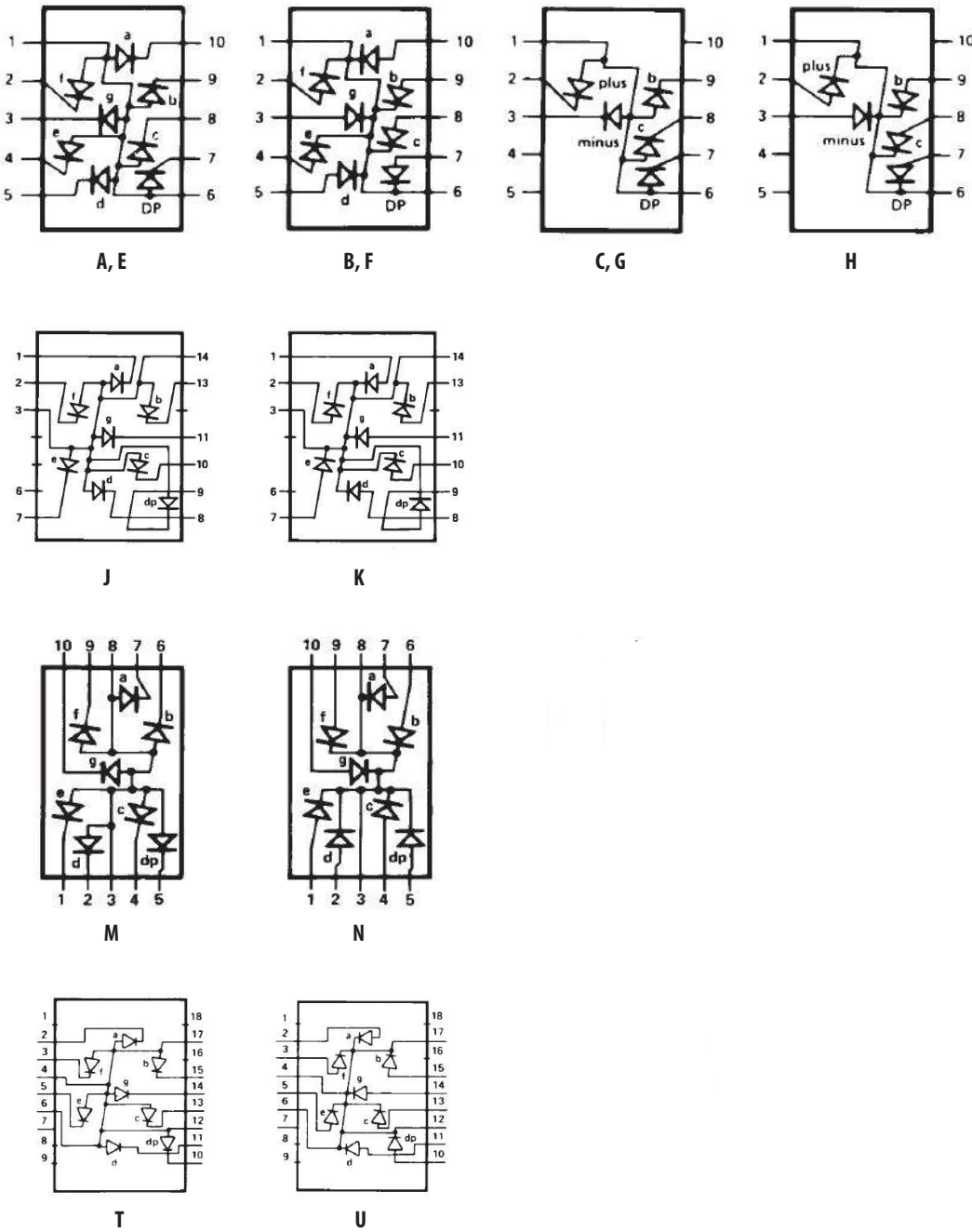
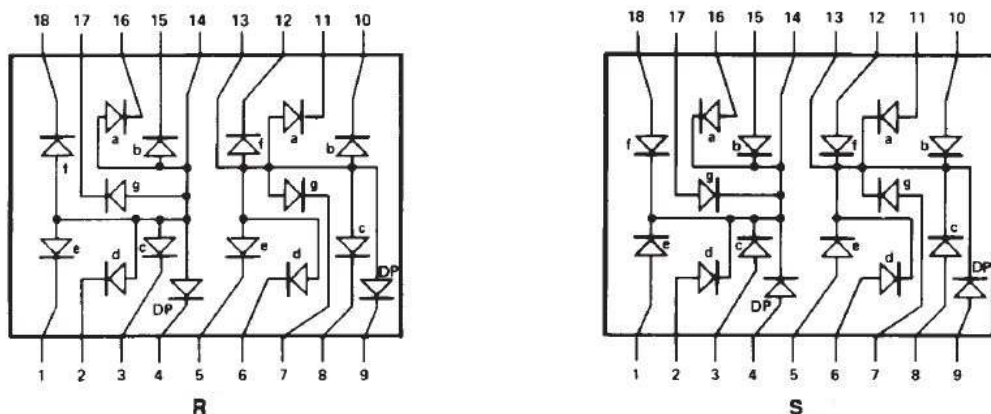

Figure 8: Internal Circuit Diagram, R to S



Device Selection Guide

AllnGaP Deep Red	AllnGaP Red	AllnGaP Yellow	AllnGaP Green	Description	Package Drawing
HDSP-A101	HDSP-7511	HDSP-A801	HDSP-A901	7.6-mm Common Anode Right-Hand Decimal	A
HDSP-A103	HDSP-7513	HDSP-A803	HDSP-A903	7.6-mm Common Cathode Right-Hand Decimal	B
HDSP-A107	HDSP-7517			7.6-mm Common Anode ± 1 Right-Hand Decimal Overflow	C
HDSP-F101				10-mm Common Anode Right-Hand Decimal	E
HDSP-F103				10-mm Common Cathode Right-Hand Decimal	F
HDSP-F107				10-mm Common Anode ± 1 Right-Hand Decimal Overflow	G
HDSP-F108				10-mm Common Cathode ± 1 Right-Hand Decimal Overflow	H
HDSP-E101	HDSP-3351			10.9-mm Common Anode Right-Hand Decimal	J
HDSP-E103	HDSP-3353			10.9-mm Common Cathode Right-Hand Decimal	K
HDSP-H101	HDSP-5551			14.2-mm Common Anode Right-Hand Decimal	M
HDSP-H103	HDSP-5553			14.2-mm Common Cathode Right-Hand Decimal	N
HDSP-K121				14.2-mm Two Digit Common Anode Right-Hand Decimal	R
HDSP-K123				14.2-mm Two Digit Common Cathode Right-Hand Decimal	S
HDSP-N101				20-mm Common Anode Right-Hand Decimal	T
HDSP-N103				20-mm Common Cathode Right-Hand Decimal	U

Absolute Maximum Ratings

Parameter	Deep Red HDSP-A10x/E10x/ H10x/K12x/N10x/ F10x Series	Red HDSP-751x/ 335x/555x Series	Yellow HDSP-A80x Series	Green HDSP-A90x Series	Unit
Power Dissipation per Segment or DP	37.5	37.5	37.5	37.5	mW
Peak Forward Current per Segment or DP ^a	90	90	60	90	mA
DC Forward Current per Segment or DP ^b	15	15	15	15	mA
Operating Temperature Range	-20 to +100	-40 to +100	-40 to +100	-40 to +100	°C
Storage Temperature Range	-55 to +100				°C
Reverse Voltage per Segment or DP ^c	3.0				V
Wave Soldering Temperature for 3 Seconds (1.60 mm [0.063 in.] below seating body)	250				°C

- a. Duty factor = 10%, frequency = 1 kHz, $T_A = 25^\circ\text{C}$.
 b. Derate linearly as shown in [Figure 12](#) (deep red), [Figure 16](#) (red), [Figure 20](#) (green), and [Figure 24](#) (yellow).
 c. Reverse voltage is for LED testing purposes and not recommended to be used as an application condition.

Electrical/Optical Characteristics ($T_A = 25^\circ\text{C}$)

Parameter	Symbol	Min.	Typ.	Max.	Unit	Test Conditions
Deep Red, Device Series HDSP-A10x/E10x/H10x/K12x/N10x/F10x						
Luminous Intensity/Segment (Digital Average) ^{a, b}	I_V				mcd	$I_F = 1 \text{ mA}$
HDSP-A10x		0.315	0.900	—		
HDSP-F10x		0.330	1.200	—		
HDSP-E10x		0.390	1.100	—		
HDSP-H10x, HDSP-K12x HDSP-N10x		0.400 0.270	1.150 1.100	— —		
Forward Voltage/Segment or DP ^c	V_F	—	2.1	2.5	V	$I_F = 20 \text{ mA}$
Peak Wavelength	λ_p	—	656	—	nm	
Dominant Wavelength ^d	λ_d	—	639	—	nm	
Reverse Voltage/Segment or DP ^e	V_R	3.0	—	—	V	$I_R = 100 \mu\text{A}$
Red, Device Series HDSP-751x/335x/555x						
Luminous Intensity/Segment (Digital Average) ^{a, b}	I_V				mcd	$I_F = 2 \text{ mA}$
HDSP-751x		0.315	1.800	—		
HDSP-335x HDSP-555x		0.391 0.415	2.000 2.200	— —		
Forward Voltage/Segment or DP ^c	V_F	—	2.05	2.5	V	$I_F = 20 \text{ mA}$
Peak Wavelength	λ_p	—	631	—	nm	
Dominant Wavelength ^d	λ_d	—	622	—	nm	
Reverse Voltage/Segment or DP ^e	V_R	3.0	—	—	V	$I_R = 100 \mu\text{A}$

Parameter	Symbol	Min.	Typ.	Max.	Unit	Test Conditions
Yellow, Device Series HDSP-A80x						
Luminous Intensity/Segment (Digital Average) ^{a, b}	I_V	0.625	2.60	—	mcd	$I_F = 4 \text{ mA}$
Forward Voltage/Segment or DP ^c	V_F	—	2.0	2.5	V	$I_F = 20 \text{ mA}$
Peak Wavelength	λ_p	—	591	—	nm	
Dominant Wavelength ^d	λ_d	581.5	588	592.5	nm	
Reverse Voltage/Segment or DP ^e	V_R	3.0	—	—	V	$I_R = 100 \mu\text{A}$
High Performance Green, Device Series HDSP-A90x						
Luminous Intensity/Segment (Digital Average) ^{a, b}	I_V	0.425	2.60	—	mcd	$I_F = 4 \text{ mA}$
Forward Voltage/Segment or DP ^c	V_F	—	2.1	2.5	V	$I_F = 20 \text{ mA}$
Peak Wavelength	λ_p	—	572	—	nm	
Dominant Wavelength ^d	λ_d	—	571	577	nm	
Reverse Voltage/Segment or DP ^e	V_R	3.0	—	—	V	$I_R = 100 \mu\text{A}$

- a. The luminous intensity, I_V , is measured at the mechanical axis of the package.
- b. The optical axis is closely aligned with the mechanical axis of the package.
- c. Forward voltage tolerance is $\pm 0.1\text{V}$.
- d. The dominant wavelength, λ_d , is derived from the CIE Chromaticity Diagram and represents the color of the device.
- e. Typical specification for reference only. Do not exceed absolute maximum ratings, and long-term reverse bias is not recommended.

Part Numbering System

5082 - X XX X - X X X XX
HDSP - X XX X - X X X XX

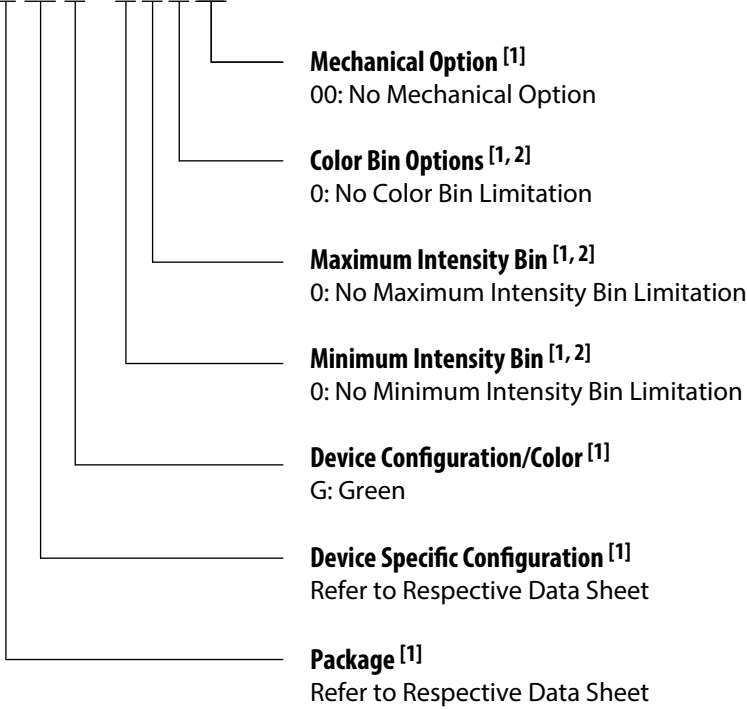

1. For codes not listed in the figure, refer to the respective data sheet or contact your nearest Broadcom representative for details.
2. Bin options refer to shippable bins for a part number. Color and Intensity Bins are typically restricted to 1 bin per tube (exceptions may apply). Refer to respective data sheet for specific bin limit information.

Intensity Bin Limits (mcd)

Deep Red

Table 1: HDSP-A10x Series

IV Bin Category	Min.	Max.
E	0.315	0.520
F	0.428	0.759
G	0.621	1.16
H	0.945	1.71
I	1.40	2.56
J	2.10	3.84
K	3.14	5.75
L	4.70	8.55

Table 2: HDSP-E10x/HDSP-F10x Series

IV Bin Category	Min.	Max.
D	0.391	0.650
E	0.532	0.923
F	0.755	1.39
G	1.13	2.08
H	1.70	3.14

Table 3: HDSP-H10x/HDSP-K12x Series

IV Bin Category	Min.	Max.
C	0.415	0.690
D	0.565	0.990
E	0.810	1.50
F	1.20	2.20
G	1.80	3.30
H	2.73	5.00
I	4.09	7.50

Table 4: HDSP-N10x Series

IV Bin Category	Min.	Max.
A	0.270	0.400
B	0.325	0.500
C	0.415	0.690
D	0.565	0.990
E	0.810	1.50
F	1.20	2.20
G	1.80	3.30
H	2.73	5.00
I	4.09	7.50

Red

Table 5: HDSP-751x Series

IV Bin Category	Min.	Max.
E	0.315	0.520
F	0.428	0.759
G	0.621	1.16
H	0.95	1.75
I	1.43	2.64
J	2.16	3.97

Table 6: HDSP-335x Series

IV Bin Category	Min.	Max.
D	0.391	0.650
E	0.532	0.923
F	0.755	1.39
G	1.13	2.08
H	1.70	3.14
I	2.57	4.70

Table 7: HDSP-555x

IV Bin Category	Min.	Max.
C	0.415	0.690
D	0.565	0.990
E	0.810	1.50
F	1.20	2.20
G	1.80	3.30
H	2.73	5.00
I	4.09	7.50

Yellow

Table 8: HDSP-A80x

IV Bin Category	Min.	Max.
D	0.250	0.385
E	0.315	0.520
F	0.425	0.760
G	0.625	1.14
H	0.940	1.70
I	1.40	2.56
J	2.10	3.84
K	3.14	5.76
L	4.71	8.64
M	7.07	13.00
N	10.60	19.40
O	15.90	29.20
P	23.90	43.80
Q	35.80	65.60

Color Categories

Color	Bin	Dominant Wavelength (nm)	
		Min.	Max.
Yellow	1	581.50	585.00
	3	584.00	587.50
	2	586.50	590.00
	4	589.00	592.50
Green	2	573.00	577.00
	3	570.00	574.00
	4	567.00	571.00
	5	564.00	568.00

NOTE: All categories are established for classification of products. Products may not be available in all categories. Contact your Broadcom representatives for further clarification or information.

Green

Table 9: HDSP-A90x

IV Bin Category	Min.	Max.
E	0.315	0.520
F	0.425	0.760
G	0.625	1.14
H	0.940	1.70
I	1.40	2.56
J	2.10	3.84
K	3.14	5.76
L	4.71	8.64
M	7.07	13.00
N	10.60	19.40
O	15.90	29.20
P	23.90	43.80
Q	35.80	65.60

Deep Red Graphs

Figure 9: Relative Intensity vs. Wavelength

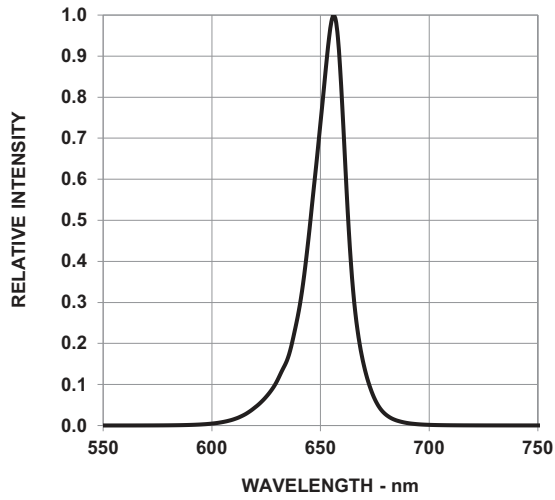

Figure 10: Forward Current vs. Forward Voltage

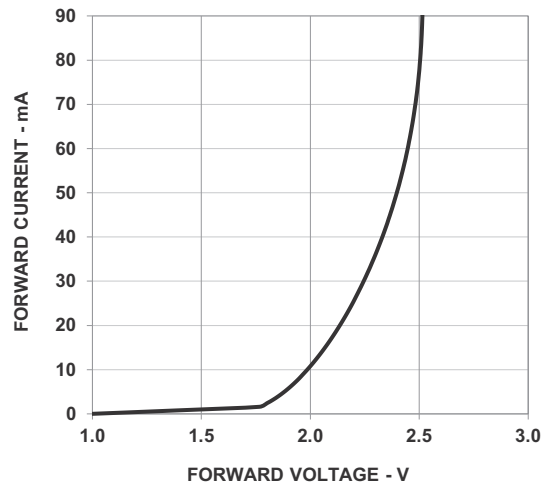

Figure 11: Relative Luminous Intensity vs. Forward Current

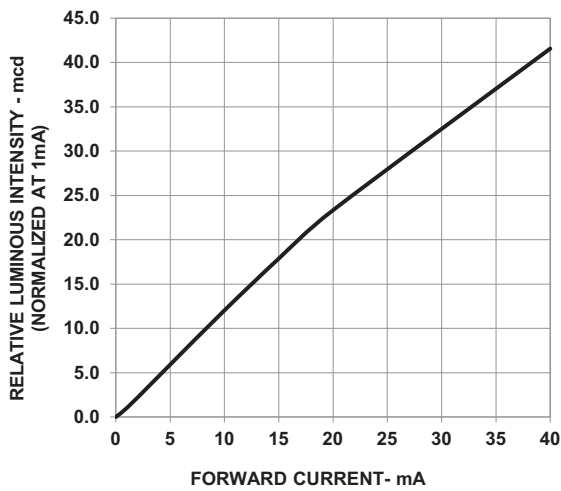
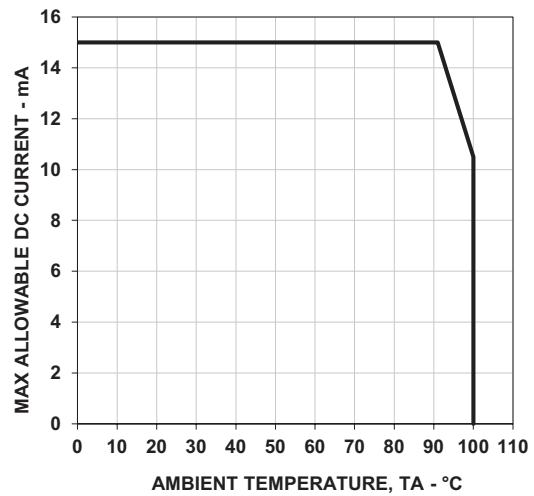

Figure 12: Maximum Forward Current vs. Ambient Temperature



Red Graphs

Figure 13: Relative Intensity vs. Wavelength

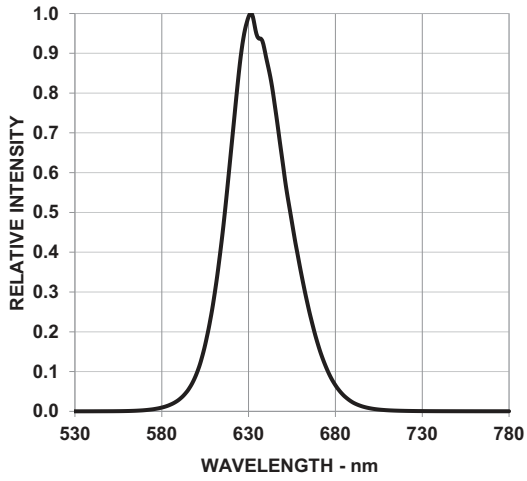

Figure 14: Forward Current vs. Forward Voltage

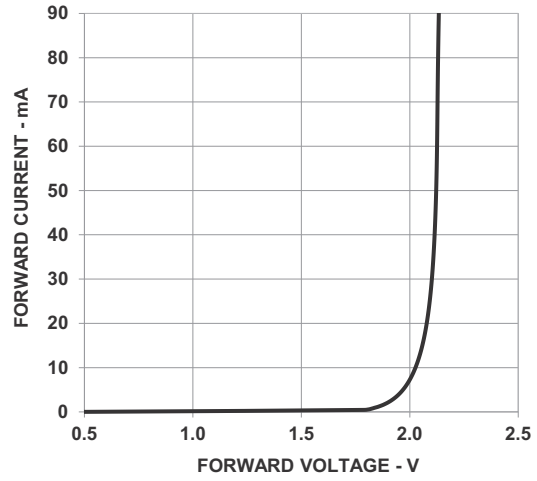

Figure 15: Relative Luminous Intensity vs. Forward Current

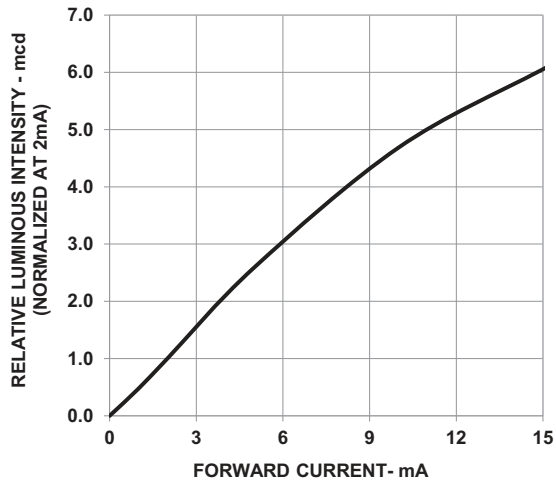
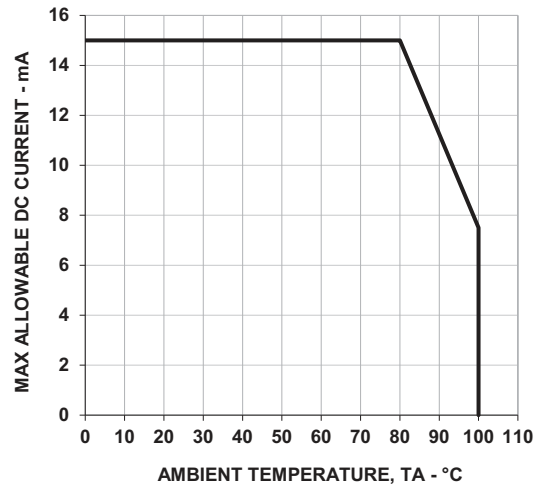

Figure 16: Maximum Forward Current vs. Ambient Temperature



Green Graphs

Figure 17: Relative Intensity vs. Wavelength

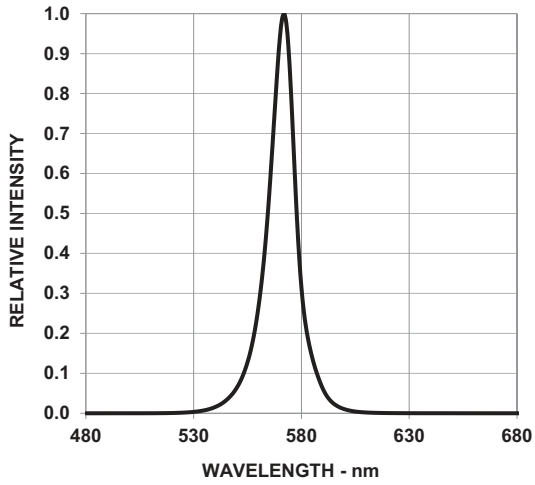

Figure 18: Forward Current vs. Forward Voltage

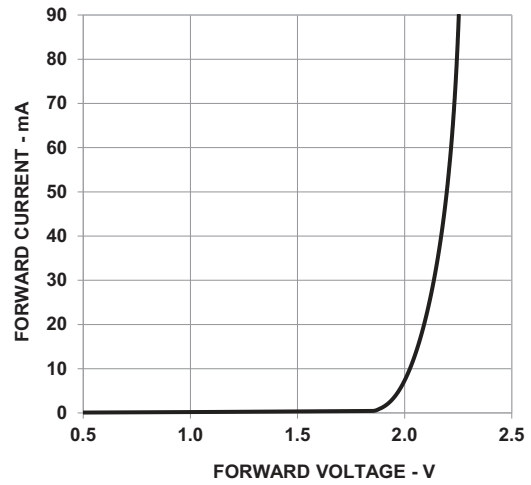

Figure 19: Relative Luminous Intensity vs. Forward Current

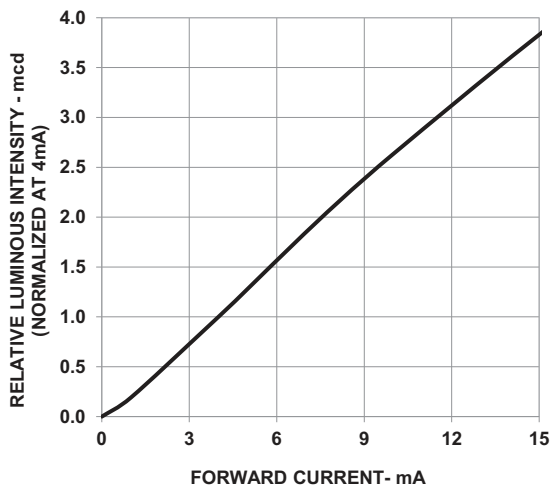
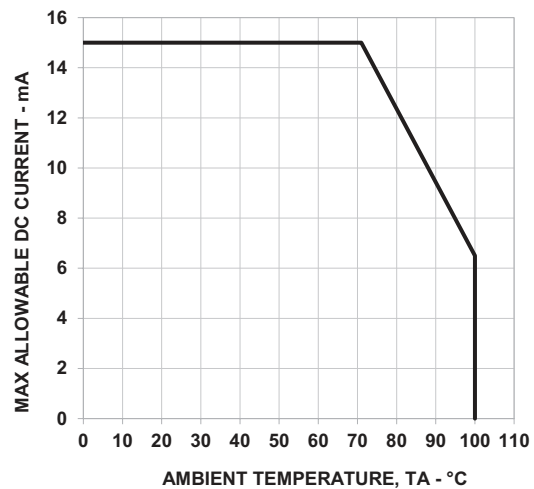

Figure 20: Maximum Forward Current vs. Ambient Temperature



Yellow Graphs

Figure 21: Relative Intensity vs. Wavelength

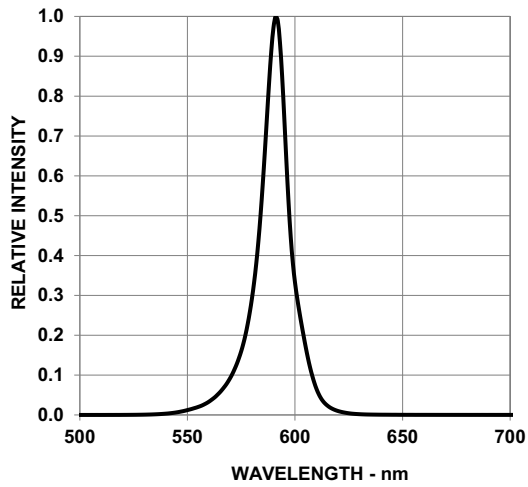

Figure 22: Forward Current vs. Forward Voltage

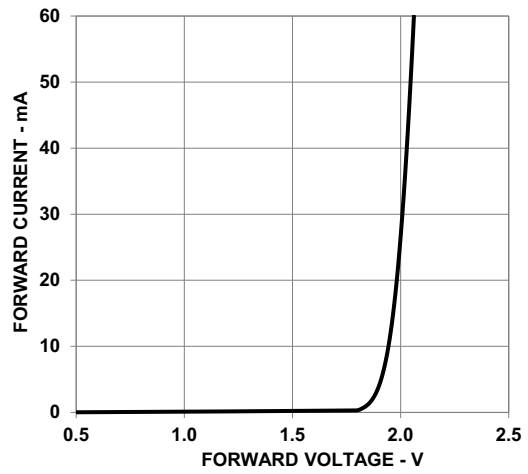

Figure 23: Relative Luminous Intensity vs. Forward Current

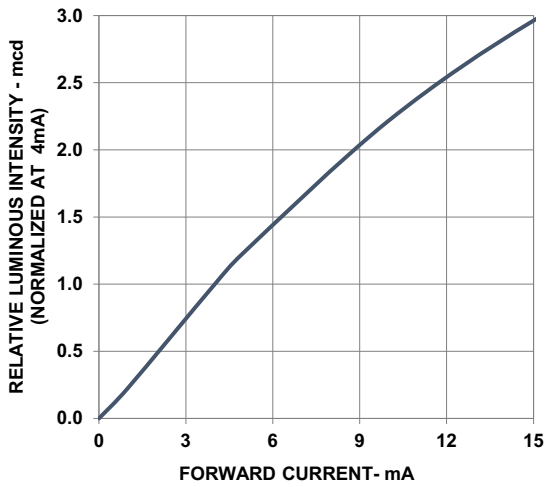
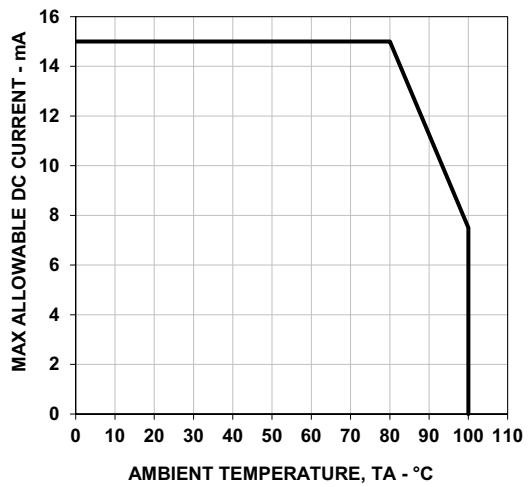

Figure 24: Maximum Forward Current vs. Ambient Temperature



Precautionary Notes

Soldering and Handling Precautions

- Set and maintain the wave soldering parameters according to the recommended temperature and dwell time. Perform daily checks on the profile to ensure that it is always conforming to the recommended conditions. Exceeding these conditions will over-stress the LEDs and cause premature failures.
- Use only bottom preheaters to reduce thermal stress experienced by the LEDs.
- Recalibrate the soldering profile before loading a new type of a PCB. PCBs with different sizes and designs (component density) will have different heat capacities and might cause a change in temperature experienced by the PCB if the same wave soldering setting is used.
- Do not perform wave soldering more than once.
- Any alignment fixture used during wave soldering must be loosely fitted and must not apply stress on the LEDs. Use non-metal material because it will absorb less heat during the wave soldering process.
- At elevated temperatures, the LEDs are more susceptible to mechanical stress. Allow the PCB to be sufficiently cooled to room temperature before handling. Do not apply stress to the LED when it is hot.
- Use wave soldering to solder the LED. Use hand soldering only for rework or touch up if unavoidable, but it must be strictly controlled to following conditions:
 - Soldering iron tip temperature = 315°C maximum.
 - Soldering duration = 2 seconds maximum.
 - Number of cycles = 1 only.
 - Power of soldering iron = 50W maximum.
- For ESD-sensitive devices, apply proper ESD precautions at the soldering station. Use only an ESD-safe soldering iron.
- Do not touch the LED package body with the soldering iron except for the soldering terminals because it may cause damage to the LED.
- Confirm beforehand whether the functionality and performance of the LED is affected by soldering with hand soldering.
- Keep the heat source at least 1.6 mm away from the LED body during soldering.
- Design an appropriate hole size to avoid problems during insertion.
- Cleaning agents from the ketone family (acetone, methyl ethylketone, and so on) and from the chlorinated hydrocarbon family (methylene chloride,

trichloroethylene, carbon tetrachloride, and so on) are not recommended for cleaning the LED displays. All of these various solvents attack or dissolve the encapsulating epoxies used to form the package of plastic LED parts.

- For the purpose of cleaning, wash with DI water only. The cleaning process should take place at room temperature only. Clear any water or moisture from the LED display immediately after washing.
- Use of *No clean* solder paste is recommended for soldering.

Figure 25: Recommended Wave Soldering Profile

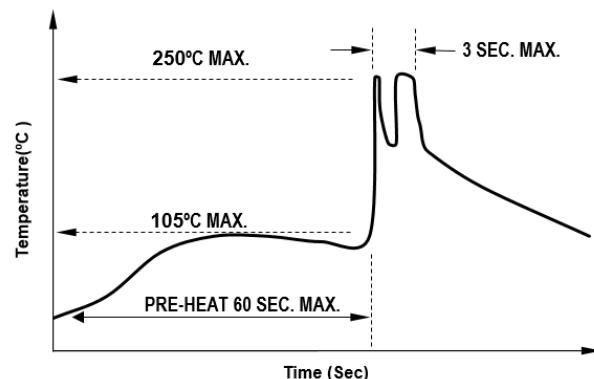

NOTE: Figure 25 refers to measurements with thermocouple mounted at the bottom of the PCB.

Application Precautions

- The drive current of the LED must not exceed the maximum allowable limit across temperatures as stated in the data sheet. Constant current driving is recommended to ensure consistent performance.
- Circuit design must cater to the whole range of forward voltage (V_F) of the LEDs to ensure the intended drive current can always be achieved.
- The LED exhibits slightly different characteristics at different drive currents, which may result in a larger variation of performance (such as intensity, wavelength, and forward voltage). Set the application current as close as possible to the test current to minimize these variations.
- The LED is not intended for reverse bias. Use other appropriate components for such purposes. When driving the LED in matrix form, ensure that the reverse bias voltage does not exceed the allowable limit of the LED.

- Avoid rapid change in ambient temperatures, especially in high-humidity environments, because they cause condensation on the LED.
- If the LED is intended to be used in a harsh or outdoor environment, protect the LED against damages caused by rain, water, dust, oil, corrosive gases, external mechanical stresses, and so on.

Eye Safety Precautions

LEDs may pose optical hazards when in operation. Do not look directly at operating LEDs because it might be harmful to the eyes. For safety reasons, use appropriate shielding or personal protective equipment.

Disclaimer

Broadcom's products and software are not specifically designed, manufactured, or authorized for sale as parts, components, or assemblies for the planning, construction, maintenance, or direct operation of a nuclear facility or for use in medical devices or applications. The customer is solely responsible, and waives all rights to make claims against Broadcom or its suppliers, for all loss, damage, expense, or liability in connection with such use.

Copyright © 2005–2022 Broadcom. All Rights Reserved. The term “Broadcom” refers to Broadcom Inc. and/or its subsidiaries. For more information, go to www.broadcom.com. All trademarks, trade names, service marks, and logos referenced herein belong to their respective companies.

Broadcom reserves the right to make changes without further notice to any products or data herein to improve reliability, function, or design. Information furnished by Broadcom is believed to be accurate and reliable. However, Broadcom does not assume any liability arising out of the application or use of this information, nor the application or use of any product or circuit described herein, neither does it convey any license under its patent rights nor the rights of others.

