



Copyright FCI

B

C

D

TECHNICAL SPECIFICATION

- Insulation Resistance - 500 M Ohms min.
- Dielectric Strength - 1000 V rms , 60 Hz.
- Contact Resistance - 20 milli,Ohms. max.
- Current Rating - 1.5 amp DC
- Maximum Total Mating Force - 35 N
- Retention Force Between Plug & Jack - 22.5 N min.
- Durability - 500 mating cycles
- Temperature Range -25 / + 90 Deg C.

Material:

Housing : PBT 30% Glass Filled UL 94 V-0 Black

The housing will withstand exposure to 260-265°C for 3.5 seconds in a wassoldering application. Use protective adhesive tape(Kapton or Teflon) or protective metallic devices on the areas which are directly exposed to wave soldering as it is used in classical leaded wave soldering.

Contact : Ø0.46mm Phosphor Bronze

Plating :

Active zone : Gold over nickel on contact area

Termination zone : SnPb over Nickel (Leaded vesion)

: Matte Tin over nickel (Lead Free version)

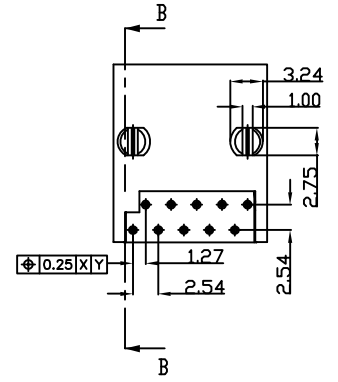
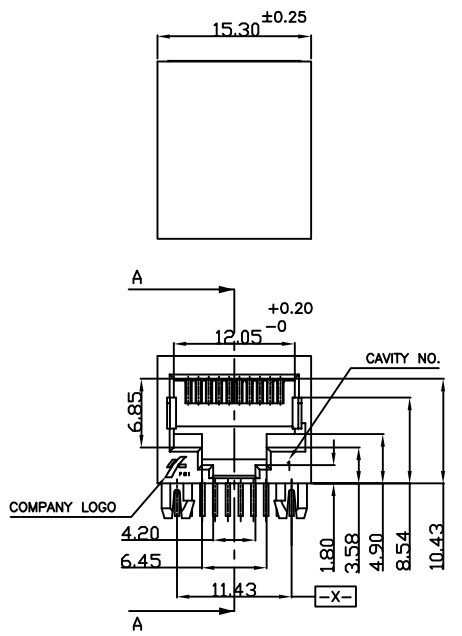
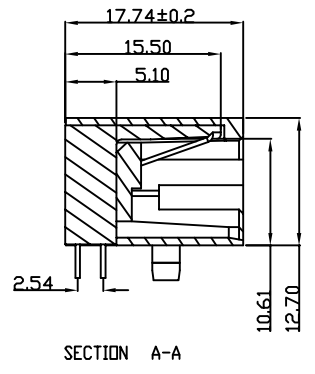

- 1.LF Products meet European Union Directives and other country Regulations as described in GS-22-008.
- 2.The Housing will withstand exposure to 260° peak temperature for 3.5 sec in a wave solder application with a 1.6mm Min thick circuit board. Slight deformation of snap pegs may occur at 260-265°c which will not affect the function of the product.
- 3.Lead Free or ROHS Directive labelling to be provided as per GS-14-920 for Lead Free version.

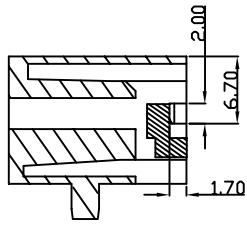
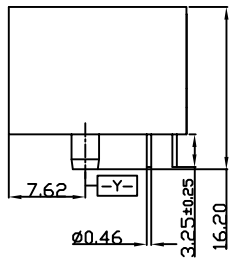

SECTION B-B

NOTES:

1. ALL WIRES MUST BE STRAIGHT TO THE SHELF

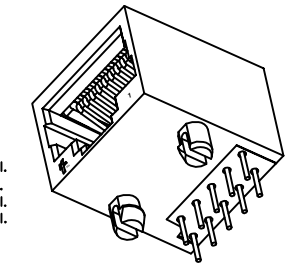
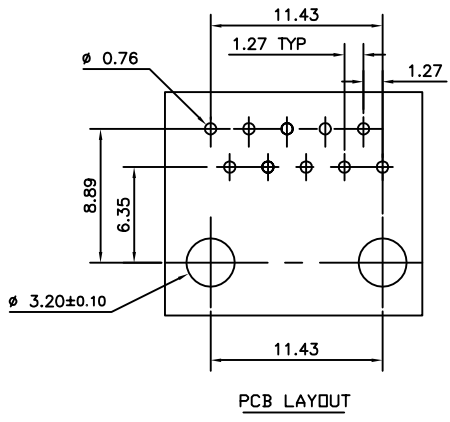

PART NO. 54602-X10 LF
LEAD FREE
6-0.76 µ Au.Sel.
7-Au Flash.Sel.
8-1.27 µ Au.Sel.
9-0.38 µ Au.Sel.

mat'l. code		surface		tolerance		projection		product family	
-		ISO 1302		ISO 406 ISO 1101		MM		MODJACK	
ltr	ecn no	dr	date	tolerances unless otherwise specified		MM		title	
D	106-0123	HVN	2006-07-21	±0.1		MM		10 POL SHALLOW LATCH CONNECTOR	
E	107-0039	HVN	2007-03-16	angles	linear	MM		(PCB.MODJACK)	
F	107-0122	HVN	2007-09-19	±1°		scale		-	
dr		MINI K VANDANATH		2003-04-04		FCI		dwg no	
enr		HIRANV.N		2003-04-04		FCI		sheet 1 of 1	
chr		HIRANV.N		2007-09-19		FCI		size	
appd		HIRANV.N		2007-09-19		FCI		A3	
sheet		revision		F		type		Product Customer Drawing	
index		sheet		1		type		Product Customer Drawing	