



# East Electronics



## Product Specification

48273 Lakeview Blvd  
 Fremont, CA 94538, U.S.A  
 Tel: 510-413-0002  
 Fax: 510-413-0010  
<http://www.east-elec.com>

<b>Product Name:</b>	Pi ezo Buzzer
<b>Part Number :</b>	EFM 620LA
<b>Ver si on:</b>	1. 02
<b>Dat e:</b>	2017/ 10/ 10
<b>Not e:</b>	

**Company passed ISO 9001 / ISO TS16949 / ISO 14001Certifications**

### Revision History

Rev.	Description	Author/Date	Checked By	Approver
1.02	Change the company name to East Electronics	SYSTEM 2017-10-10		
1.01	Quality Certificate Symbol revised	吕文斌 2015-2-9	汤礼东	王建成
1.0	Released	汤礼东 2011-12-21	张春雷	王建成

## 1. Part Number EFM-620LA

## 2. Dimension Drawing (Unit: mm)

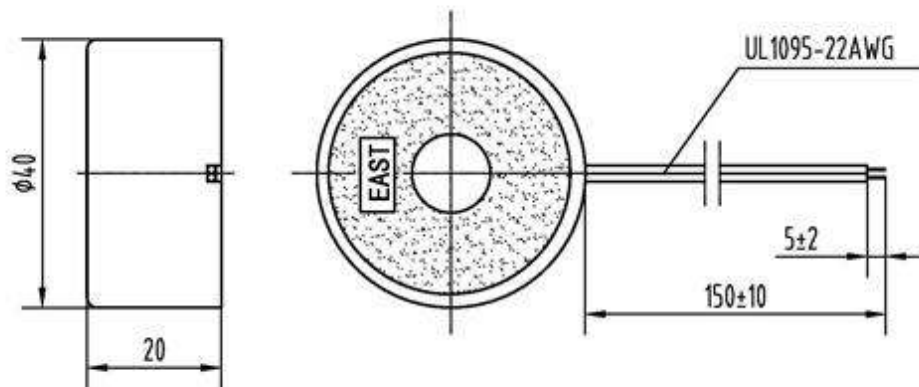

## 3. Specification

No.	Item	Specification
3-1	Min. Sound Pressure Level	90dB/9V <sub>DC</sub> /100cm
	*Min. Sound Pressure Level	100dB/9V <sub>DC</sub> /100cm
3-2	Rated Voltage	9V <sub>DC</sub>
3-3	Max. Consumption	50mA/9V <sub>DC</sub>
3-4	Oscillating Frequency	2.8±0.5 kHz
3-5	Tone Nature	Continuous
3-6	Operating Temperature	-20~+60°C
3-7	Case Material/Color	ABS/Black
3-8	Weight	12.5g
3-9	Wire Standard	UL1095-22AWG

### NOTES:

- \*The sound pressure could reach 100dB(A) if our buzzer were put into your housing.
- Test should be made under the conditions of room temperature (20±10°C), normal humidity (60±20%) and normal atmospheric pressure. In this case, however, that the judgment is questionable, the test conditions are to be changed to room temperature 20±2°C, relative humidity 60~70% and normal atmospheric pressure

#### 4. Typical Frequency Response Curve

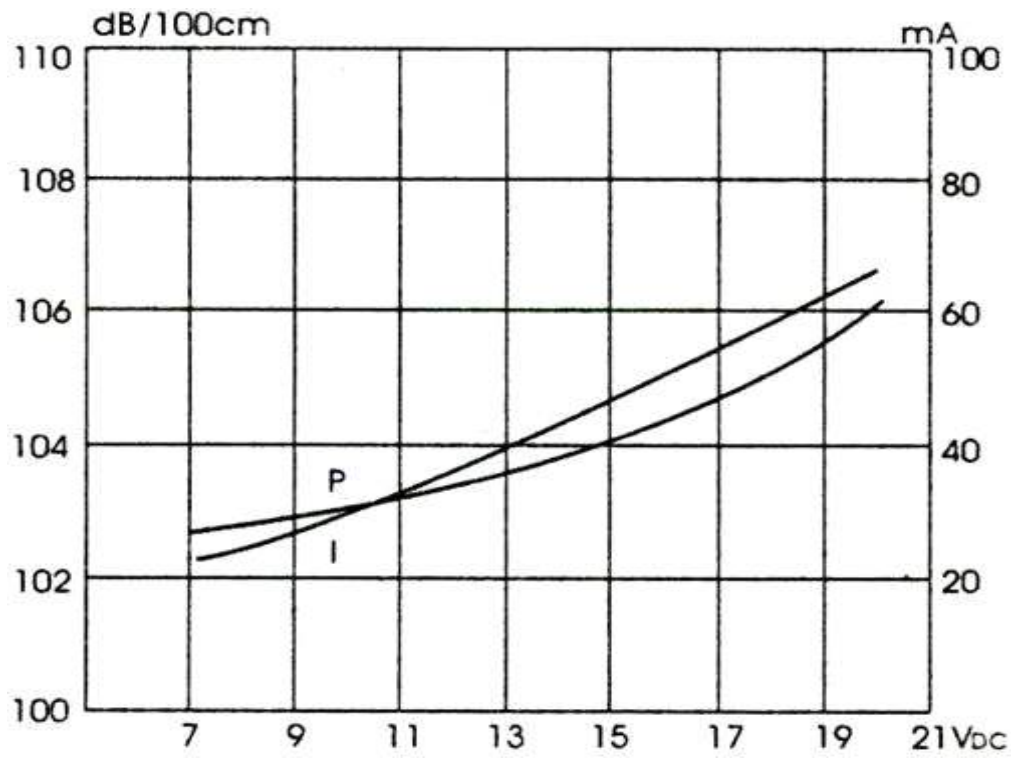

**Note:**Distance 100 cm

## 5. Reliability Test

No.	Item	Method of Test	Tolerance after Testing
5-1	Operating Temperature	-20~+60°C	Sound pressure level initial value $\pm 10\text{dB}$  Max. consumption value $\pm 20\%$  Oscillating Frequency value $\pm 20\%$
5-2	Storage in high temperature	Storage in +60°C test box 96 hours then exposed to the room temperature for 2 hours	
5-3	Storage in low temperature	Storage in -20°C test box 96 hours then exposed to the room temperature for 2 hours	
5-4	Life test in the room temperature	Operate the product continuously 5 seconds on 5 seconds off 300 hours at rated voltage	
5-5	Temperature / humidity cycle test	Storage in +40°C, 93 $\pm$ 3%RH test box 96 hours then exposed to the room temperature for 2 hours	
5-6	Temperature (high and low) cycle test	Conduct the test for 5 cycles without applying power then expose to the room temperature for 2 hours.(See Figure 5-6)	
5-7	Vibration test	Conduct the test for the directions of X Y and Z for 0.5 hour each (total 1.5 hours). To-and Fri sweep time(from 10 to 55Hz and then 55 to 10) under single amplitude of 0.75mm is 3 minute, then expose to the room temperature for 2 hours	
5-8	Drop test	Drop a product naturally from the height of 700mm onto the surface of 100mm thick wooden board. Two directions: upper and side of the product are to be applied for this drop test once respectively	

Figure 5-6

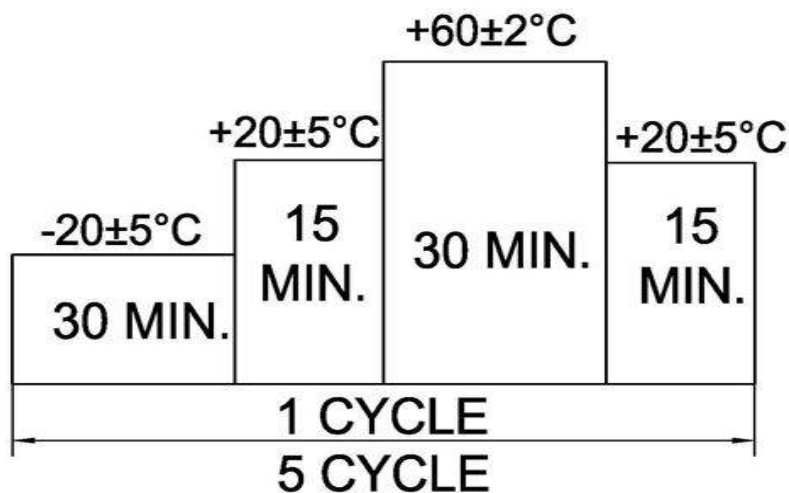

## 6. Electrical Testing Method

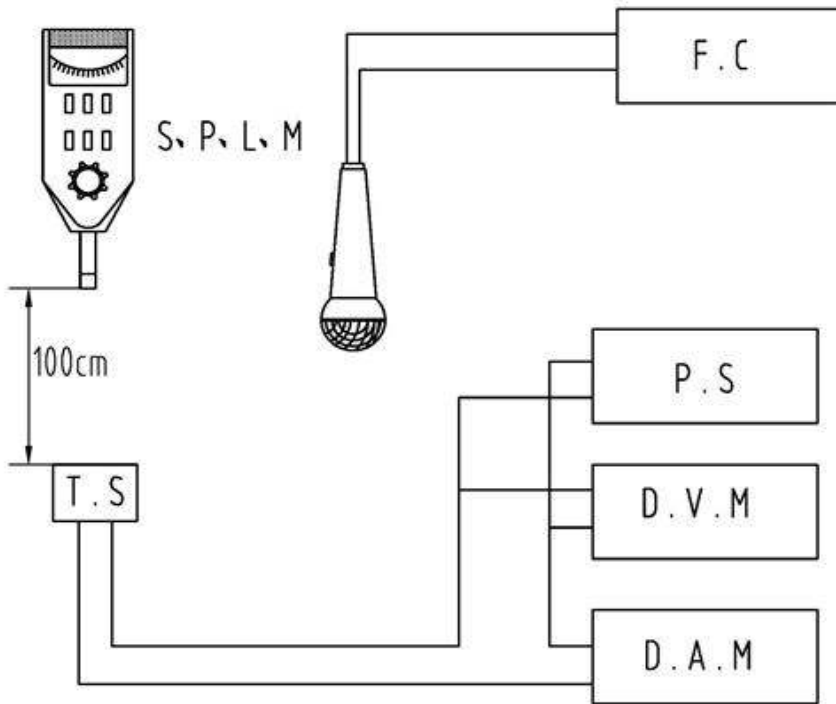

S.P.L.M	Sound Pressure Level Meter
T.S	Testing Sample
F.C	Frequency Counter
P.S	Power Supply
D.V.M	DC Voltage Meter
D.A.M	DC Ampere Meter

## 7. Packing Information

**Packing: 800 pcs per export carton**

**Carton Size: 47× 30.5× 29 cm**

**G. Weight: 12.8 kgs N. Weight: 10.0 kgs**