

DIESES ZEICHNUNGSDOKUMENT WIRD DURCH AMP INCORPORATED KONTROLLIERT. AENDERUNGEN, DIE DEM TECHNISCHEN FORTSCHRITT DIENEN, SIND VORBEHALTEN. DEN JEWEILS LETZTGUELTIGEN AENDERUNGSSTAND ERFAHREN SIE AUF ANFRAGE.

MATED WITH: PASSEND ZU:	LOC A1	DIST -	REVISIONS AENDERUNGEN					
PROJEKT NR.:			P	LTR	DESCRIPTION BESCHREIBUNG	DATE	DWN	APVD
				A	NEW DRAWING	16OCT2013	SMD	DWE
				A1	DRAWING MADE ACTIVE	05FEB2015	VA	FW I
				A2	SUPERSEDED STANDARD EXCHANGED	13MAR215	VA	FW I

NOTES:

Bemerkungen:

- 1 SCREW FOR PLASTIC
Schraube fuer Kunststoff
- 2 COUNTERSUNK SCREW
Senkkopfschraube
- 3 DRIVE I-ASTERISK T10 (0,9-1,2mm DEEP)
Antrieb I-Stern T10 (0,9-1,2mm tief)
- 4 NOT SPECIFIED TOLERANCES ACC. TO ISO 2768-mK
Allgemeintoleranz nach

A2

A-A

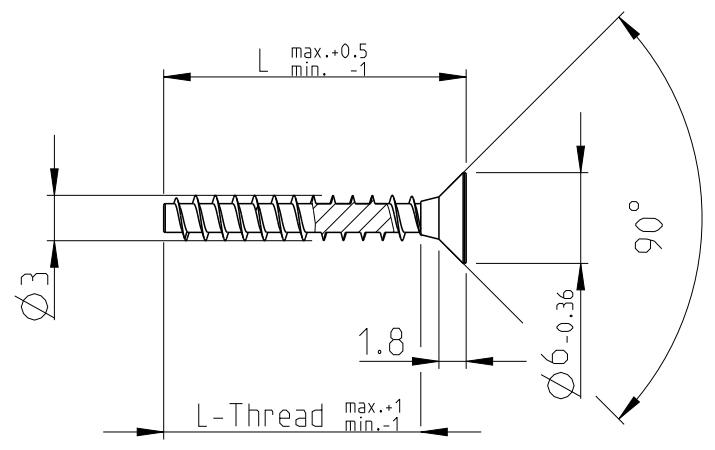
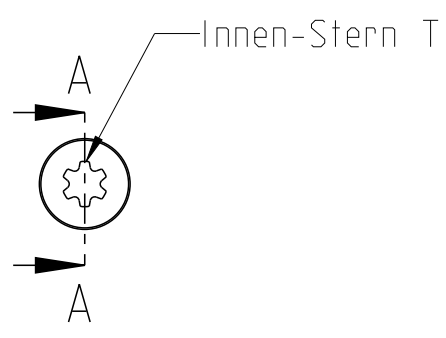

1-1241473-4	A	20	16	17MnB4	Zn-Ni passiviert min 5µ + Versiegelung Fe// Zn Ni 5 // Fn // T2 DIN 50979	BLACK
PART NO	REV	L [mm]	L-Thread [mm]	MATERIAL	FINISH	COLOR

2011 -
 RELEASED FOR PUBLICATION
 FREI FUER VEROFFENTLICHUNG
 ALL RIGHTS RESERVED.
 ALLE INTERNATIONALEN RECHTE VORBEHALTEN.
 THIS DRAWING IS UNPUBLISHED.
 VERTRAULICHE UNVEROFFENTLICHTE ZEICHNUNG
 COPYRIGHT 2011

DIMENSIONS: MASSEINHEITEN: MM	DWN	160CT2013	MATERIAL	Base/Grundlage DIN EN 10263-4	FINISH	OBERFLAECHE/FARBE	-								
	Sundareshan M D	160CT2013	CHK	F. Wittrock	160CT2013	TE Connectivity									
TOLERANCES UNLESS OTHERWISE SPECIFIED: ALLGEMEINTOLERANZEN	APVD	160CT2013	PRODUCT SPEC	PRODUKTSPEZ.	NAME SELF TAPPING SCREW Kunststoffschraube										
	D. Weyrauch	160CT2013	APPLICATION SPEC	VERARBEITUNGSSPEZ.				SIZE	CAGE CODE	DRAWING NO ZEICHNUNGS-NR.	RESTRICTED TO NUR FUER				
0 PLC ±-	1 PLC ±-	2 PLC ±-	3 PLC ±-	4 PLC ±-	ANGLES /W INKEL	±1°	A 4	00779	C= 1241473	-					
WEIGHT GEWICHT		-		Customer Drawing		/KUNDENZEICHNUNG		SCALE MASSSTAB	2:1	SHEET BLATT	1	OF VON	1	REV	A2