

REVISIONS					
P	LTR	DESCRIPTION	DATE	DWN	APVD
	N3	REVISED PER ECN-22-150900	28APR2022	RK	CSD

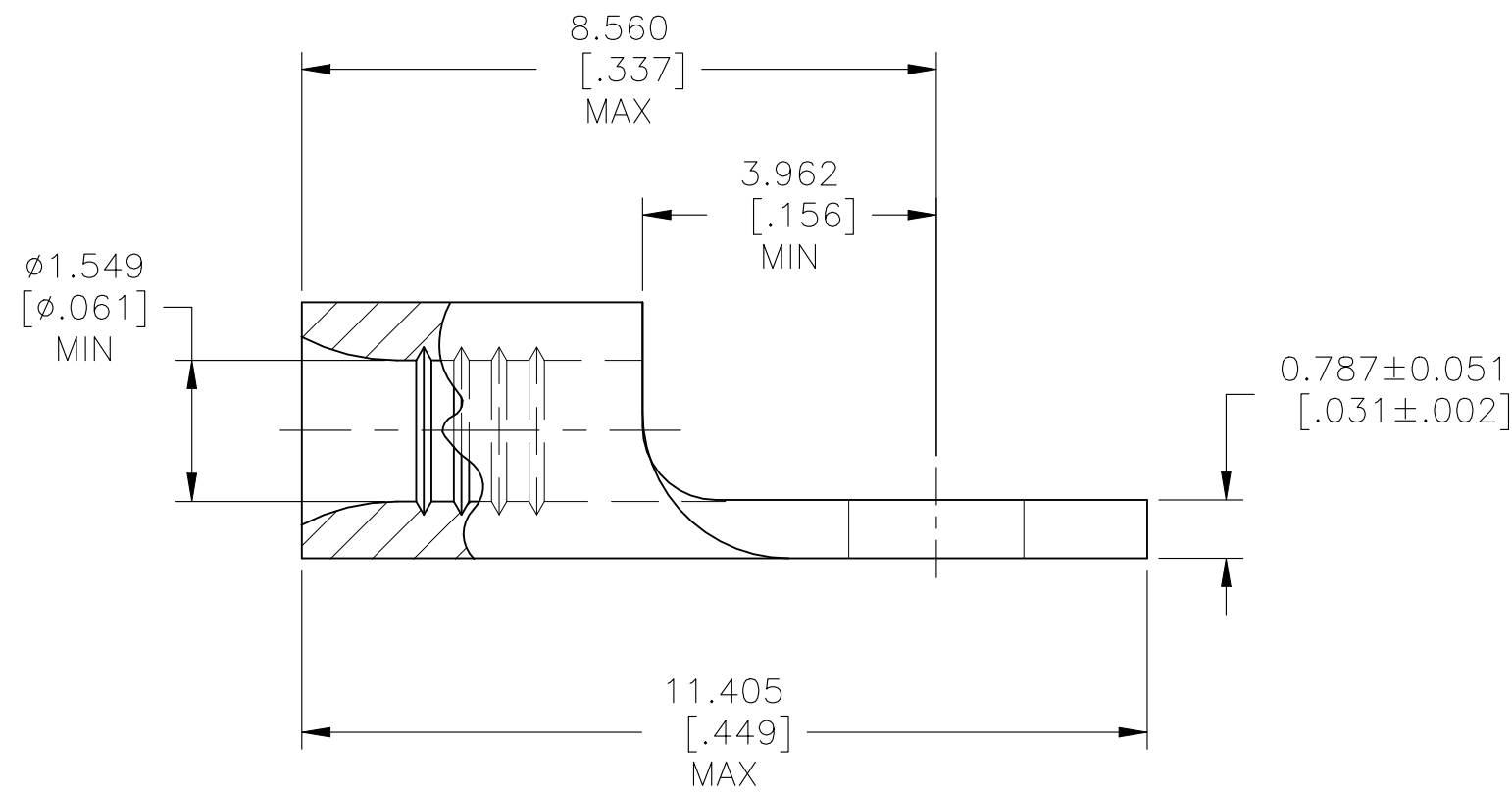
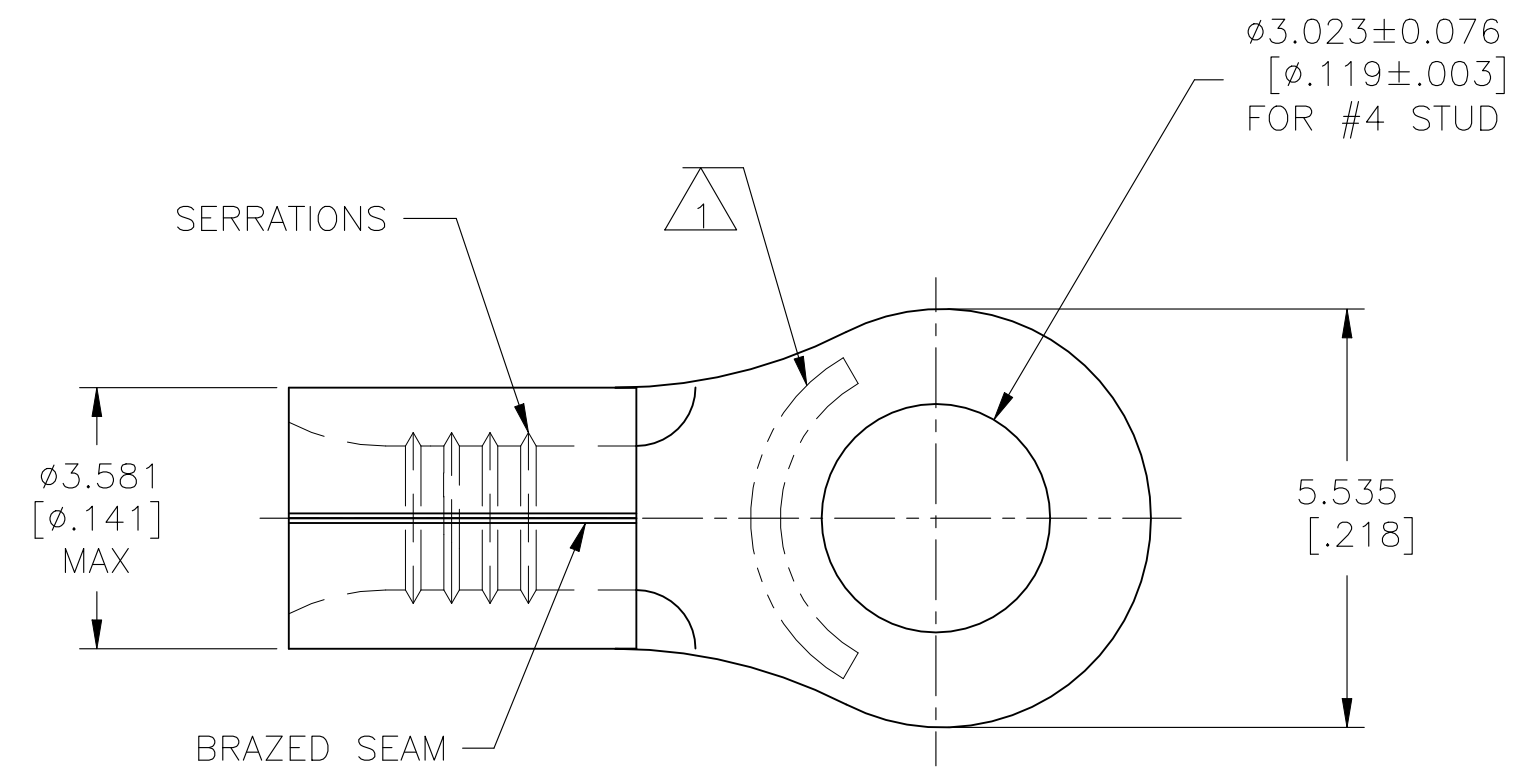
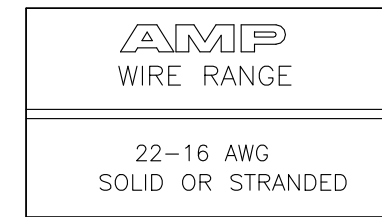

- 1 STAMP AMP 22-18* APPROX AS SHOWN 22-16 TERMINALS ARE STAMPED 22-18 IN ACCORDANCE WITH MILITARY SPECIFICATION SAE AS7928; COMMERCIAL WIRE RANGE IS 22-16
- 2 TIN PLATE 0.00254 [0.000100] MIN EXT THK PER ASTM-B-545.
- 3 TIN LEAD PLATE 0.01016-0.02032[0.000400-.000800] MIN EXT THK PER MIL-P-81728
- 4 GOLD PLATE, 0.00254[0.000100] MIN EXT THK PER ASTM B488 TYPE 1, CODE C OVER NICKEL PLATE 0.00127[0.000050] MIN EXT THK PER SAE AMS QQ-N-290. OVER Cu FLASH PER SAE AMS 2418.
- 5 NOTE DELETED
- 6 .000300 MIN EXT THK NICKEL PER SAE AMS QQ-N-290
- 7 COPPER PER ASTM B-152, ANNEALED
- 8 UL LISTED E13288, 22-16 AWG SOLID OR STRANDED.
- 9 CSA CERTIFIED LR7189, 22-16 AWG SOLID OR STRANDED
- 10 NOTE DELETED
- 11 NOTE DELETED
- 12 NOTE DELETED
- 13 UL 486 A-B

△△	170°C[338°F]	△	100	LOOSE PIECE, BOX	8-34104-1
△△	170°C[338°F]	△	5000	34104 ON TAPE	2-34104-6
	343°C[649°F]	△	1000	LOOSE PIECE	34104-6
	260°C[500°F]	△	1000	LOOSE PIECE	34104-4
△△	170°C[338°F]	△	1000	LOOSE PIECE	34104-2
△△	170°C[338°F]	△	1000	LOOSE PIECE	34104
	MAX TEMP	FINISH	QTY	PACKAGE TYPE	PART NO.

AMP INCORPORATED CUSTOMER SERVICE SYSTEMS		MAX RECOMMENDED OPERATING TEMPERATURE: SEE TABLE
FOR ADDITIONAL PRODUCT INFORMATION OR COPIES OF DRAWINGS AND TECHNICAL DOCUMENTS	PRODUCT INFORMATION CENTER 1-800-522-6752	VOLTAGE RATING: N/A
FOR APPLICATION TOOLING INFORMATION	TOOLING ASSISTANCE CENTER 1-800-722-1111	CIRCULAR MIL AREA: 0.26-1.65mm ² [509-3260] SOLID OR STRANDED
FOR ORDER ENTRY	1-800-526-5142	THIS DRAWING IS A CONTROLLED DOCUMENT FOR AMP INCORPORATED. IT IS SUBJECT TO CHANGE AND THE CONTROLLING ENGINEERING ORGANIZATION SHOULD BE CONTACTED FOR THE LATEST REVISION.

THIS DRAWING IS A CONTROLLED DOCUMENT.		DWN TA BRINKMAN 3-10-93			
DIMENSIONS: mm [INCHES]		CHK DA PATTERSON 3-10-93			
TOLERANCES UNLESS OTHERWISE SPECIFIED:		APVD JL MECKLEY 3-10-93	NAME		
0 PLC ± - 1 PLC ± - 2 PLC ± - 3 PLC ± 0.127[0.005] 4 PLC ± - ANGLES ± -		PRODUCT SPEC △	TERMINAL, RING TONGUE, SOLISTRAND, WIRE SIZE: 22-16 AWG		
MATERIAL △		FINISH SEE TABLE	SIZE A2	CAGE CODE 00779	DRAWING NO C=34104
		WEIGHT -	RESTRICTED TO	SCALE 10:1	SHEET 1 of 1
		CUSTOMER DRAWING	REV N3		