

THIS DRAWING IS UNPUBLISHED. RELEASED FOR PUBLICATION
 © COPYRIGHT BY TYCO ELECTRONICS CORPORATION. ALL RIGHTS RESERVED.

LOC	DIST	REVISIONS			
P	LTR	DESCRIPTION	DATE	DWN	APVD
		D1	ADDED -4 PER ECR-07-026893	08NOV07	MF GP

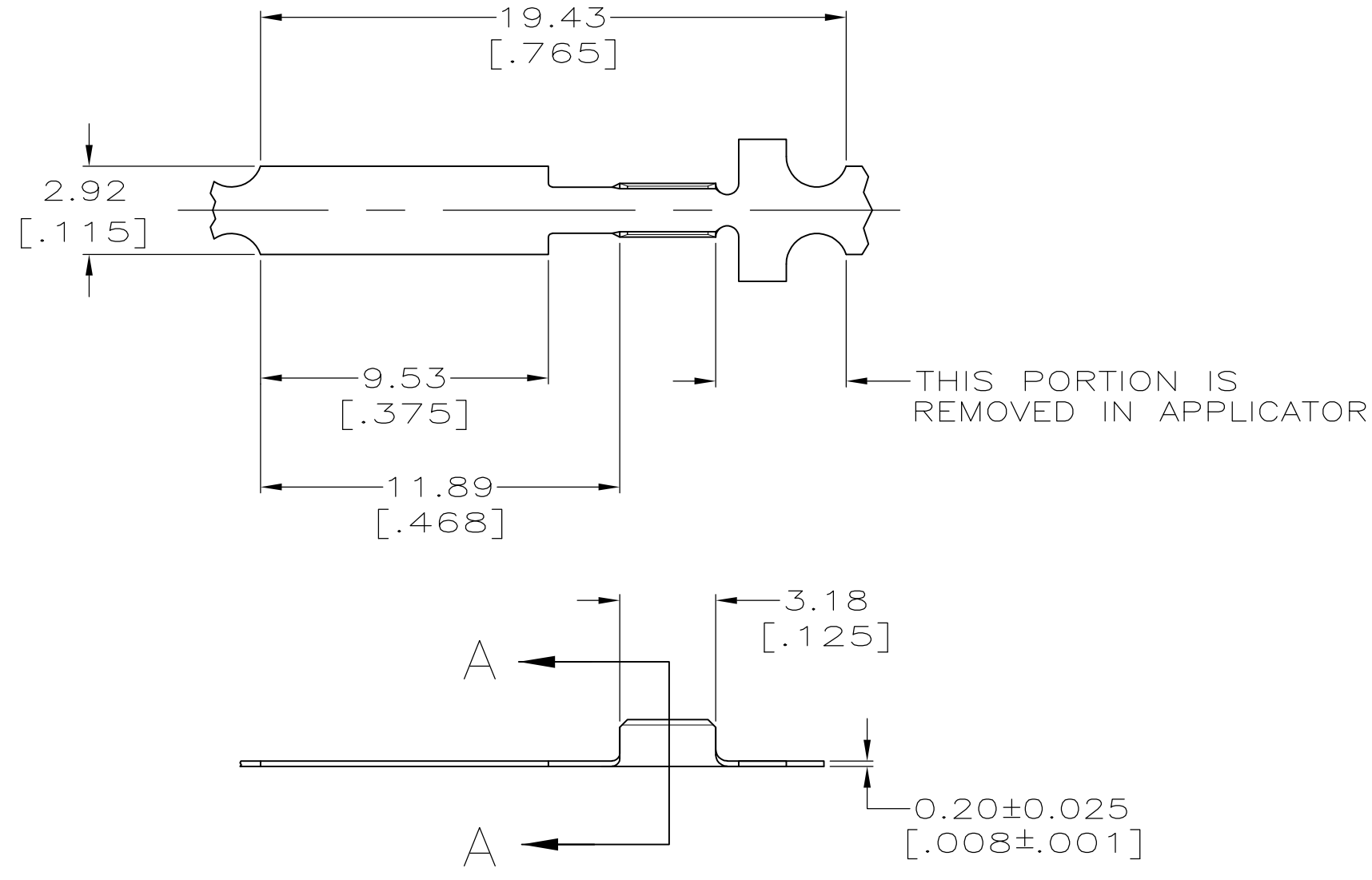

- 1 CONTINUOUS STRIP ON REELS.
- 2 WIRE SIZE IS [#24-#22] AWG.
- 3 WIRE RANGE IS #26-#22 AWG, -2 ONLY.
- 4 PRELIMINARY - NOT FOR PRODUCTION.
- 5 0.002032 [.000080] MIN TIN PLATE.
- 6 0.000381 [.000015] MIN TIN PLATE OVER 0.00127 [.000050] MIN NICKEL UNDERPLATE.

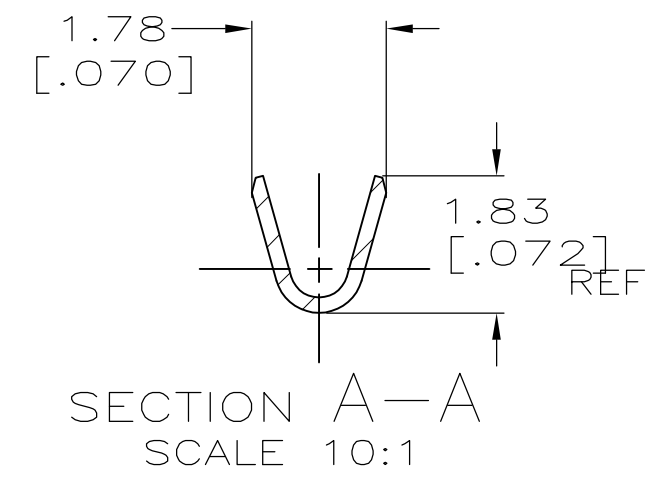

FINISH	MATERIAL	PART NO.
- 6	CARBON STEEL	4 62827-4
- 5	H04 BRASS	4 62827-3
-	1/4 H NICKEL	4 3 62827-2
-	STAINLESS STEEL	62827-1

THIS DRAWING IS A CONTROLLED DOCUMENT.		DWN JR RUTH 9JUL99	Tyco Electronics Corporation Harrisburg, Pa 17105-3608		
DIMENSIONS: mm		CHK MS FEHER 9JUL99	NAME TAB, WELD		
TOLERANCES UNLESS OTHERWISE SPECIFIED:		APVD E HOWARD 9JUL99	PRODUCT SPEC -		
0 PLC ± -		APPLICATION SPEC -	SIZE A3	CAGE CODE 00779	DRAWING NO G-62827
1 PLC ± -		RESTRICTED TO -	SCALE 5:1		
2 PLC ± 0.25 [.010]		SHEET 1 OF 1			
3 PLC ± -		REV D1			
4 PLC ± -		CUSTOMER DRAWING			
ANGLES ± -		SCALE 5:1 SHEET 1 OF 1 REV D1			
FINISH ± -		SCALE 5:1 SHEET 1 OF 1 REV D1			
MATERIAL SEE TABLE		SCALE 5:1 SHEET 1 OF 1 REV D1			
FINISH SEE TABLE		SCALE 5:1 SHEET 1 OF 1 REV D1			