

THIS DRAWING AND THE SUBJECT MATTER SHOWN THEREON ARE CONFIDENTIAL AND THE PROPERTY OF BEL/STEWART/TRP CONNECTOR AND SHALL NOT BE REPRODUCED, COPIED, OR USED IN ANY MANNER WITHOUT THE WRITTEN CONSENT OF TRP CONNECTOR.

PRODUCT MAY BE PROTECTED BY ONE OR MORE OF THE FOLLOWING US PATENTS:
 5736910 5939955 6425781 6428361 6554638 6840817 7123117
 7429195 7717749 7808751 6217391 6149050 7924130

REVISIONS				
P	LTN	DESCRIPTION	DATE	APPV
2		SEE LAST SHEET	14JAN2015	RL TY

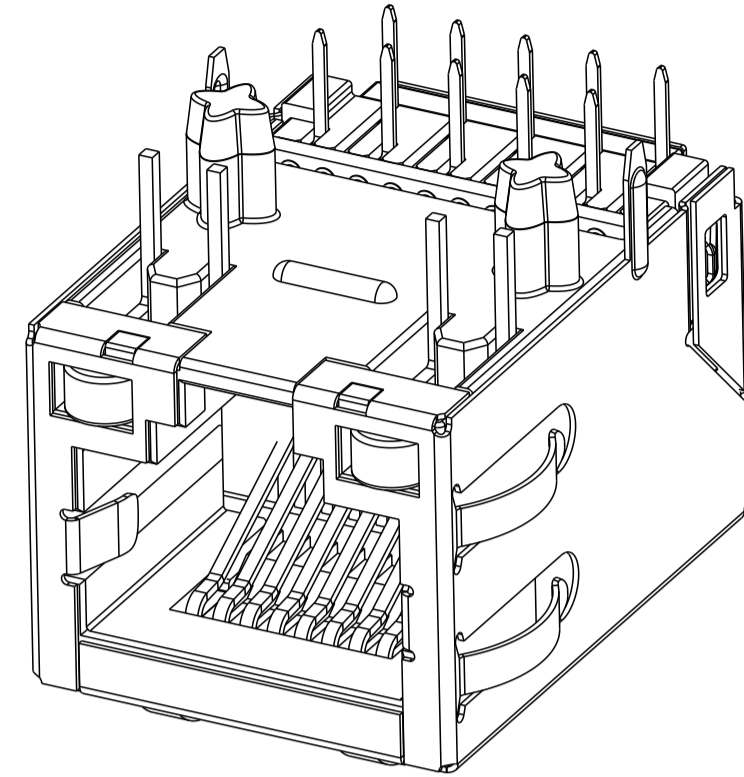
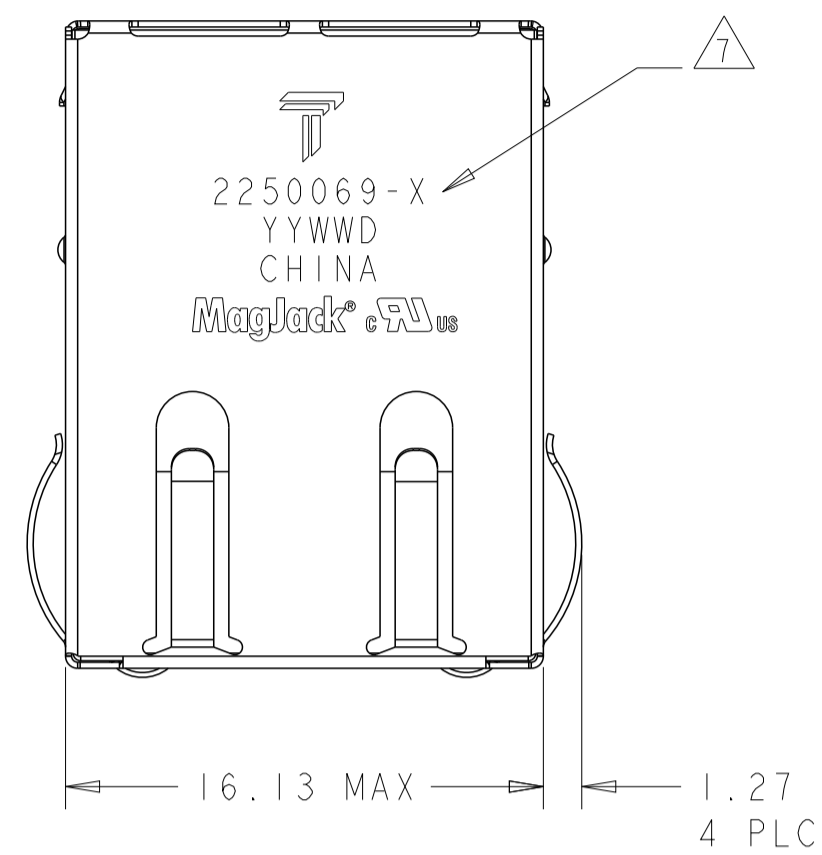

1. MATERIALS
- HOUSING: THERMOPLASTIC, FLAMMABILITY RATING UL 94V-0.
 - SHIELD: BRASS 0.20mm THICK, PREPLATED WITH 0.76um MIN SEMI-BRIGHT NICKEL. SOLDER TABS POST DIPPED WITH 2.54um MIN SAC SOLDER.
 - CONTACTS: PHOSPHOR BRONZE 0.46mm X 0.30mm, PHOSPHOR BRONZE, 1.27um MIN NICKEL UNDERPLATE, WITH 1.27um MIN GOLD PLATING AT MATING INTERFACE AND 2.54um MIN MATTE TIN ON SOLDER TAILS.
 - SOLDER TAILS: 0.25mm THICK, PHOSPHOR BRONZE, 1.27um MIN OVERALL NICKEL UNDERPLATE, 3um TIN PLATE
 - LIGHT EMITTING DIODE (LED): DIFFUSED EPOXY LENS, 0.5mm X 0.5mm CARBON STEEL WIREFRAME LEADS PREPLATED WITH 2.03um MIN. SILVER PLATE OVER 1.02um MIN. NICKEL OVER 1.02um MIN. COPPER UNDERPLATE; LEADS POST-PLATED WITH 3.05um MIN. MATTE TIN AND/OR SAC SOLDER DIP OR PURE TIN SOLDER DIP

2. RJ45 JACK CAVITY CONFORMS TO FCC RULES AND REGULATIONS PART 68 SUB PART F.

3. MAGNETICS
- APPLICATION: 10/100/1000 BASE-T
 - IMPEDANCE: 100 OHMS
 - TURNS RATIO (CHIP:CABLE): 1:1 ALL FOUR PAIRS
 - OPEN CIRCUIT INDUCTANCE (OCL): 350uH MIN. @100kHz, 0.1VRMS, 8mADC BIAS FROM 0°C TO 70°C, ALL FOUR PAIRS
 - ALL FOUR PAIRS BI-DIRECTIONAL
 - PERFORMANCE @ 25°C:
 - INSERTION LOSS (IL): 1.1dB MAX. FROM 0.5MHz TO 100MHz
 - RETURN LOSS (RL): 18dB MIN FROM 0.5MHz TO 40MHz
 - 12-20LOG(f/80)dB MIN. FROM 40.1MHz TO 100MHz
 - CROSSTALK ATTENUATION: 35dB MIN. FROM 0.5MHz TO 40MHz
 - 33-20LOG(f/50)dB MIN. FROM 40.1MHz TO 100MHz
 - COMMON MODE REJECTION RATIO (CMRR): 30dB MIN. FROM 0.5MHz TO 100MHz
 - ISOLATION VOLTAGE: 2250VDC FOR 60 SECONDS WITH A RISE TIME OF 500 V/SEC

4. OPERATING TEMPERATURE: FROM 0°C TO +70°C.

5. INDICATED MAGNETIC CONNECTIONS ARE SYMMETRICAL TO SUPPORT AUTO-MDI/MDIX.

6. LEDs ARE DRIVEN WITH CONSTANT CURRENT AT APPROX 20mA
 LED COLOR: DOMINATE WAVELENGTH (λD): GREEN 568 nm TYP. AT IF = 20mA
 FORWARD VOLTAGE (VF): GREEN 2.2V TYP. at IF = 20mA
 DOMINATE WAVELENGTH (λD): YELLOW 588 nm TYP. AT IF = 20mA
 FORWARD VOLTAGE (VF): YELLOW 2.1V TYP. at IF = 20mA

7. TRP CONNECTOR LOGO, PART NUMBER, DATE CODE, COUNTRY OF ORIGIN AND AGENCY APPROVAL MARKING IN APPROXIMATE LOCATION SHOWN.

8. THESE PARTS ARE RECOMMENDED FOR WAVE SOLDERING PROCESS, PREHEAT TEMPERATURE IS 120°C TO 160°C, 120 SECONDS TO 180 SECONDS, PEAK WAVE SOLDERING TEMPERATURE IS 260°C MAX, 10 SECONDS MAX.

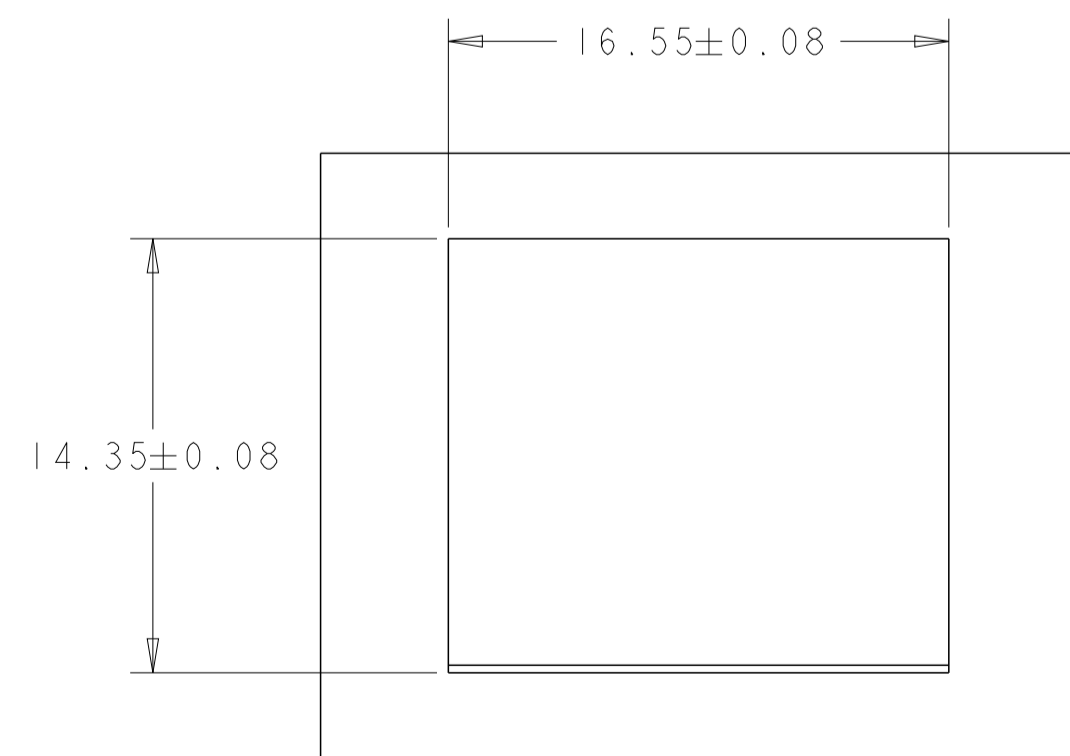
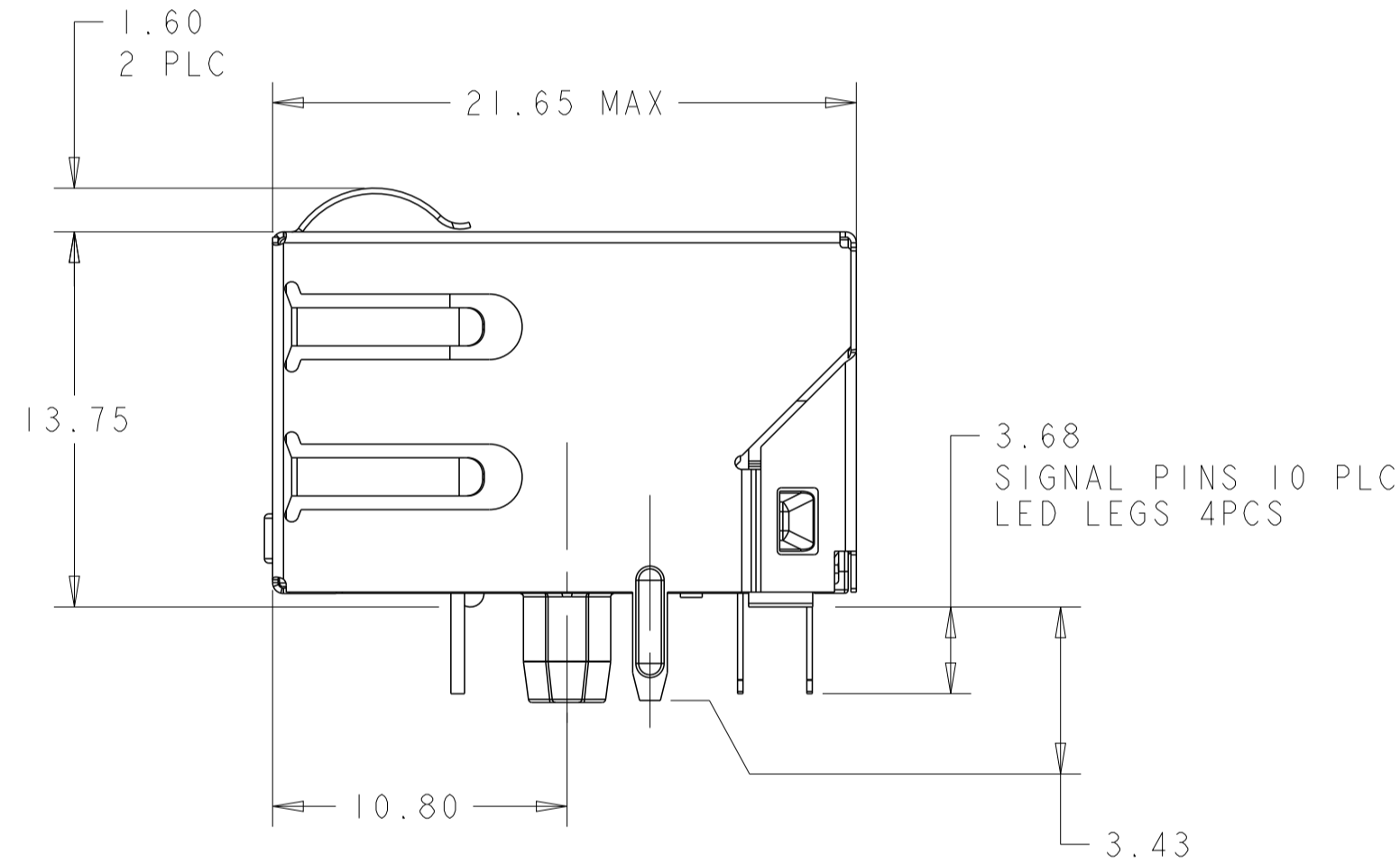
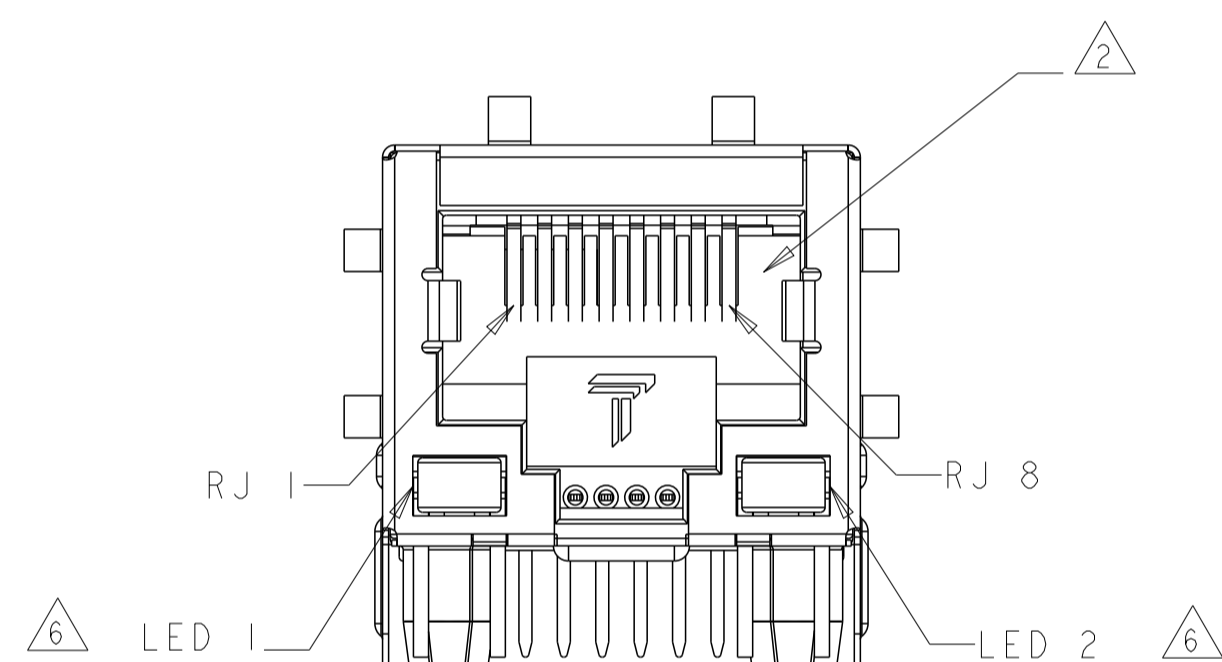

SUGGESTED PANEL CUTOUT
SCALE 4:1

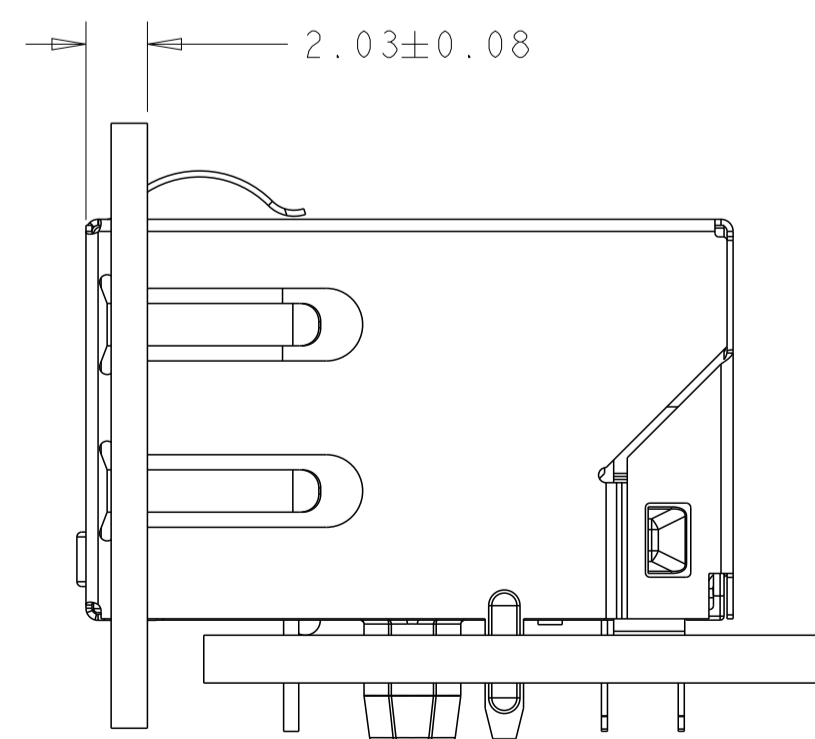

GREEN	-	YELLOW	-	2250069-2
GREEN	YELLOW	GREEN	YELLOW	2250069-1
11-12	12-11	13-14	14-13	PART NUMBER
LED 1		LED 2		

THIS DRAWING IS A CONTROLLED DOCUMENT.		OWN ROY LIU 30DEC2013	trp CONNECTOR a bel group		DONGGUAN CHINA										
DIMENSIONS: mm		CHK TOWER YU/FRANK LIU 30DEC2013	DESC IXI 4G01PI GIGABIT TAB DOWN W/ LED												
TOLERANCES UNLESS OTHERWISE SPECIFIED:		APPV TONY YUAN 30DEC2013	SIZE A1												
<table border="1"> <tr><td>0 PLC</td><td>±0.25</td></tr> <tr><td>1 PLC</td><td>±0.25</td></tr> <tr><td>2 PLC</td><td>±0.25</td></tr> <tr><td>3 PLC</td><td>±</td></tr> <tr><td>4 PLC</td><td>±</td></tr> </table>		0 PLC	±0.25	1 PLC	±0.25	2 PLC	±0.25	3 PLC	±	4 PLC	±	MODEL NAME MAGJACK	RESTRICTED TO		
0 PLC	±0.25														
1 PLC	±0.25														
2 PLC	±0.25														
3 PLC	±														
4 PLC	±														
PRODUCT SPEC 108-104004		APPLICATION SPEC -	C=2250069		SCALE 4:1 SHEET 1 OF 3 REV 2										
CUSTOMER DRAWING															

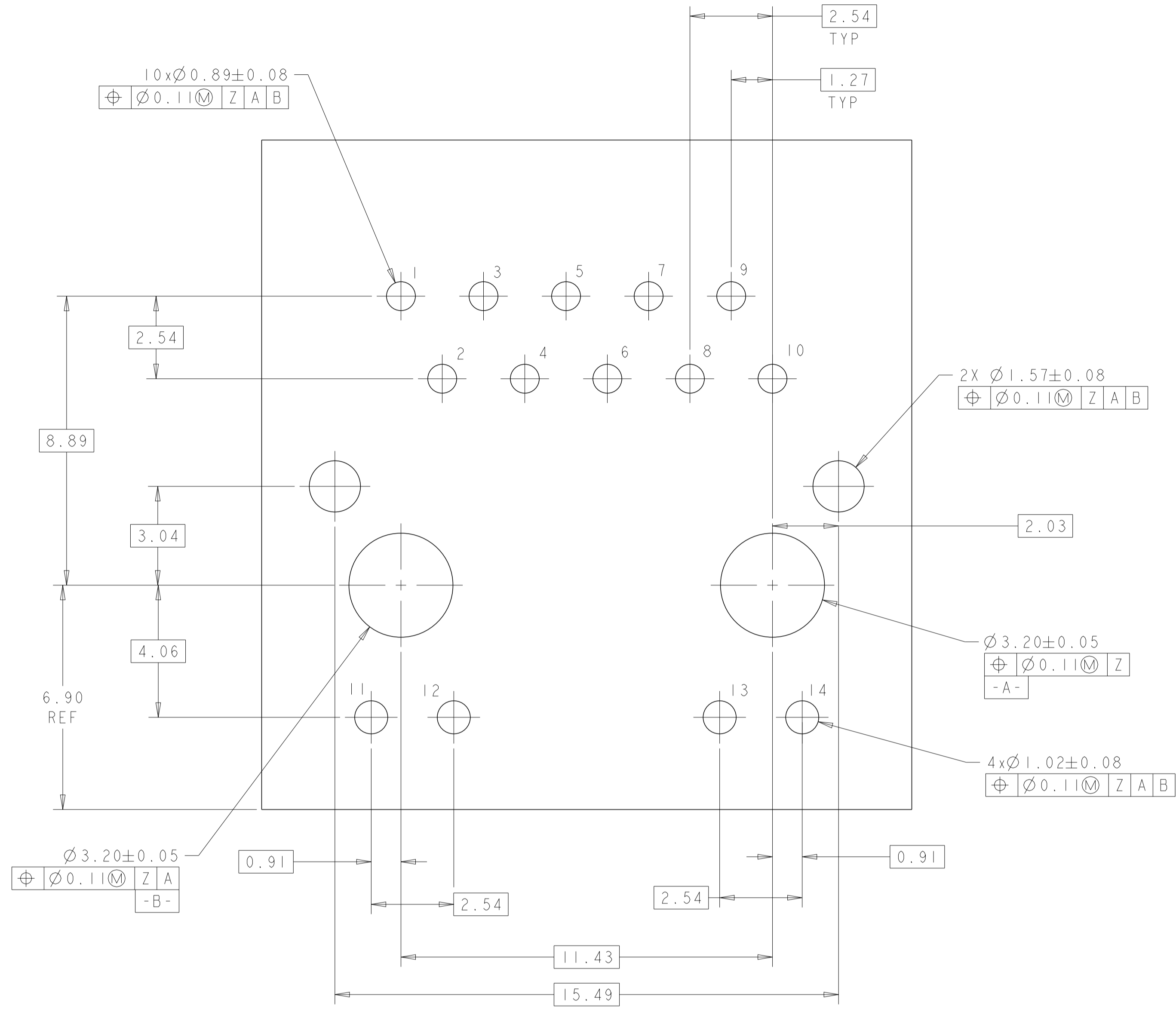

SUGGESTED PCB LAYOUT
 COMPONENT SIDE

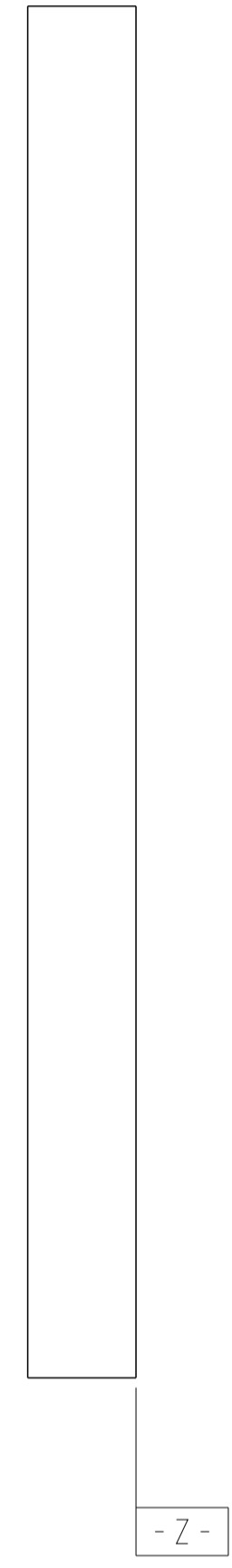

4G01PI GIGABIT MAGNETIC CIRCUIT $\triangle 3 \triangle 5$

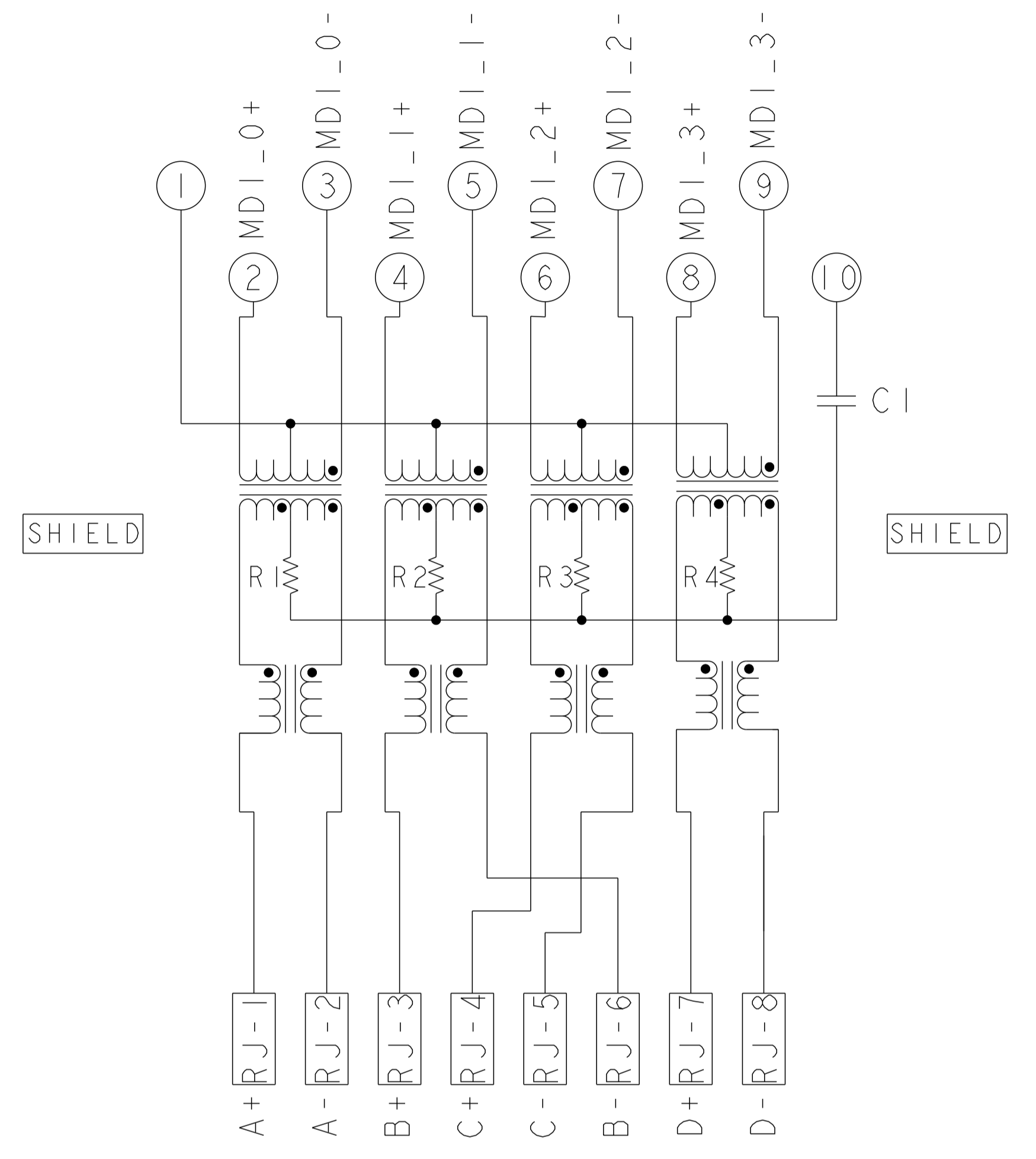

C1=1000pF. 2kV CAPACITOR
 R1-R4 = 75 Ohms RESISTORS

THIS DRAWING IS A CONTROLLED DOCUMENT.		OWN ROY LIU 30DEC2013	 trp CONNECTOR a bel group DONGGUAN CHINA
DIMENSIONS: mm		CHK TOWER YU/FRANK LIU 30DEC2013	
TOLERANCES UNLESS OTHERWISE SPECIFIED:		APP'D TONY YUAN 30DEC2013	MODEL NAME MAGJACK
0 PLC ± 0.25 1 PLC ± 0.25 2 PLC ± 0.25 3 PLC ± 0.25 4 PLC \pm ANGLES \pm APPLICATION SPEC \pm		DESC IXI 4G01PI GIGABIT TAB DOWN W/ LED	SIZE A1
PRODUCT SPEC 108-104004		CUSTOMER DRAWING	SCALE 4:1 SHEET 2 OF 3 REV 2

C_2250069					STOCK DISPOSITION			
REVISION HISTORY					A: CONTINUE AS IS B: REWORK C: SCRAP			
					D: USE OLD FIRST E: PARTS TO CONFORM F: OTHER			
DATE	REV	CHANGES	REASON	APPROVAL	INVENTORY (A,B,C,D,E,F)	WORK IN PROCESS (A,B,C,F)	SUPPLIER ORDERS (A,E,F)	OPEN CUST ORDERS (A,E,F)
30DEC2013	1	-	INITIAL RELEASE	TONY YUAN	-	-	-	-
14JAN2015	2	EC-1411035 COMPANY LOGO CHANGE	MARKET REQUIREMENT	TONY YUAN	-	-	-	-

THIS DRAWING IS A CONTROLLED DOCUMENT.		OWN ROY LIU	30DEC2013	 trp CONNECTOR <small>a bel group</small>	DONGGUAN CHINA
DIMENSIONS: mm		CHK TOWER YU/FRANK LIU	30DEC2013		
TOLERANCES UNLESS OTHERWISE SPECIFIED:		APP'D TONY YUAN	30DEC2013		
0 PLC ±0.25 1 PLC ±0.25 2 PLC ±0.25 3 PLC ± 4 PLC ± ANGLES ± APPLICATION SPEC ±		MODEL NAME MAGJACK	DESC IXI 4G01PI GIGABIT TAB DOWN W/ LED		
PRODUCT SPEC 108-104004	APPLICATION SPEC -	SINGLE Non-PoE	A1	SIZE A1	CAGE CODE C=2250069
CUSTOMER DRAWING		SCALE 4:1	SHEET 3	OF 3	REV 2