

REVISIONS

P	LTR	DESCRIPTION	DATE	DWN	APVD
	C	REVISED PER ECR-15-018040	12DEC2015	T.S	E.T

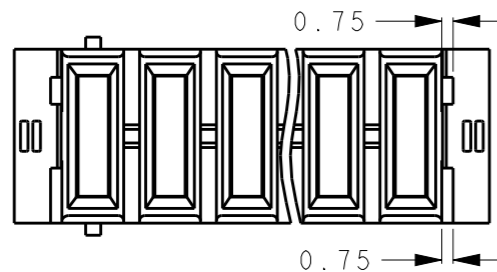

- ① MATERIAL HOUSING: POLYESTER OF GLASS FILLED THERMO PLASTIC(UL94V-0), COLOR:BLACK
CONTACT: COPPER ALLOY
- ② FINISH CONTACT UNDER: Ni PLATING ALL SURFACE 1.27μm MIN
CONTACT AREA: Au PLATING 0.2μm MIN
P.C.BOARD ATTACHMENT AREA: TIN PLATING 2μm MIN
RETENTION LEG ALL SURFACE: TIN PLATING 2μm MIN OVER Ni PLATING ALL SURFACE 1.27μm MIN
- ③ AS FOR 2/5/6-3(10.16mmPITCH:3POS), EVEN NUMBER CIRCUITS(NO.2 AND 4) ARE NOT EQUIPPED WITH CONTACT.
- ④ AS FOR 5--4(10.16mmPITCH:4POS), EVEN NUMBER CIRCUITS(NO.2,4 AND 6) ARE NOT EQUIPPED WITH CONTACT.

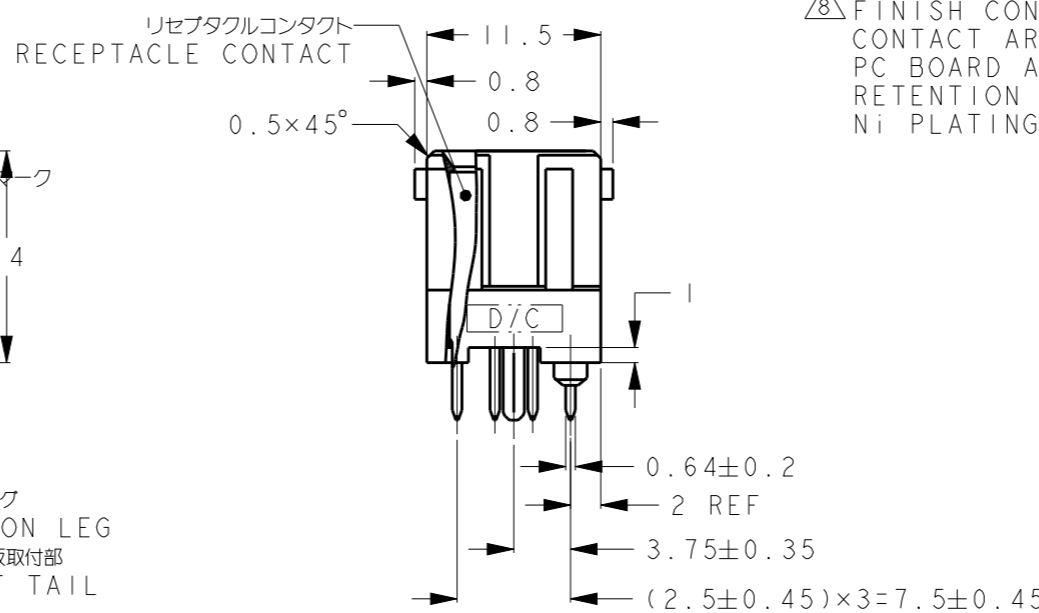
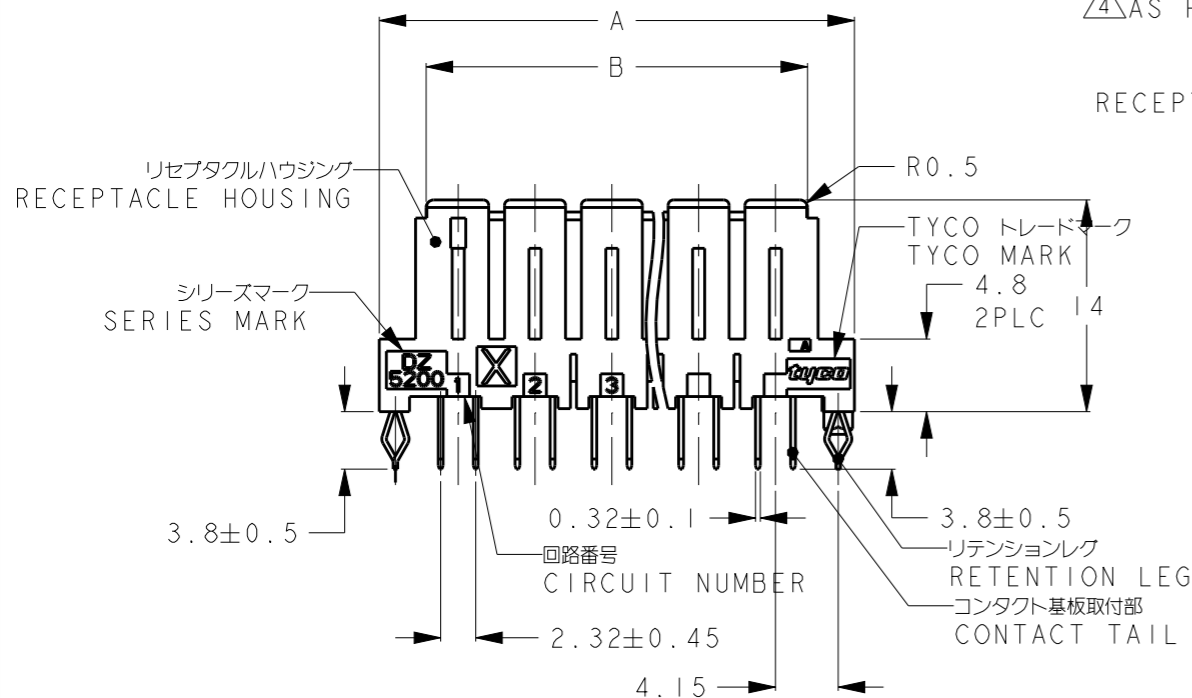

- ⑤ FINISH CONTACT UNDER: Ni PLATING ALL SURFACE 1.27μm MIN
CONTACT AREA: Au PLATING 0.76μm MIN
PC BOARD ATTACHMENT AREA: TIN PLATING 2μm MIN
RETENTION LEG ALL SURFACE: TIN PLATING 2μm MIN OVER Ni PLATING ALL SURFACE 1.27μm MIN

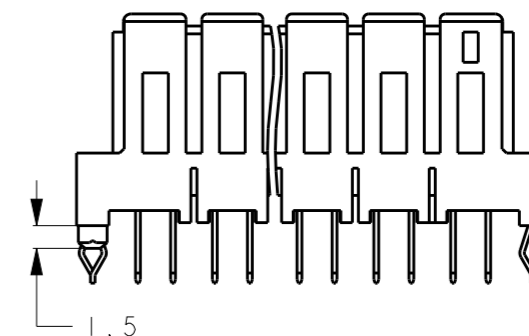

⑨ FOR 2-1747147-3, SEE SHEET 4 AND 5

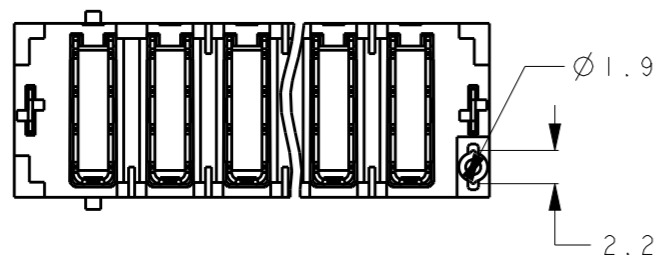

MATING CONNECTOR PART NUMBER	WEIGHT (g)	D	C	B	A	N	PITCH	POS	FINISH	PART NO
1554403-3									⑨	2-1747147-3
6-1747145-3	5.03	28.62	20.32	24.56	30.76	4	10.16	3/3	⑧	6-1747147-3
1-1747145-7	8.83	38.78	30.48	34.72	40.92	6	5.08	7	②	1-1747147-7
1-1747145-5	6.47	28.62	20.32	24.56	30.76	4	5.08	5	②	1-1747147-5
5-1747145-4	6.68	38.78	30.48	34.72	40.92	6	10.16	4/4	②	5-1747147-4
5-1747145-3	5.03	28.62	20.32	24.56	30.76	4	10.16	3/3	②	5-1747147-3

適用寸法(D) DIMENSION APPLIED(D)	一般公差 GENERAL TOLERANCE
0<D≤10	±0.3
10<D≤30	±0.4
30<D≤100	±0.45

THIS DRAWING IS A CONTROLLED DOCUMENT.

DWN K.RIKU 10FEB05
CHK D.MITSUGI 10FEB05
APVD D.MITSUGI 10FEB05

NAME 名称 DYNAMIC DZ5200
製品規格 108-78186
APPLICATION SPEC 取付適用規格

WEIGHT

CUSTOMER DRAWING

SCALE 2:1 SHEET 1 OF 5 REV C

RESTRICTED TO

REVISIONS					
P	LTR	DESCRIPTION	DATE	DWN	APVD
-	-	SEE SHEET 1	-	-	-

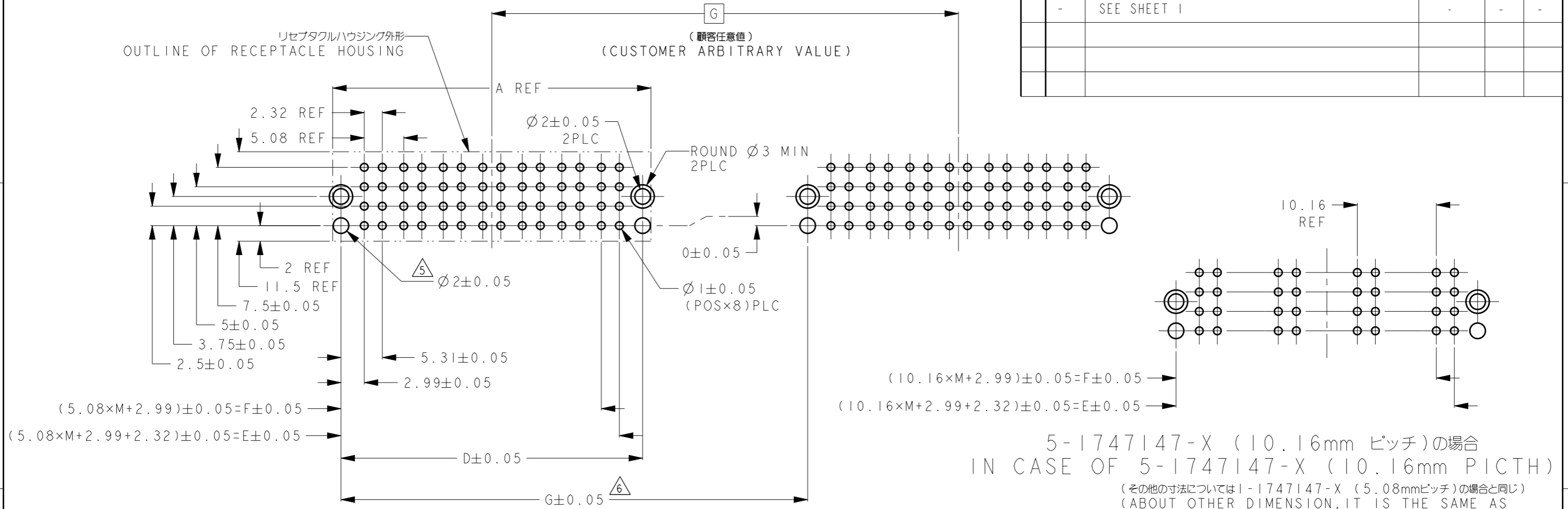

1-1747147-X (5.08mm ピッチ)の場合
 IN CASE OF 1-1747147-X (5.08mm PICTH)

5-1747147-X (10.16mm ピッチ)の場合
 IN CASE OF 5-1747147-X (10.16mm PICTH)
 (その他の寸法については1-1747147-X (5.08mmピッチ)の場合と同じ)
 (ABOUT OTHER DIMENSION, IT IS THE SAME AS THE CASE OF 1-1747147-X (5.08mm PICTH.))

推奨基板取付穴寸法 (コネクタ搭載面) 適用基板厚: 1.6±0.1

RECOMEND PC BOARD HOLE PATTERN (CONNECTOR MOUNT SIDE), PC BOARD THICKNESS: 1.6±0.1

△5 THE HOLE FOR DECIDING THE POSITION WHICH MOUNTS THE CONNECTOR.
 △6 WHEN TWO OR MORE CONNECTORS ON ONE PC BOARD ARE USED WHEN PROCESSING BY THE HOLE (△5) POSITION DIMENSION TOLERANCE CANNOT BE PERFORMED, ONLY ONE CONNECTOR SHOULD BE USED PER ONE PC BOARD. (WHEN PROCESSING BY THE HOLE (△6) POSITION DIMENSION TOLERANCE CAN BE PERFORMED, TWO OR MORE CONNECTOR CAN BE USED PER ONE PC BOARD.)

顧客任意値 CUSTOMER ARBITRARY VALUE	23.31	25.63	28.62	30.76	2	10.16	3/3	6-1747147-3
	33.47	35.79	38.78	40.92	6	5.08	7	1-1747147-7
	23.31	25.63	28.62	30.76	4	5.08	5	1-1747147-5
	33.47	35.79	38.78	40.92	3	10.16	4/4	5-1747147-4
	23.31	25.63	28.62	30.76	2	10.16	3/3	5-1747147-3
G	F	E	D	A	M PITCH		POS	PART NO
DIMENSION								

THIS DRAWING IS A CONTROLLED DOCUMENT.		DWN K. RIKU 10FEB05	 TE Connectivity	
DIMENSIONS: mm		CHK D. MITSUGI 10FEB05		
TOLERANCES UNLESS OTHERWISE SPECIFIED: ±		APVD D. MITSUGI 10FEB05	NAME DYNAMIC DZ5200 VERTICAL RECEPTACLE ASSY	
0 PLC ± 1 PLC ± 2 PLC ± 3 PLC ± 4 PLC ± ANGLES ±3°		PRODUCT SPEC 108-78186	RESTRICTED TO	
MATERIAL		APPLICATION SPEC -	SIZE A3	CAGE CODE -
FINISH		WEIGHT -	DRAWING NO C=1747147	SCALE 2:1
		CUSTOMER DRAWING	SHEET 2 OF 5	REV C

THIS DRAWING IS UNPUBLISHED.

RELEASED FOR PUBLICATION

2010

© COPYRIGHT 2010 BY -

ALL RIGHTS RESERVED.

REVISIONS

P	LTR	DESCRIPTION	DATE	DWN	APVD
	-	SEE SHEET 1	-	-	-

7 THE CAUTION ON THE HANDLING OF THE CONNECTOR

(1) MOUNTING OPERATION ONTO PC BOARD

AFTER MOUNTED ONTO PC BOARD, PLEASE CHECK THAT THERE ARE NO FLOAT IN BOTH SIDE SURFACE OF THE CONNECTOR, AND DO SOLDERING WORK.

MOREOVER, PLEASE DO NOT RE-USE OF THE CONNECTOR REMOVED FROM THE PC BOARD AT ONCE. (SINCE MOUNTING POSITION ACCURACY FALLS.)

(2) MATING OPERATION

THE MATING OPERATION SHOULD BE MADE AFTER CONFIRMING NO EXCESSIVE GAP OR INCLINATION THROUGH A LIGHT MATING OF HEADER CONNECTOR AND RECEPTACLE CONNECTOR.

REGULATION OF THE DEGREE

CONNECTOR PITCH DIRECTION: THE DEGREE MUST BE LESS THAN 5 DEGREES.

CONNECTOR THICKNESS DIRECTION: THE DEGREE MUST BE LESS THAN 10 DEGREES.

(3) REMOVAL OPERATION

TO UNMATE MATED PC BOARDS, IT IS BEST TO HOLD THE PC BOARD AT A OPERATION ADJACENT TO THE CONNECTOR AND EXTRACT IN A STRAIGHT MANNER.

IN THE EVENT THAT THE EXTRACTION FORCE IS HIGH, IT MAY BE EASIER TO UNMATE THE PC BOARD BY TILTING IT IN ONE DIRECTION WHILE EXTRACTING.

HOWEVER, THIS TILT MUST BE KEPT WITHIN 5 DEGREES (PITCH DIRECTION) AND 10 DEGREES (THICKNESS DIRECTION).

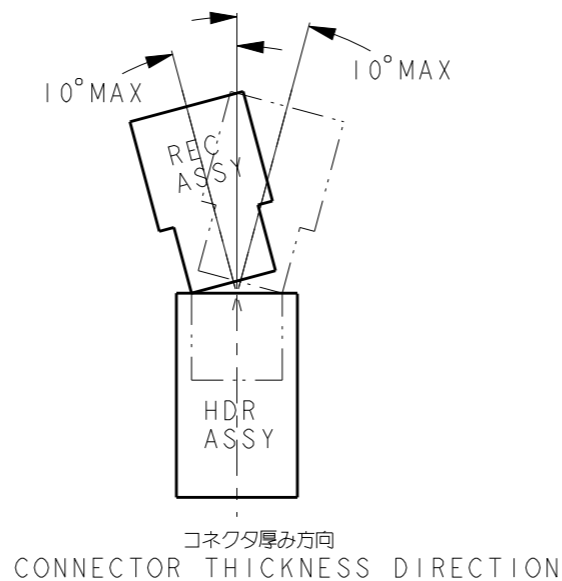
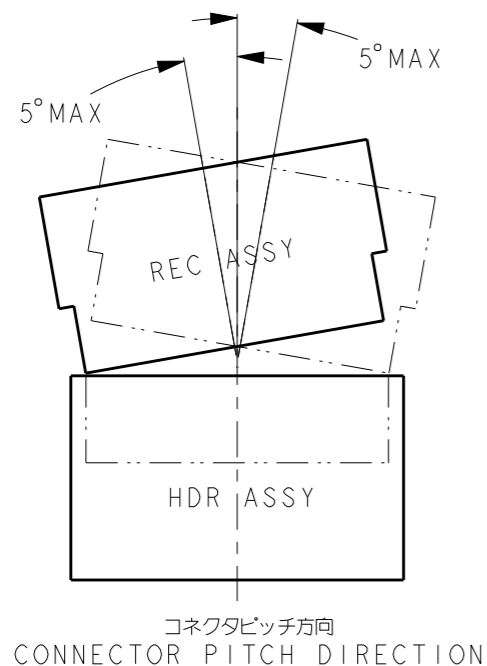

THIS DRAWING IS A CONTROLLED DOCUMENT.

DIMENSIONS:

mm

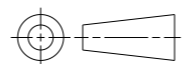

TOLERANCES UNLESS OTHERWISE SPECIFIED:

± -

Ø PLC	±
1 PLC	±
2 PLC	±
3 PLC	±
4 PLC	±
ANGLES	±3°

MATERIAL

FINISH

DWN K.RIKU 10FEB05

CHK D.MITSUGI 10FEB05

APVD D.MITSUGI 10FEB05

PRODUCT SPEC 108-78186

APPLICATION SPEC -

WEIGHT -

CUSTOMER DRAWING



TE Connectivity

NAME DYNAMIC DZ5200 VERTICAL RECEPTACLE ASSY

SIZE CAGE CODE DRAWING NO RESTRICTED TO

A3 - C-1747147

SCALE 2:1 SHEET 3 OF 5 REV C

REVISIONS

P	LTR	DESCRIPTION	DATE	DWN	APVD
-	-	SEE SHEET 1	-	-	-

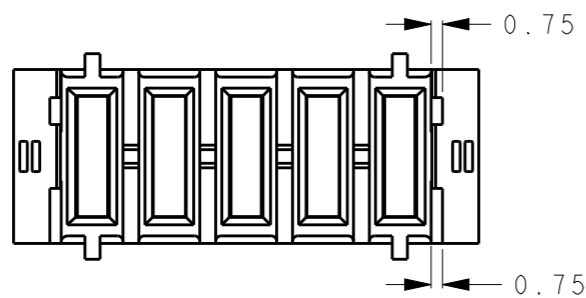

2-1747147-3の形状
2-1747147-3: AS SHOWN

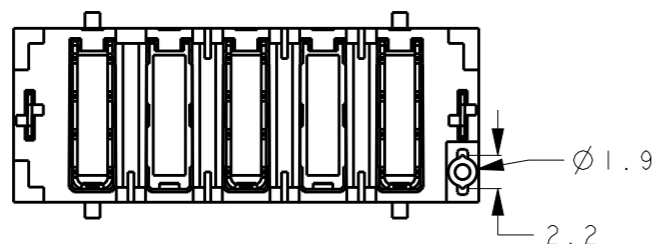
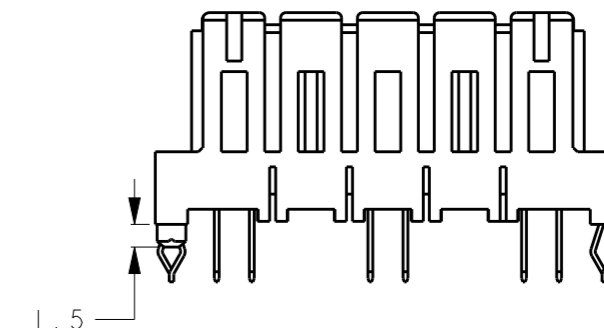
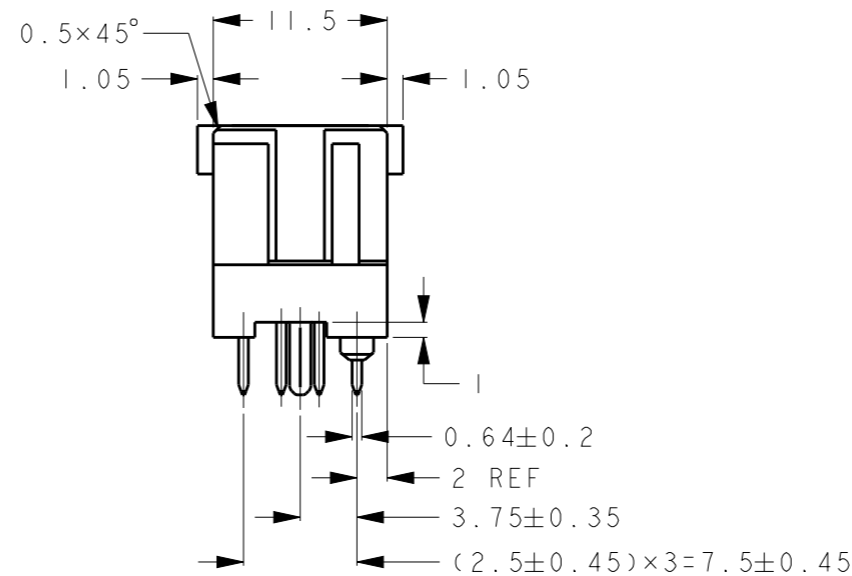
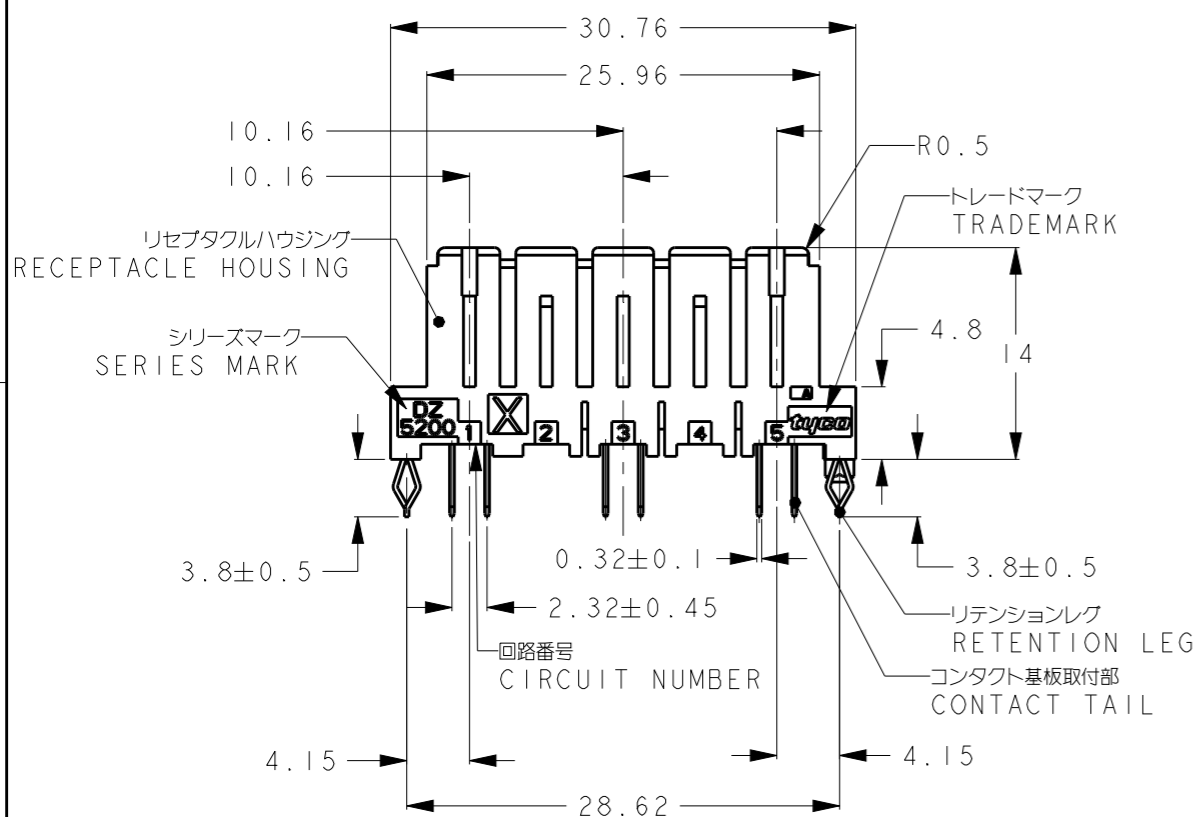

1554403-3	5.08	10.16	3 Δ 3	2-1747147-3
MATING CONNECTOR PART NUMBER	WEIGHT (g)	PITCH	POS	PART NUMBER

THIS DRAWING IS A CONTROLLED DOCUMENT.		DWN	-	TE Connectivity NAME DYNAMIC DZ5200 VERTICAL RECEPTACLE ASSY	
DIMENSIONS: mm		CHK	-		
TOLERANCES UNLESS OTHERWISE SPECIFIED: ±0.3		APVD	-		
0-PLC ± 1-PLC ± 2-PLC ± 3-PLC ± 4-PLC ± ANGLES ±3°		PRODUCT SPEC	-		
MATERIAL Δ 1		FINISH Δ 2	APPLICATION SPEC	-	RESTRICTED TO
		WEIGHT	-	SIZE A3	CAGE CODE -
		CUSTOMER DRAWING		DRAWING NO. C-1747147	SCALE 2:1
				SHEET 4 OF 5	REV C

4

3

2

1

THIS DRAWING IS UNPUBLISHED.

RELEASED FOR PUBLICATION

2010

© COPYRIGHT 2010 BY -

ALL RIGHTS RESERVED.

REVISIONS

P	LTR	DESCRIPTION	DATE	DWN	APVD
-	-	SEE SHEET 1	-	-	-

リセプタクルハウジング外形
OUTLINE OF RECEPTACLE HOUSING

30.76 REF
2.32 REF
10.16 REF
7.5±0.05
5±0.05
3.75±0.05
2.5±0.05
2 REF
11.5 REF
2.99±0.05
5.31±0.05
13.15±0.05
15.47±0.05
23.31±0.05
25.63±0.05
28.62±0.05
ROUND Ø3
2PLC
Ø2±0.05
2PLC

2-1747147-3: AS SHOWN

5° MAX
5° MAX
5° MAX
5° MAX
REC ASSY
PLUG ASSY

2-1747147-3の推奨基板取付穴寸法(コネクタ搭載面) 適用基板厚: 1.6±0.1
RECOMEND PC BOARD HOLE PATTERN FOR 2-1747147-3
(CONNECTOR MOUNT SIDE), PC BOARD THICKNESS: 1.6±0.1

リセプタクルコネクタ中心
CENTERLINE OF REC ASSY

プラグコネクタ中心
CENTERLINE OF PLUG ASSY

0.5MAX
0.5MAX

△ 2-1747147-3の嵌合傾き許容量
PERMISSIBLE TILT WHEN MATING FOR 2-1747147-3

△ HOLE FOR POSITIONING OF CONNECTOR MOUNTING.
△ USAGE NOTE

(1) DESIGN OF CIRCUIT BOARD
DESIGN OF CIRCUIT BOARD SHOULD BE MADE SURE THAT MISALIGNMENT TO MATING CONNECTOR IS 0.5mmMAX (SEE LEFT FIGURE).

(2) MOUNTING OPERATION ONTO CIRCUIT BOARD
AFTER MOUNTED ONTO CIRCUIT BOARD, CHECK THAT THERE IS NO FLOAT FROM THE CIRCUIT BOARD, AND THEN DO SOLDERING WORK
DO NOT RE-USE THE CONNECTOR REMOVED FROM THE CIRCUIT BOARD AT ONCE.

(3) MATING OPERATION
MATING OPERATION SHOULD BE DONE IN ACCORDANCE WITH FOLLOWING CONDITION.
MISALIGNMENT TO MATING CONNECTOR : 0.5mmMAX (SEE LEFT FIGURE)
INCLINATION TO MATING CONNECTOR : 5° MAX (SEE ABOVE FIGURE)
INCLINATION TO MATING CONNECTOR SHOULD BE MAINTAINED WITHIN 5° EVEN UNMATING.

△ 2-1747147-3の嵌合位置ズレ許容量
PERMISSIBLE MISALIGNMENT OF MATING FOR 2-1747147-3

THIS DRAWING IS A CONTROLLED DOCUMENT.		DWN	-	TE Connectivity	
DIMENSIONS:		CHK	-		
mm		APVD	-		
TOLERANCES UNLESS OTHERWISE SPECIFIED:		PRODUCT SPEC	-		
		APPLICATION SPEC	-	NAME DYNAMIC DZ5200 VERTICAL RECEPTACLE ASSY	
0 PLC ± 1 PLC ± 2 PLC ± 3 PLC ± 4 PLC ± ANGLES ±3°		WEIGHT	-	SIZE	A3
MATERIAL		FINISH		CAGE CODE	-
				DRAWING NO	1747147
				RESTRICTED TO	-
		CUSTOMER DRAWING		SCALE	2:1
				SHEET	5 OF 5
				REV	C

1470-19 (3/13)