

# ETW.375 | Spoked handwheels

Technopolymer



## MATERIAL

High-resilience polypropylene based (PP) technopolymer, black colour, matte finish.

## BOSS CAP

Polyester based technopolymer (PBT) in Ergostyle colours, glossy finish, press-fit mounting.

Available also as accessory sold separately (see table ECB.).

Code	Description	Boss cap for
29451-*	ECB.I3-*	ETW.375

\* Complete with colour index (C1, ..., C6).

## STANDARD EXECUTIONS

Black-oxide steel boss, H7 reamed hole.

- **ETW.375+IEL:** with revolving handle IEL+x-SOFT (see page 629) in technopolymer coated with "Soft touch" thermoplastic elastomer (TPE).
- **ETW.375+IR:** with fold-away handle IR.620 (see page 674) in technopolymer.

## SPECIAL EXECUTIONS ON REQUEST

Bosses with hole and keyway in compliance with DIN 6885/1 tolerance P9 (see page A-15).

To order the handwheel with keyway add the index -K after the code and the description (i.e. 205291-K- ETW.375+IEL A-20-K).

For sufficient quantities: executions with locking device (Elesa patent), (see page 170).

## ACCESSORIES ON REQUEST

Axial retaining washer GN 184 (see page 1021).



ERGOSTYLE® ELESA Original design

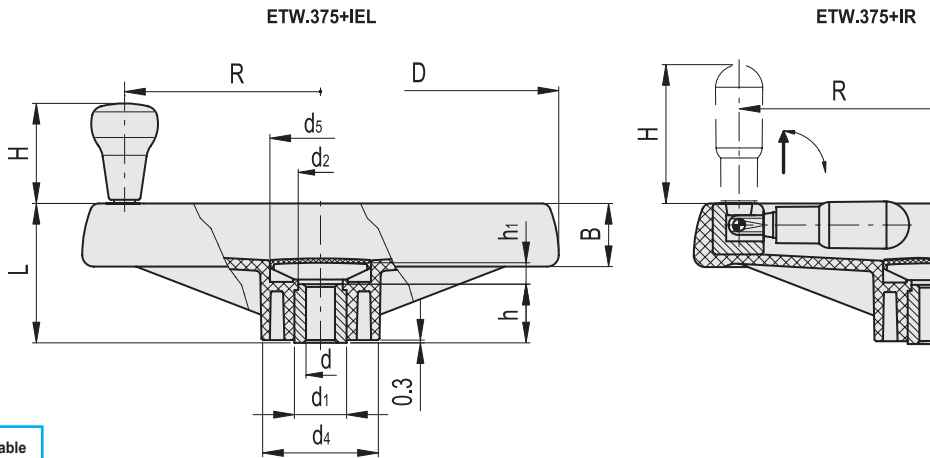

Conversion Table	
1 mm = 0.039 inch	
D	
mm	inch
375	14.76



\* Complete with colour index, example: 205291-C2 ETW.375+IEL A-20-C2

- C1**  
RAL7021
- C2**  
RAL2004
- C3**  
RAL7035
- C4**  
RAL1021
- C5**  
RAL5024
- C6**  
RAL3000

## ETW.375+IEL

METRIC

Code	Description	D	dH7	L	B	d1	d2	d4	d5	h	h1	H	R	C# [Nm]	L# [J]	⚖️
205291-*	ETW.375+IEL A-20-*	375	20	86	38	35	33	80	70	38	14	65	160	380	55	1260

## ETW.375+IR

Code	Description	D	dH7	L	B	d1	d2	d4	d5	h	h1	H	R	C# [Nm]	L# [J]	⚖️
205491-*	ETW.375+IR A-20-*	375	20	86	38	35	33	80	70	38	14	90	160	380	55	1350

# For maximum torque (C) and impact strength (L) see Technical Data on page A-3 A-3.

Models all rights reserved in accordance with the law. Always mention the source when reproducing our drawings and photos.



Operating elements

