

8-CHANNEL ELECTRONIC VOLUME

■ GENERAL DESCRIPTION

The **NJU72343** is a 8-channel electronic volume that controlled independently. It has a 2-input selector for 4 of 8-channels. Functions are controlled via two-wired serial bus.

The **NJU72343** is well-suited for multi-channel audio systems such as AV amplifiers, DVD receivers and others.

■ PACKAGE OUTLINE

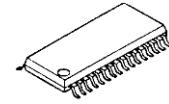

NJU72343V

■ FEATURES

- Operating Voltage
- 2-wired Serial BUS Control
- Selectable 2-Chip Address
- Volume
- Zero-cross Detection
- CMOS Technology
- Package Outline

Dual power supply: ± 4.5 to ± 7.5 V
 Single power supply: +9.0 to +15.0V

Available for using two chips on same serial bus line
 +31.5 to -95dB/0.5dB step, Mute

SSOP32

■ BLOCK DIAGRAM

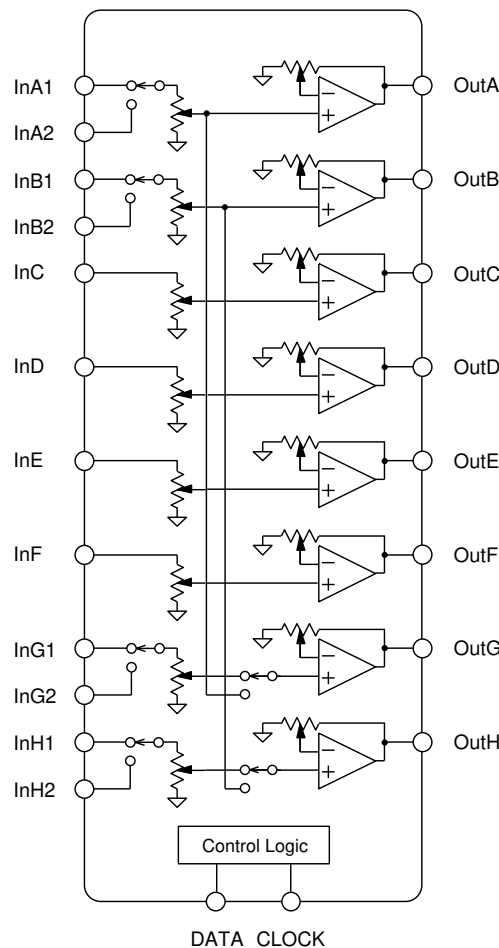

NJU72343

■ PIN CONFIGURATION

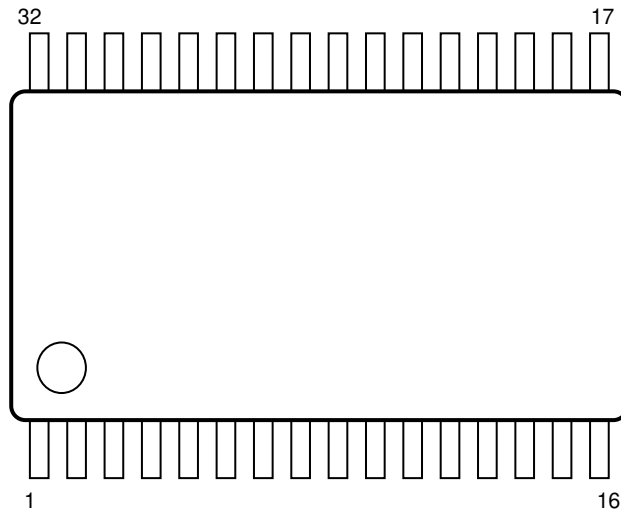

No.	Symbol	Function		Symbol	Function
1	AREF	Analog block reference voltage terminal	17	DATA	Control data signal Input terminal
2	ADR	Chip address setting terminal	18	CLOCK	Clock signal Input terminal
3	InA2	Ach Input terminal 2	19	VDDOUT	Digital block power supply Output terminal
4	InB2	Bch Input terminal 2	20	AREF	Analog block reference voltage terminal
5	InA1	Ach Input terminal 1	21	OutH	Hch Output terminal
6	InB1	Bch Input terminal 1	22	OutG	Gch Output terminal
7	InC	Cch Input terminal	23	OutF	Fch Output terminal
8	InD	Dch Input terminal	24	OutE	Ech Output terminal
9	InE	Ech Input terminal	25	OutD	Dch Output terminal
10	InF	Fch Input terminal	26	OutC	Cch Output terminal
11	InG1	Gch Input terminal 1	27	OutB	Bch Output terminal
12	InH1	Hch Input terminal 1	28	OutA	Ach Output terminal
13	InG2	Cch Input terminal 2	29	AREF	Analog block reference voltage terminal
14	InH2	Dch Input terminal 2	30	V-	Power supply (-)
15	MUTE	External mute control terminal	31	AREF	Analog block reference voltage terminal
16	REF	Digital block reference voltage terminal	32	V+	Power supply (+)

■ ABSOLUTE MAXIMUM RATING (Ta=25°C)

PARAMETER	SYMBOL	RATING	UNIT
Supply Voltage	V ⁺ /V ⁻	±8	V
Maximum Input Voltage	V _{IM}	V ⁺ /V ⁻	V
Power Dissipation	P _D	1200 NOTE: EIA/JEDEC STANDARD Test board (76.2x114.3x1.6mm, 2layer, FR-4) mounting	mW
Operating Temperature Range	Topr	-40 to +85	°C
Storage Temperature Range	Tstg	-40 to +150	°C

■ RECOMMENDED OPERATING VOLTAGE RANGE (Ta=25°C unless otherwise specified)

PARAMETER	SYMBOL	TEST CONDITION	MIN.	TYP.	MAX.	UNIT
Operating Voltage Range	V ⁺ /V ⁻		±4.5	±7.0	±7.5	V

■ ELECTRICAL CHARACTERISTICS (Ta=25°C, V⁺/V⁻=±7V, R_L=47kΩ, Volume=0dB unless otherwise specified)

◆DC CHARACTERISTICS

PARAMETER	SYMBOL	TEST CONDITION	MIN.	TYP.	MAX.	UNIT
Supply Current1	I _{DD}	No Signal (V ⁺)	-	21	35	mA
Supply Current2	I _{SS}	No Signal (V ⁻)	-	21	35	mA

◆AC CHARACTERISTICS

PARAMETER	SYMBOL	TEST CONDITION	MIN.	TYP.	MAX.	UNIT
Maximum Output Voltage	V _{OM}	f=1kHz, THD=1%, Volume=0dB	3.6	4.2	-	V _{rms}
Maximum Input Voltage	V _{IM}	f=1kHz, THD=1%, Volume=-20dB	4.7	-	-	V _{rms}
Voltage Gain 1	G _{V1}	f=1kHz, V _{IN} =2V _{rms} , Volume=0dB	-0.5	0	+0.5	dB
Voltage Gain 2	G _{V2}	f=1kHz, V _{IN} =100mV _{rms} , Volume=+15dB	+14	+15	+16	dB
Voltage Gain Error	ΔG _V	f=1kHz, V _{IN} =2V _{rms} , Volume=0dB	-1	0	+1	dB
Maximum Attenuation	A _{TT}	f=1kHz, V _{IN} =2V _{rms} , Volume=Mute, A-weight	-	-120	-	dB
Attenuation Error	ΔA _{TT}	f=1kHz, V _{IN} =2V _{rms} , Volume=-60dB	-1	0	+1	dB
Output Noise 1	V _{NO1}	R _g =0Ω, Volume=0dB, A-Weight	-	-117 (1.41μ)	-104 (6.3μ)	dBV (V _{rms})
Output Noise 2	V _{NO2}	R _g =0Ω, Volume=-95dB, A-Weight	-	-117 (1.41μ)	-104 (6.3μ)	dBV (V _{rms})
Total Harmonic Distortion 1	T.H.D. 1	f=1kHz, V _{IN} =1V _{rms} , Volume=0dB, BW=400Hz to 30kHz	-	0.0004	0.01	%
Total Harmonic Distortion 2	T.H.D. 2	f=10kHz, V _{IN} =1V _{rms} , Volume=0dB, BW=400Hz to 30kHz	-	0.0006	-	%
Cross Talk 1	CT1	R _g =0Ω, f=1kHz, V _{IN} =2V _{rms} , Volume=0dB, Bandpass	-	-120	-	dB
Cross Talk 2	CT2	R _g =0Ω, f=20kHz, V _{IN} =2V _{rms} , Volume=0dB, Bandpass	-	-100	-	dB
Channel Separation 1	CS1	R _g =0Ω, f=1kHz, V _{IN} =2V _{rms} , Volume=0dB, Bandpass	-	-110	-90	dB
Channel Separation 2	CS2	R _g =0Ω, f=20kHz, V _{IN} =2V _{rms} , Volume=0dB, Bandpass	-	-90	-	dB

NJU72343

■ LOGIC CONTROL CHARACTERISTICS (Ta=25°C unless otherwise specified)

◆ LOGIC CONTROL TERMINAL CHARACTERISTICS

PARAMETER	SYMBOL	TEST CONDITION	MIN.	TYP.	MAX.	UNIT
High Level Input Voltage 1	V _{IH1}	ADR, MUTE terminal	2.5	-	V ⁺	V
Low Level Input Voltage 1	V _{IL1}	ADR, MUTE terminal	0	-	0.8	V
High Level Input Voltage 2	V _{IH2}	DATA, CLOCK terminal	2.5	-	5.5	V
Low Level Input Voltage 2	V _{IL2}	DATA, CLOCK terminal	0	-	0.8	V

■ TEST CIRCUIT

◆ I_{DD}/I_{SS}

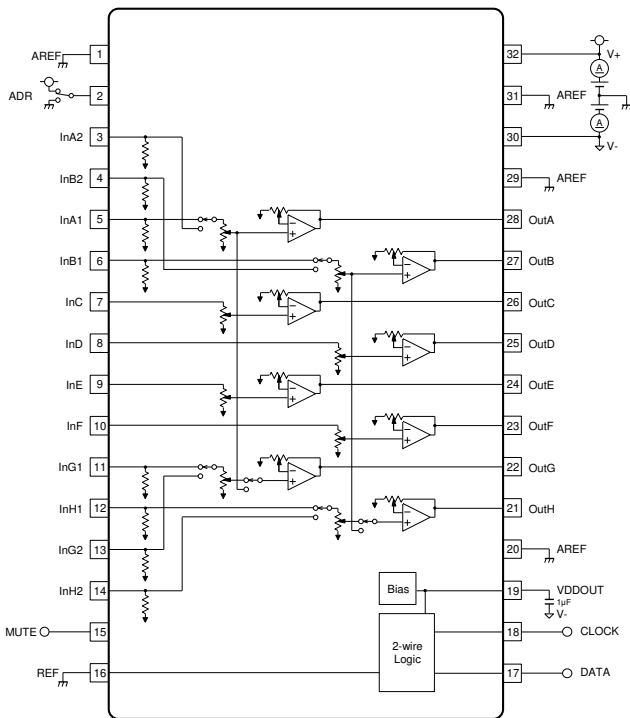

◆ V_{NO}

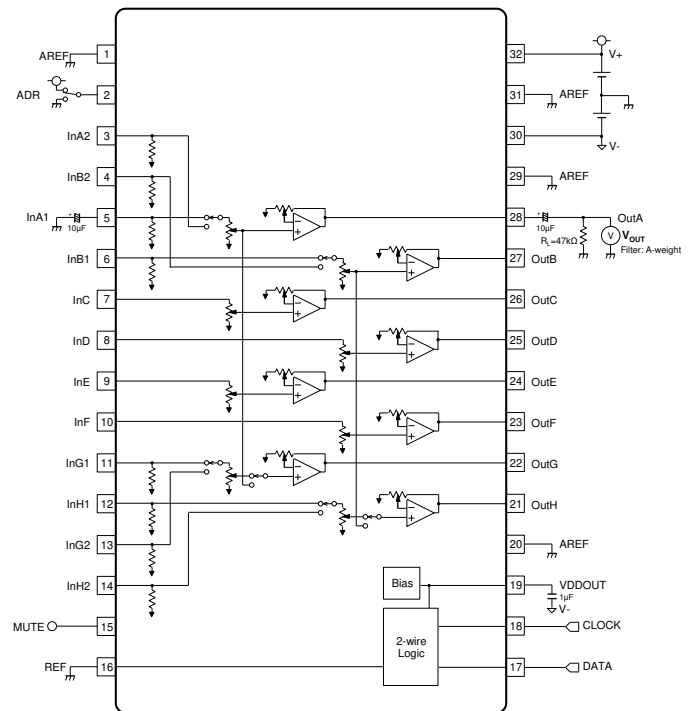

◆ THD

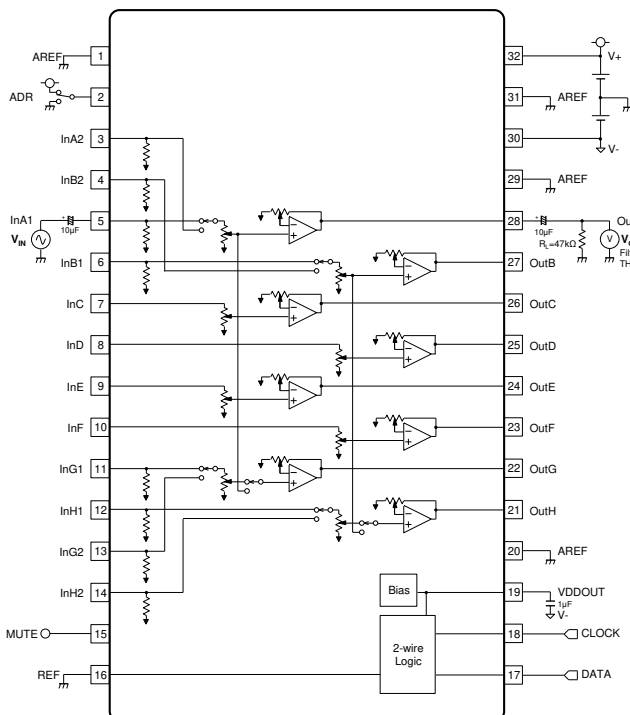

◆ CT/CS

CT Ex) InA1=ON, Input=InA2 -> Measure=OutA
 InB1=ON, Input=InB2 -> Measure=OutB

CS Ex) InA1=ON, Input=InB1 -> Measure=OutA
 InB1=ON, Input=InA1 -> Measure=OutB

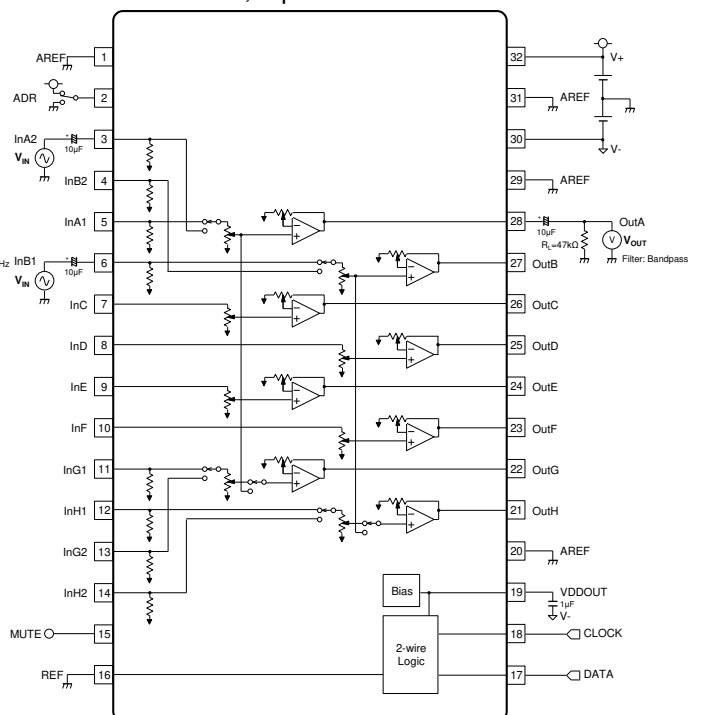

NJU72343

■ APPLICATION CIRCUIT 1 (Dual power supply operation)

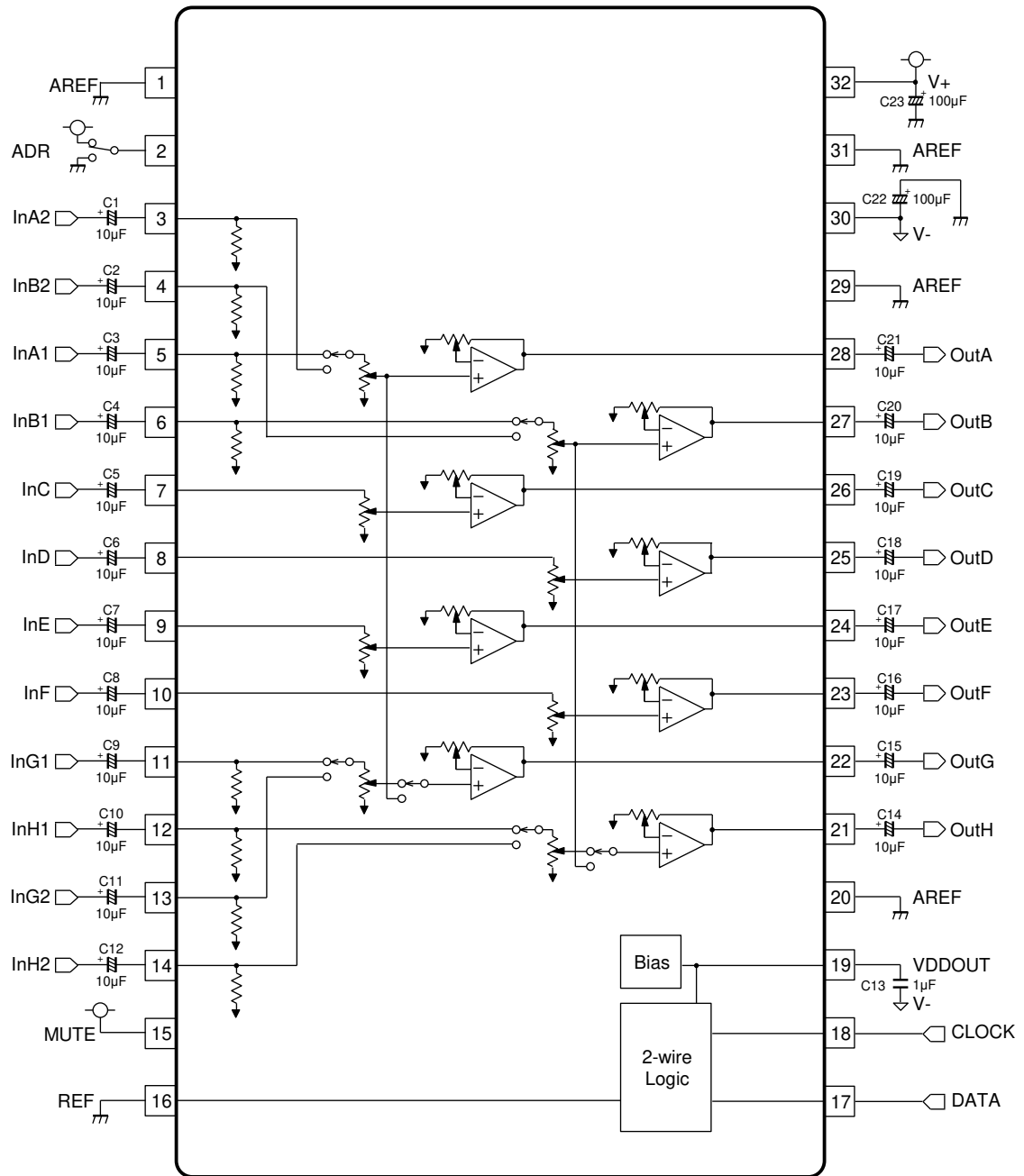

■ APPLICATION CIRCUIT 2 (Single power supply operation)

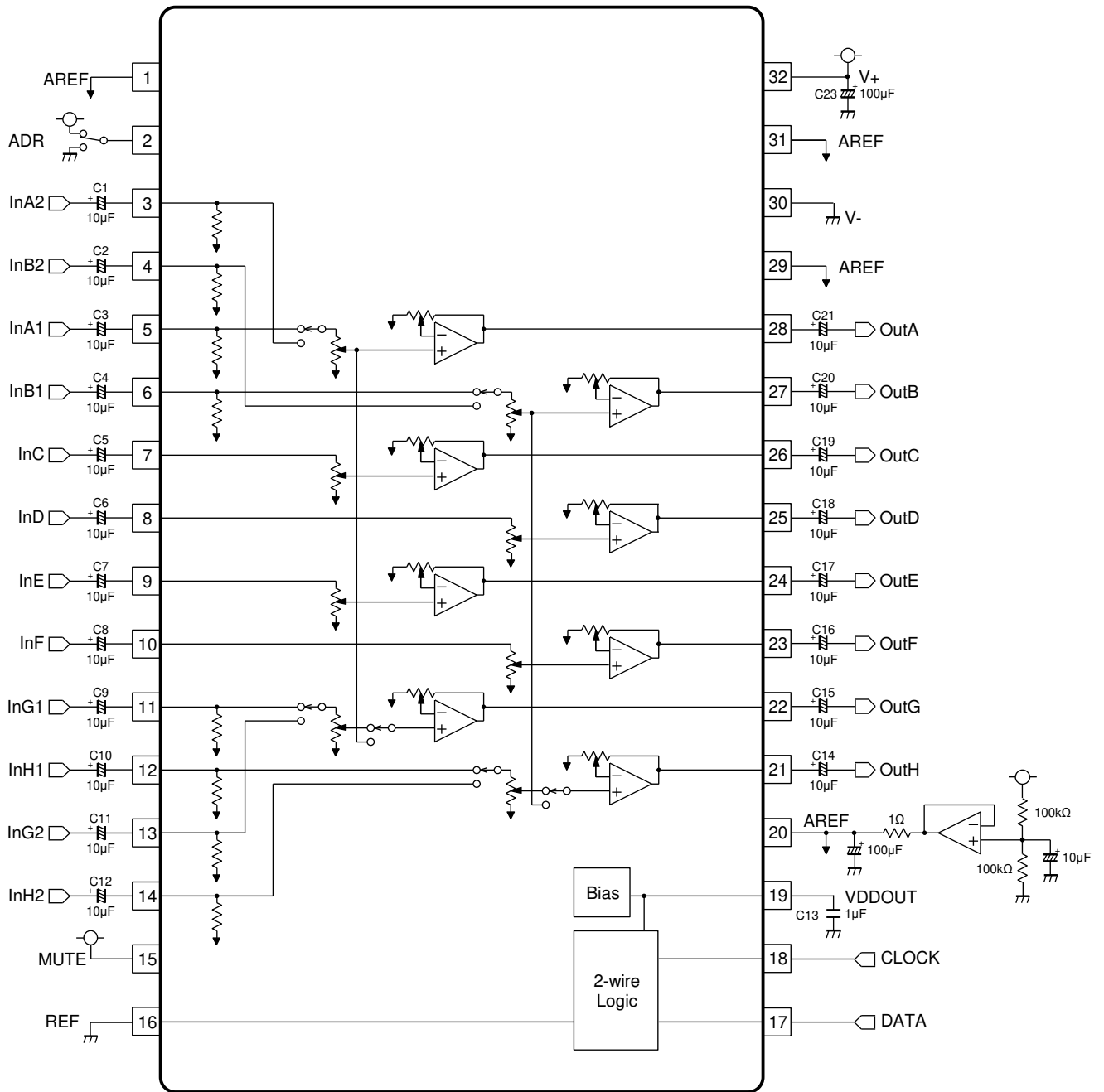

■TIMING ON 2-wire BUS (DATA, CLOCK)

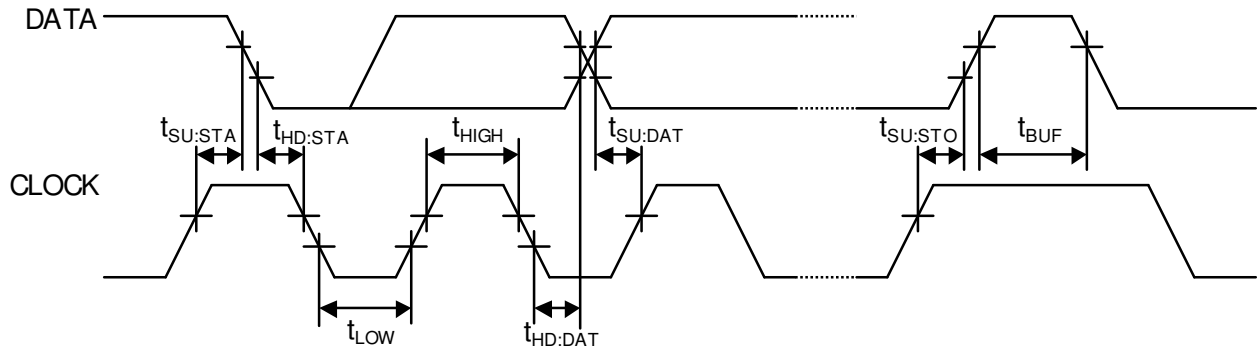

■CHARACTERISTICS OF I/O STAGES FOR 2-wire BUS (DATA, CLOCK)

PARAMETER	SYMBOL	MIN.	TYP.	MAX.	UNIT
$t_{HD:STA}$	Hold time (repeated) START condition.	4	-	-	μs
t_{LOW}	Low period of the CLOCK clock	2	-	-	μs
t_{HIGH}	High period of the CLOCK clock	2	-	-	μs
$t_{SU:STA}$	Set-up time for a repeated START condition	2	-	-	μs
$t_{HD:DAT}$	Data hold time	1	-	-	μs
$t_{SU:DAT}$	Data set-up time	1	-	-	μs
$t_{SU:STO}$	Set-up time for STOP condition	2	-	-	μs
t_{BUF}	Bus free time between a STOP and START condition	4	-	-	μs

■RECOMMENDED POWER-UP SEQUENCE

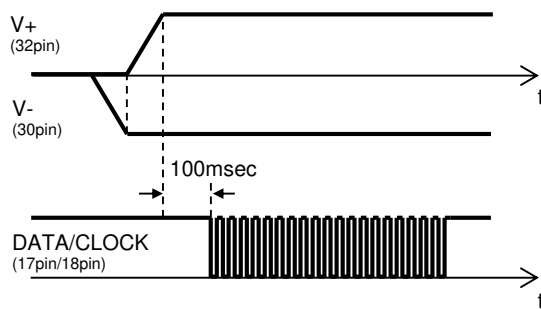

■ DEFINITION OF 2-wire REGISTER

◆ 2-wire BUS FORMAT

	MSB		LSB	MSB	LSB		LSB		
S	Chip Address		1	Select Address		1	Data	1	P
1bit	8bit		1bit	8bit		1bit	8bit	1bit	1bit

S: Starting Term
P: Ending Term

◆ Chip Address

MSB						LSB		
1	0	0	0	0	0	ADR	0	
1	0	0	0	0	0	0	0	80H (ADR = Low)
1	0	0	0	0	0	1	0	82H (ADR = High)

◆ Select Address

The select address sets each function (Volume, Hard Mute, Selector, Other Settings).

The auto increment function cycles the select address as follows.

00H→01H→02H→03H→04H→05H→06H→07H→08H→09H→00H

Select Address	Data							
	D7	D6	D5	D4	D3	D2	D1	D0
00H	Ach Volume							
01H	Bch Volume							
02H	Cch Volume							
03H	Dch Volume							
04H	Ech Volume							
05H	Fch Volume							
06H	Gch Volume							
07H	Hch Volume							
08H	Ach HM EN	Bch HM EN	Cch HM EN	Dch HM EN	Ech HM EN	Fch HM EN	Gch HM EN	Hch HM EN
09H	Ach Selector	Bch Selector	Gch Selector	Gch Assignment	Hch Selector	Hch Assignment	Don't Care	Z/C

◆ Hardware Mute

The mute function can be controlled externally. If the Mute control terminal (15pin) is switched to Low, Multi-Channel outputs are muted immediately.

External mute control terminal (MUTE: 15pin)	Setting
Low	Mute
High	Mute Cancellation

NJU72343

■ INITIAL CONDITION

Select Address	Data							
	D7	D6	D5	D4	D3	D2	D1	D0
00H	0	0	0	0	0	0	0	0
01H	0	0	0	0	0	0	0	0
02H	0	0	0	0	0	0	0	0
03H	0	0	0	0	0	0	0	0
04H	0	0	0	0	0	0	0	0
05H	0	0	0	0	0	0	0	0
06H	0	0	0	0	0	0	0	0
07H	0	0	0	0	0	0	0	0
08H	0	0	0	0	0	0	0	0
09H	0	0	0	0	0	0	0	0

Note.) This product starts up by MUTE setting in power "ON". Use it after removing MUTE of each setting.

If any audio signal is inputted in input signal terminal before power "ON", it may cause initial condition abnormality.

In conditions of use such as the above, it prevents that abnormality by setting MUTE before power "OFF"

■ DEFINITION OF RESISTOR

◆ **Volume:** +31.5 to -95dB / 0.5dB step. Each volume is controlled independently.

Select Address	Data							MSB	LSB
	D7	D6	D5	D4	D3	D2	D1		
00H	Ach Volume								
01H	Bch Volume								
02H	Cch Volume								
03H	Dch Volume								
04H	Ech Volume								
05H	Fch Volume								
06H	Gch Volume								
07H	Hch Volume								

< Volume Control Data >

Data								Setting
D7	D6	D5	D4	D3	D2	D1	D0	
0	0	0	0	0	0	0	0	Mute ^(*)
0	0	0	0	0	0	0	1	+31.5dB
0	0	0	0	0	0	1	0	+31.0dB
0	0	0	0	0	0	1	1	+30.5dB
0	0	0	0	0	1	0	0	+30.0dB
0	0	0	0	0	1	0	1	+29.5dB
0	0	0	0	0	1	1	0	+29.0dB
0	0	0	0	0	1	1	1	+28.5dB
0	0	0	0	1	0	0	0	+28.0dB
...								...
0	0	1	1	1	0	0	0	+4.0dB
0	0	1	1	1	0	0	1	+3.5dB
0	0	1	1	1	0	1	0	+3.0dB
0	0	1	1	1	0	1	1	+2.5dB
0	0	1	1	1	1	0	0	+2.0dB
0	0	1	1	1	1	0	1	+1.5dB
0	0	1	1	1	1	1	0	+1.0dB
0	0	1	1	1	1	1	1	+0.5dB
0	1	0	0	0	0	0	0	0dB
0	1	0	0	0	0	0	1	-0.5dB
0	1	0	0	0	0	1	0	-1.0dB
0	1	0	0	0	0	1	1	-1.5dB
0	1	0	0	0	1	0	0	-2.0dB
0	1	0	0	0	1	0	1	-2.5dB
0	1	0	0	0	1	1	0	-3.0dB
0	1	0	0	0	1	1	1	-3.5dB
0	1	0	0	1	0	0	0	-4.0dB
...								...
1	1	1	1	0	0	1	0	-89.0dB
1	1	1	1	0	0	1	1	-89.5dB
1	1	1	1	0	1	0	0	-90.0dB
1	1	1	1	0	1	0	1	-90.5dB
1	1	1	1	0	1	1	0	-91.0dB
1	1	1	1	0	1	1	1	-91.5dB
1	1	1	1	1	0	0	0	-92.0dB
1	1	1	1	1	0	0	1	-92.5dB
1	1	1	1	1	0	1	0	-93.0dB
1	1	1	1	1	0	1	1	-93.5dB
1	1	1	1	1	1	0	0	-94.0dB
1	1	1	1	1	1	0	1	-94.5dB
1	1	1	1	1	1	1	0	-95.0dB
1	1	1	1	1	1	1	1	Mute

^(*)Initial Setting

NJU72343

- ◆**Ach HM EN**: Select “Ach Hard Mute Enable” or “Ach Hard Mute Disable”, when the Mute control terminal (15pin) is switched to Low.
- ◆**Bch HM EN**: Select “Bch Hard Mute Enable” or “Bch Hard Mute Disable”, when the Mute control terminal (15pin) is switched to Low.
- ◆**Cch HM EN**: Select “Cch Hard Mute Enable” or “Cch Hard Mute Disable”, when the Mute control terminal (15pin) is switched to Low.
- ◆**Dch HM EN**: Select “Dch Hard Mute Enable” or “Dch Hard Mute Disable”, when the Mute control terminal (15pin) is switched to Low.
- ◆**Ech HM EN**: Select “Ech Hard Mute Enable” or “Ech Hard Mute Disable”, when the Mute control terminal (15pin) is switched to Low.
- ◆**Fch HM EN**: Select “Fch Hard Mute Enable” or “Fch Hard Mute Disable”, when the Mute control terminal (15pin) is switched to Low.
- ◆**Gch HM EN**: Select “Gch Hard Mute Enable” or “Gch Hard Mute Disable”, when the Mute control terminal (15pin) is switched to Low.
- ◆**Hch HM EN**: Select “Hch Hard Mute Enable” or “Hch Hard Mute Disable”, when the Mute control terminal (15pin) is switched to Low.

Select Address	Data							
	D7	D6	D5	D4	D3	D2	D1	D0
08H	Ach HM EN	Bch HM EN	Cch HM EN	Dch HM EN	Ech HM EN	Fch HM EN	Gch HM EN	Hch HM EN

<Hard Mute Enable Setting>

Data	Setting
D7 ~ D0	
0	Hard Mute Enable ^(*)
1	Hard Mute Disable

^(*)Initial Setting

- ◆**Ach Selector:** Ach Input Selector Data
- ◆**Bch Selector:** Bch Input Selector Data
- ◆**Gch Selector:** Gch Input Selector Data
- ◆**Gch Assignment:** Assign "Gch Input Signal" or "Ach Input Signal" to Gch Output.
- ◆**Hch Selector:** Hch Input Selector Data
- ◆**Hch Assignment:** Assign "Hch Input Signal" or "Bch Input Signal" to Hch Output.
- ◆**Z/C:** Zero Cross Detection circuit ON/OFF setting

Select Address	MSB								LSB
	Data								
	D7	D6	D5	D4	D3	D2	D1	D0	
09H	Ach Selector	Bch Selector	Gch Selector	Gch Assignment	Hch Selector	Hch Assignment	Don't Care	Z/C	

<Ach Selector Setting>

Data	Setting
D7	
0	Ach Input 1 ^(*)
1	Ach Input 2

<Bch Selector Setting>

Data	Setting
D6	
0	Bch Input 1 ^(*)
1	Bch Input 2

<Gch Selector Setting>

Data	Setting
D5	
0	Gch Input 1 ^(*)
1	Gch Input 2

<Gch Assignment Setting>

Data	Setting
D4	
0	InG1/InG2 Input ^(*)
1	InA1/InA2 Input

<Hch Selector Setting>

Data	Setting
D3	
0	Hch Input 1 ^(*)
1	Hch Input 2

<Hch Assignment Setting>

Data	Setting
D2	
0	InH1/InH2 Input ^(*)
1	InB1/InB2 Input

<Z/C Setting>

Data	Setting
D0	
0	Zero Cross OFF ^(*)
1	Zero Cross ON

^(*)Initial Setting

■ TYPICAL CHARACTERISTICS

Supply Current 1 vs Supply Voltage
No signal

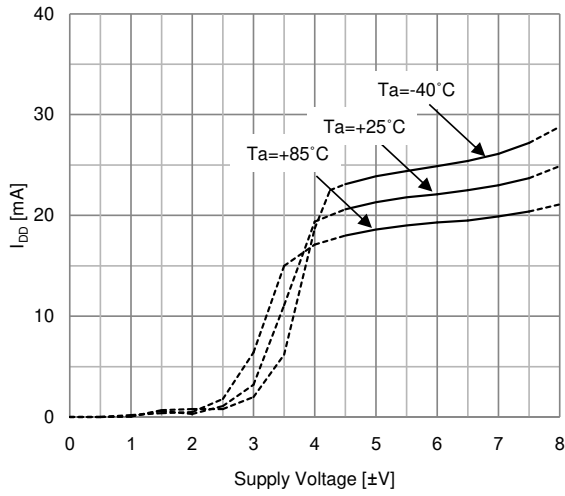

Supply Current 2 vs Supply Voltage
No signal

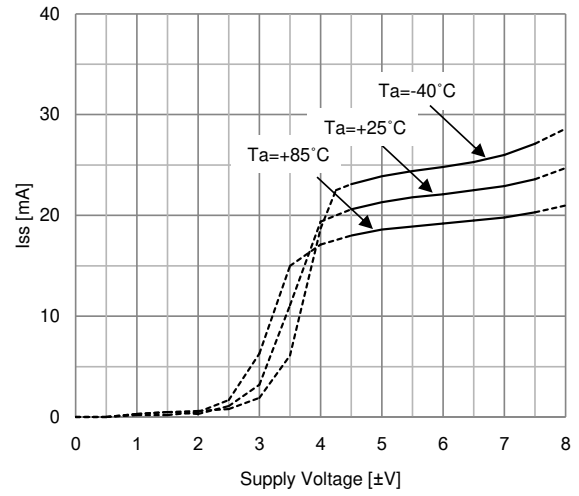

Maximum Output Voltage vs Supply Voltage
f=1kHz, THD=1%, I/O: InA1-OutA

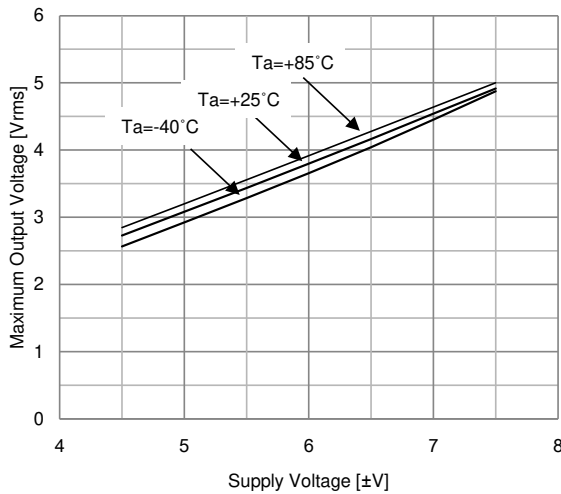

Output Voltage vs Load Resistance
V=±7V, f=1kHz, Vin=4.2Vrms

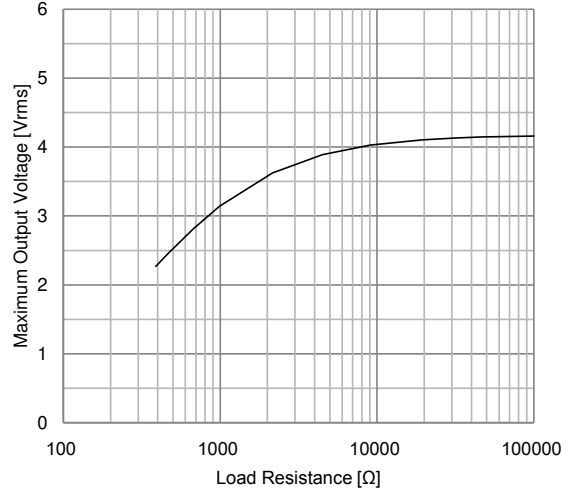

Output Voltage Gain vs Frequency

V=±7V, Vin=2Vrms (VOL=0, -60, -95dB, Mute),
Vin=0.1Vrms (VOL=+15, +30dB), Bandpass

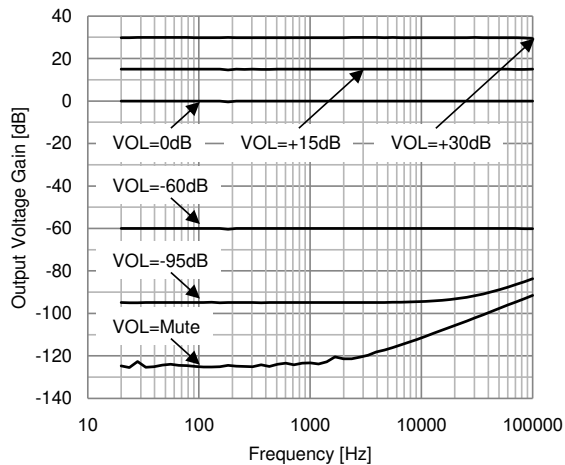

Output Voltage Gain vs Volume Setting

V=±7V, f=1kHz, Vin=2Vrms (VOL=0, -60, -95dB, Mute),
Vin=0.1Vrms (VOL=+15, +30dB), BW: 400Hz-30kHz

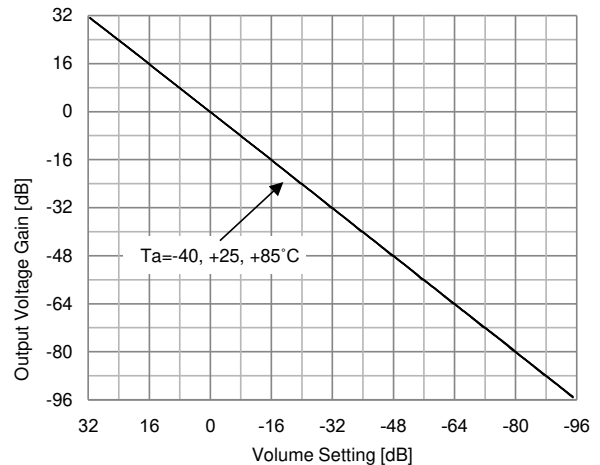

■ TYPICAL CHARACTERISTICS

THD+N vs Input Voltage

$V = \pm 7V$, BW: 22Hz to 30kHz, I/O=InA1-OutA

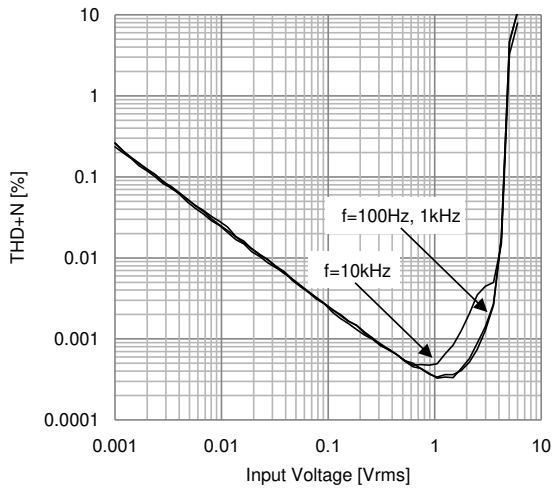

THD+N vs Input Voltage

$V = \pm 7V$, BW: 22Hz-30kHz, I/O=InC-OutC

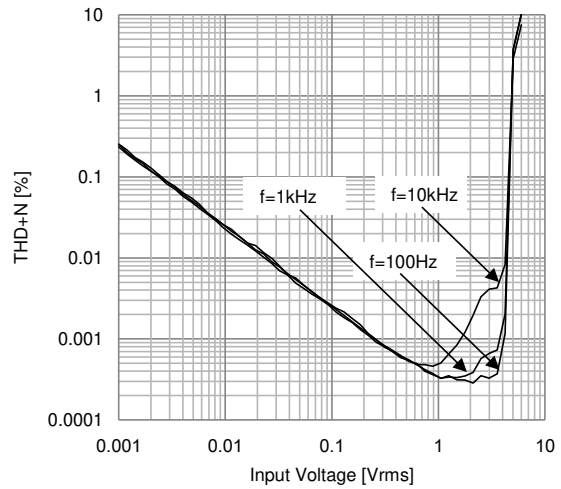

THD+N vs Input Voltage

$V = \pm 7V$, $f = 1kHz$, BW: 400Hz-30kHz, I/O=InA1-OutA

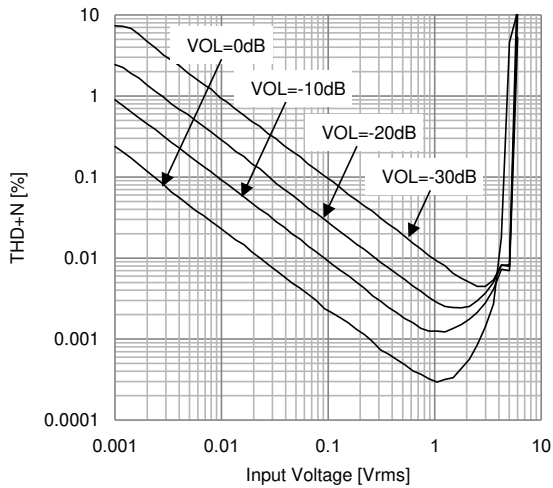

THD+N vs Input Voltage

$V = \pm 7V$, $f = 1kHz$, BW: 400Hz-30kHz, I/O=InC-OutC

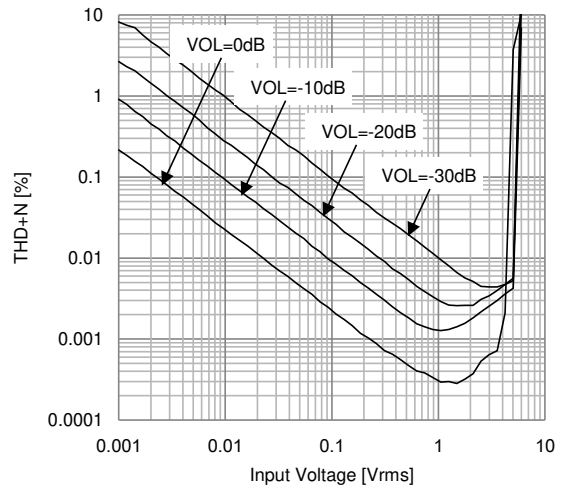

THD+N vs Frequency

$V = \pm 7V$, BW: 22Hz-80kHz, I/O=InA1-OutA

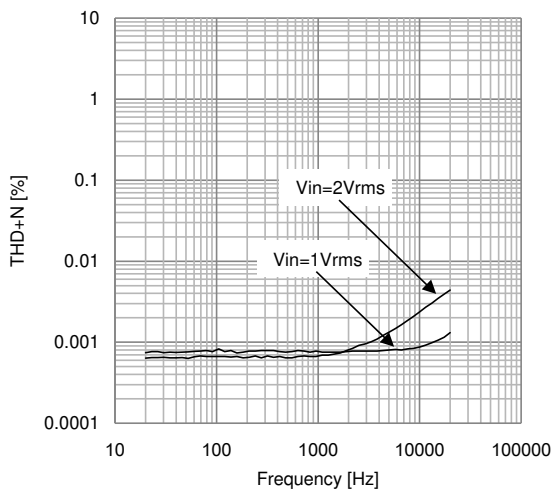

THD+N vs Frequency

$V = \pm 7V$, BW: 22Hz-80kHz, I/O=InC-OutC

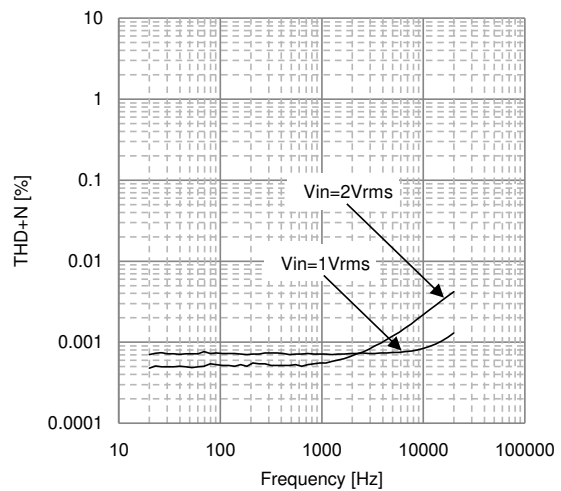

■ TYPICAL CHARACTERISTICS

THD+N vs Input Voltage

$V = \pm 7V$, $f = 1kHz$, BW: 22Hz-30kHz, I/O=InA1-OutA

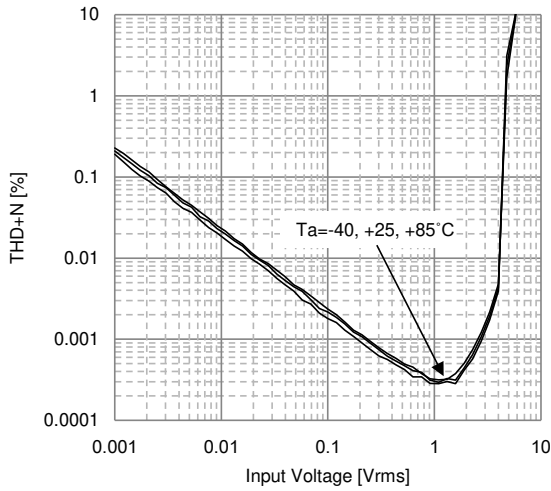

THD+N vs Frequency

$V = \pm 7V$, $V_{in} = 1V_{rms}$, BW: 22Hz-80kHz, I/O=InA1-OutA

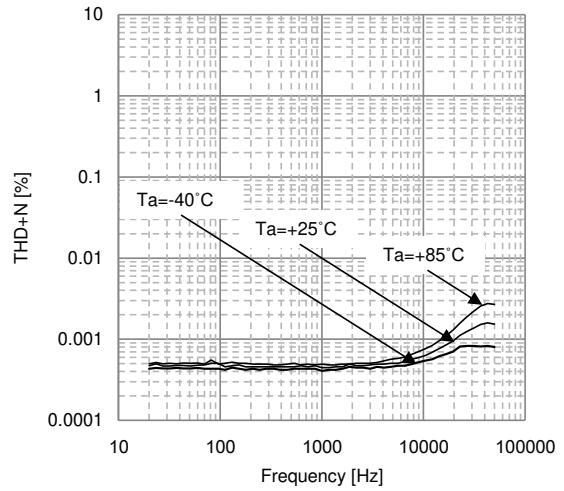

Cross Talk vs Frequency

$V = \pm 7V$, $V_{in} = 2V_{rms}$, BW: Bandpass, I/O=InA1-OutA, $R_g = InA2$, Select Channel=InA2

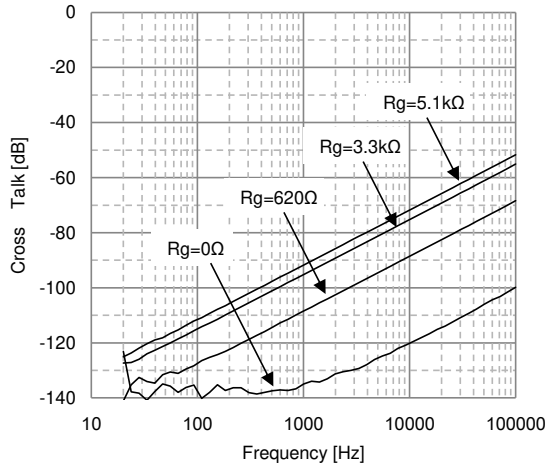

Channel Separation vs Frequency

$V = \pm 7V$, $V_{in} = 2V_{rms}$, BW: Bandpass, I/O=InB1-OutA, $R_g = InA1$, Select Channel=InA1

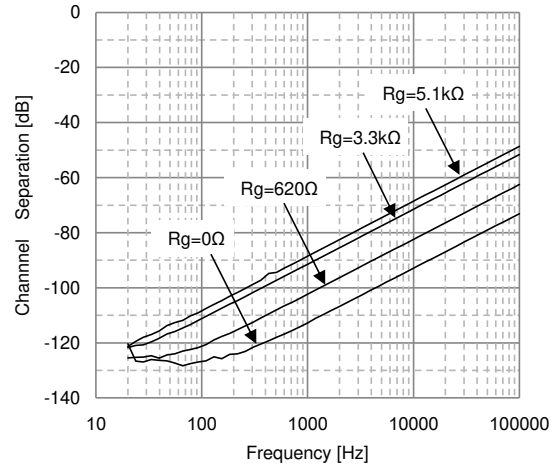

[CAUTION]
 The specifications on this databook are only given for information, without any guarantee as regards either mistakes or omissions. The application circuits in this databook are described only to show representative usages of the product and not intended for the guarantee or permission of any right including the industrial rights.