

AI-TWIN 2X 6 -14 GN - Ferrule

1213205

<https://www.phoenixcontact.com/us/products/1213205>

Please be informed that the data shown in this PDF document is generated from our online catalog. Please find the complete data in the user documentation. Our general terms of use for downloads are valid.

Ferrule, sleeve length: 14 mm, length: 25 mm, color: green



Your advantages

- These special ferrules allow chain bridges to be set up with ease
- The TWIN ferrules provide a practical way of crimping two conductors in one ferrule
- Different versions of the individual TWIN ferrules can be selected for specific applications

Commercial data

Item number	1213205
Packing unit	1 pc
Minimum order quantity	100 pc
Sales key	BH34
Product key	BH3413
Catalog page	Page 486 (C-3-2019)
GTIN	4055626280851
Weight per piece (including packing)	0.718 g
Weight per piece (excluding packing)	0.671 g
Customs tariff number	85369010
Country of origin	DE

1213205

<https://www.phoenixcontact.com/us/products/1213205>

Technical data

Product properties

Product type	Cable end sleeve
Conductor category	stranded conductors, class 2, 5, 6 / B, C, K, M

Connection data

Conductor connection

Conductor cross section flexible max.	6 mm ²
Conductor cross section AWG max.	10
Stripping length	19 mm

Dimensions

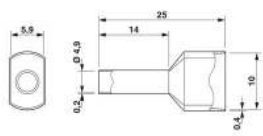
Dimensional drawing	
Length	25 mm
Sleeve length	14 mm
Maximum stripping length	19 mm
Ferrule diameter	4.9 mm
Sleeve wall thickness	0.2 mm
Insulating collar thickness	0.4 mm
Inner dimensions of the insulating collar	5.9 mm

Material specifications

Color	green
Material	CU-DHP
Flammability rating according to UL 94	HB
Coating	tin-plated (galvanic)
Components	free from silicone and halogen

Mechanical properties

Technical data

Sleeve length	14 mm
---------------	-------

Environmental and real-life conditions

Ambient conditions

Permanent temperature	105 °C (-40 °C no load / 0 °C dynamic load)
Short-term temperature	120 °C

AI-TWIN 2X 6 -14 GN - Ferrule

1213205

<https://www.phoenixcontact.com/us/products/1213205>



Standards and regulations

Design according to standard

DIN 46228-4

AI-TWIN 2X 6 -14 GN - Ferrule



1213205

<https://www.phoenixcontact.com/us/products/1213205>

Drawings

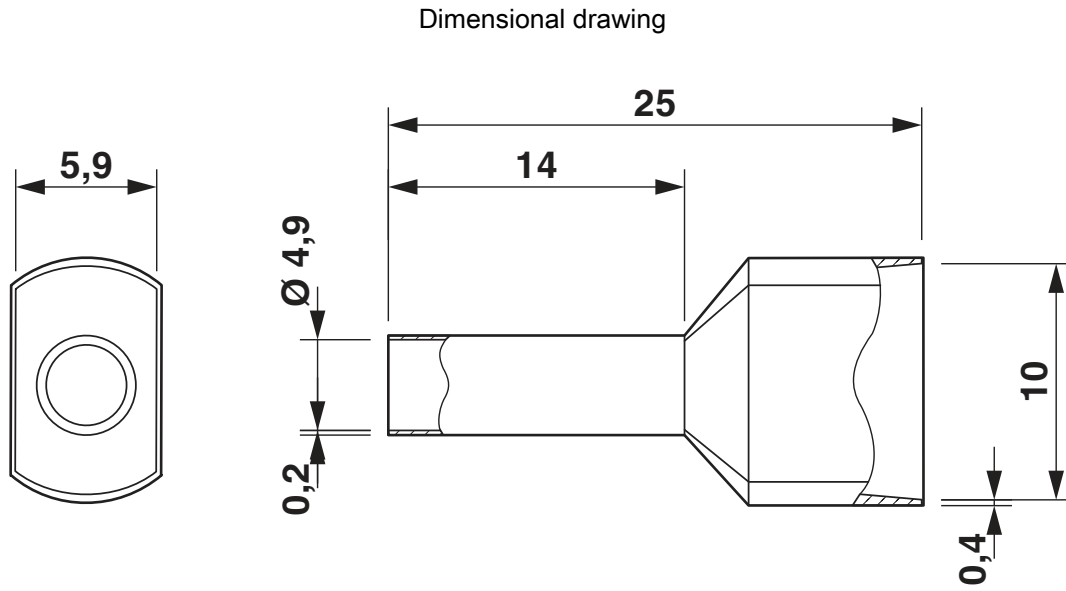

AI-TWIN 2X 6 -14 GN - Ferrule



1213205

<https://www.phoenixcontact.com/us/products/1213205>

Classifications

ECLASS

ECLASS-11.0	27400201
ECLASS-13.0	27400201
ECLASS-12.0	27400201

ETIM

ETIM 8.0	EC000005
----------	----------

UNSPSC

UNSPSC 21.0	27121700
-------------	----------

AI-TWIN 2X 6 -14 GN - Ferrule



1213205

<https://www.phoenixcontact.com/us/products/1213205>

Environmental product compliance

China RoHS	Environmentally friendly use period: unlimited = EFUP-e
	No hazardous substances above threshold values

AI-TWIN 2X 6 -14 GN - Ferrule

1213205

<https://www.phoenixcontact.com/us/products/1213205>



Accessories

CRIMPFOX 16R TWIN - Crimping pliers

1212845

<https://www.phoenixcontact.com/us/products/1212845>



Crimping pliers, for TWIN ferrules according to UL 486F, three marked die stations, unlockable pressure lock, lateral entry

Phoenix Contact 2023 © - all rights reserved
<https://www.phoenixcontact.com>

Phoenix Contact USA
586 Fulling Mill Road
Middletown, PA 17057, United States
(+717) 944-1300
info@phoenixcon.com