



# GS2B, GS2BL MS90387-1 GS2B-CR

## GS2B-CR MAINTENANCE ONLY

Occasionally lubricate pivot and sliding surfaces as indicated, with Dow #7 compound, light consistency.

- \* Lubrication locations (remove cover as needed)

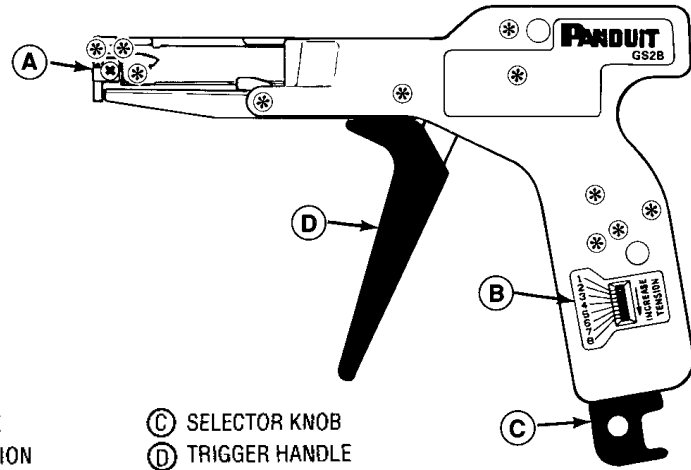

- A NOSE
- B TENSION INDICATOR
- C SELECTOR KNOB
- D TRIGGER HANDLE

## OPERATING INSTRUCTIONS

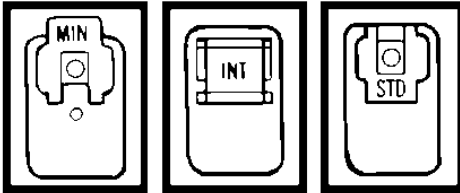

1. Reading the selector knob from the bottom of tool, flip knob to correct position for cross-section of cable ties being installed.  
MIN.: .10" (2.5mm) WIDE CABLE TIES  
INT.: .14" (3.6mm) WIDE CABLE TIES  
STD.: .19" (4.8mm) WIDE CABLE TIES

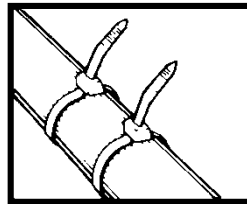

2. Loop cable tie around bundle with head out and insert tip through head. Pull tie up snug on bundle by hand.

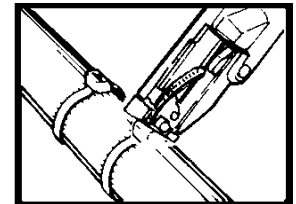

3. Insert tail of cable tie into tool (as shown). With nose of tool flush to cable tie head, squeeze trigger handle. Tool will tighten cable tie and cut off excess.

## ADJUSTMENT INSTRUCTIONS

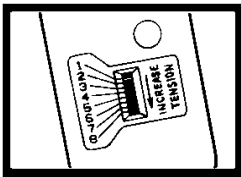

1. There is a TENSION INDICATOR on the tool. Suggested tension settings are:  
No. 3 for MIN.  
No. 5 for INT.  
No. 8 for STD.

These are factory set for maximum tension.

- \* No. 1 for .6SM/.7M

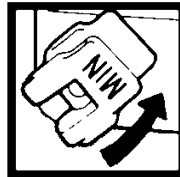

2. To DECREASE TENSION, turn knob counter clockwise.

## TOOL MAINTENANCE GS2B, GS2BL

These tools require no special operator maintenance.

## REPLACEMENT KITS AND ACCESSORIES

**Blade Replacement Kit: K2-BLD2**  
**Tension Locking Kit: TTLK3**  
(see next page for instructions)