

REV.	DESCRIPTION	DATE	APPROVED
B	Engineering Update w/o Changes	02/27/04	M. C.
C	Removed Material Code	05/28/16	J. C.

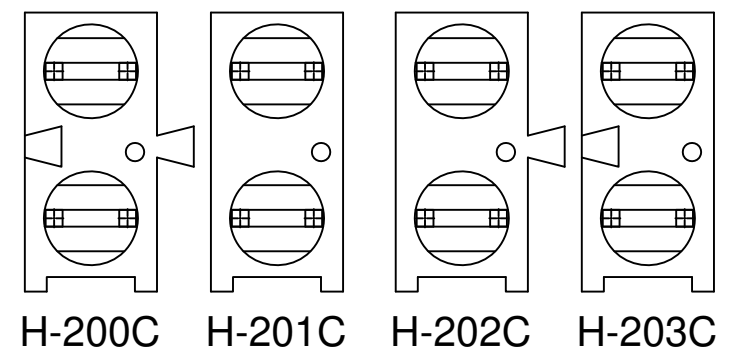
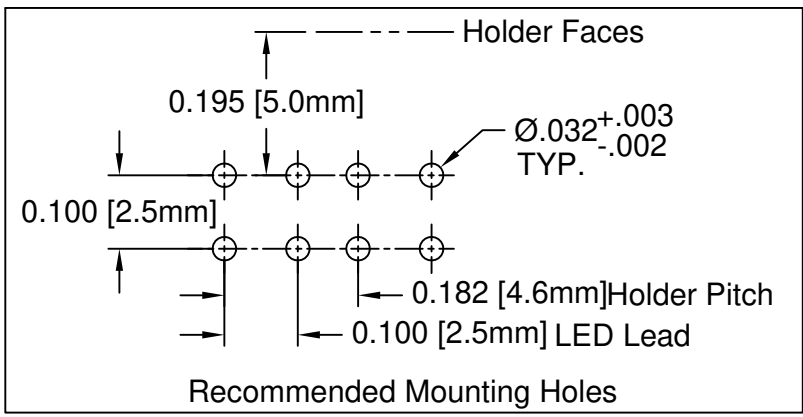
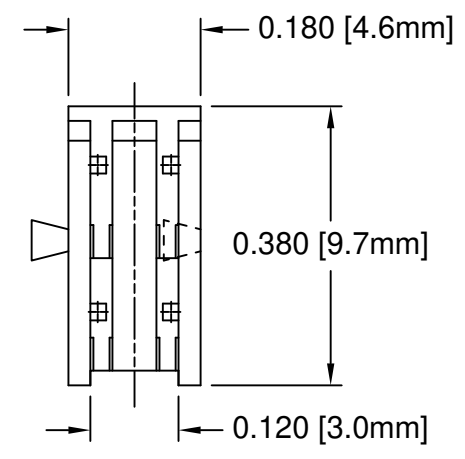
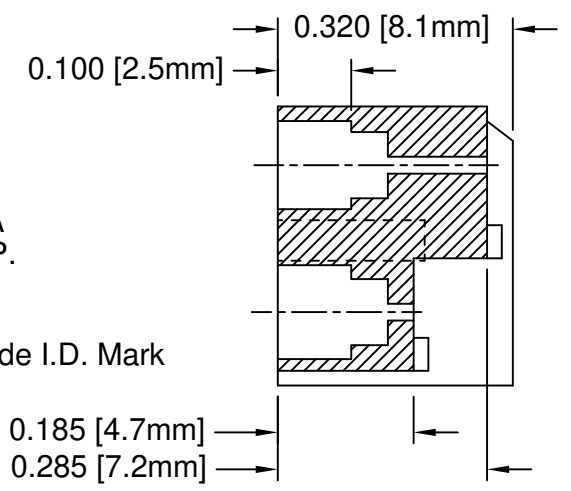
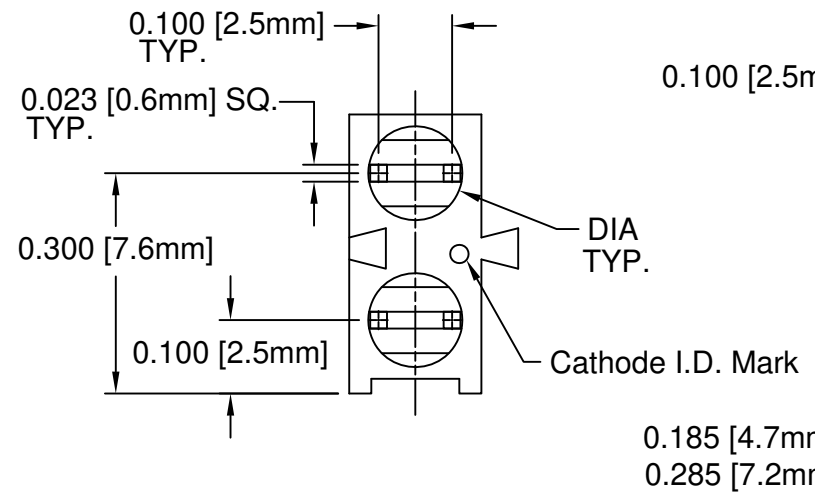

PART NO.				DIA
H-200C SERIES	H-201C SERIES	H-202C SERIES	H-203C SERIES	
H-200C	H-201C	H-202C	H-203C	.128 [3.3mm]
H-200C-1	H-201C-1	H-202C-1	H-203C-1	.150 [3.8mm]

STANDARD TOLERANCE (UNLESS OTHERWISE SPECIFIED)	
DECIMALS	ANGULAR
.X ± .1	X° ± 1°
.XX ± .01	
.XXX ± .005	

BIVAR[®]
 4 THOMAS, IRVINE, CA. 92618
 TEL: (949) 951-8808 FAX: (949) 951-3974

TITLE: BI-LEVEL T-1 (3mm) LED HOLDER
 INTERLOCKING VARIABLE DIAMETER

DESIGNED: D. Green **DATE:** 03/13/03 **PART NO:** H-20XC-X **REVISION:** C

CHECKED: M. Chen **DATE:** 03/13/03 **CAGE CODE :** 32559 **SHEET #** 1 **OF** 1

CAD GENERATED DOCUMENT. DO NOT MEASURE DRAWING.

2. MATERIAL: NYLON 6/6, 94V-0, BLACK.
1. GENERAL SPECIFICATIONS: BIVAR MOLDED COMPONENT SPECIFICATION BV00-E101.