

PART NUMBER	REV	FIRST USED
567274-1	B	122500-1
567274-2	B	565435-5

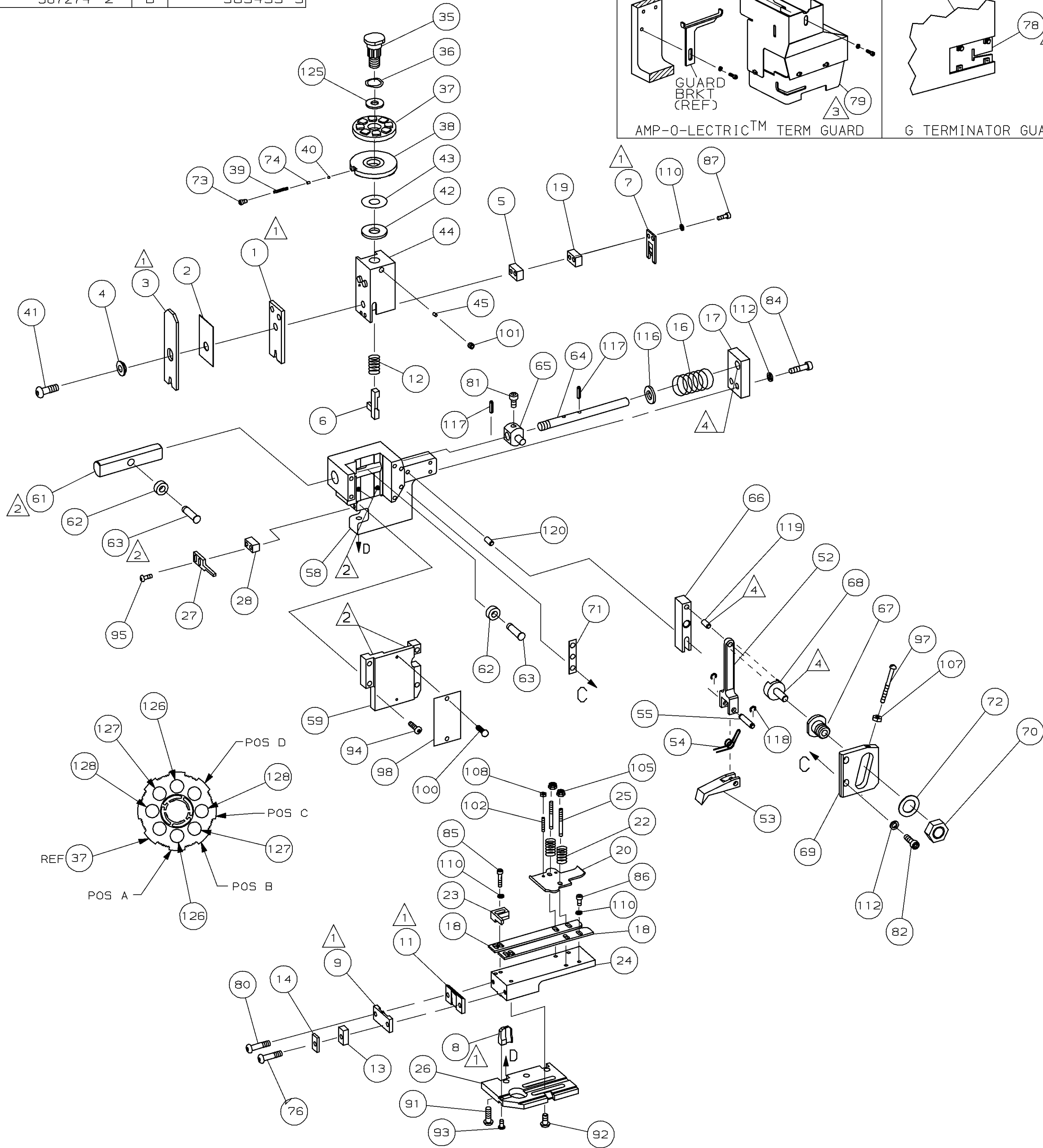
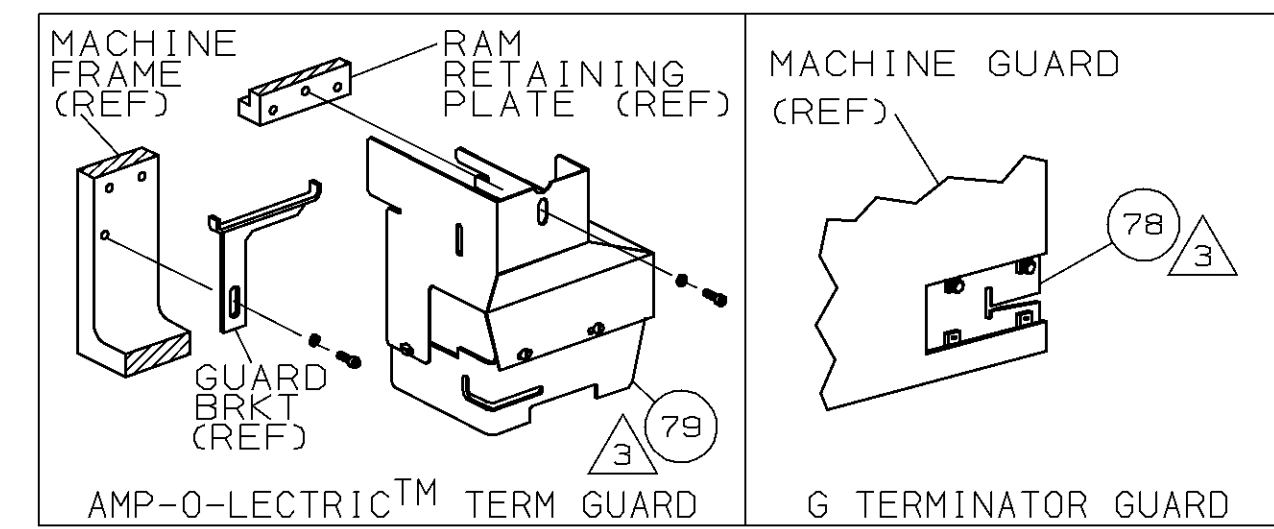

TERMINAL NAME: MIC MKII TAB					
CRIMPING DATA					
PAD LTR	CRIMP HEIGHT			WIRE SIZE	
	A	.055 ±.002 [1.40 ±0.05mm]		18	
	B	.050 ±.002 [1.27 ±0.05mm]		20	
	C	.046 ±.002 [1.17 ±0.05mm]		22	
D	NOT USED			USED	
CRIMP	SIZE	TYPE	RANGE		
WIRE	.070 [1.78mm]	F	22-18		
INSUL	.130 [3.30mm]	F	.059-.102		
WIRE STRIP LENGTH	TERM APPL SPEC	FEED	APPL INSTRUCTION	SET UP GAGE	LAYOUT
.118-.157	114-5072	1.106	408-8039	458638-1	L1300

-1	LEADMAKER & BENCH MODEL G	MECH POST FEED	ITEM NO			
-2	BENCH MODEL K	MECH PRE FEED	ITEM NO			
REF	REF	A	22594-8 NUT, HEX 70			
REF	REF	B	240628-1 PLATE, ADJ 69			
REF	REF	B	240626-1 SHAFT, PIVOT 68			
REF	REF	B	240633-1 BUSHING 67			
REF	REF	A	455680-1 LEVER, INTERMEDIATE 66			
REF	REF	B	240629-1 BLOCK, PIVOT 65			
REF	REF	A	240632-2 SCR, ADJ 64			
REF	REF	B	240659-3 PIN, CAM ROLLER 63			
REF	REF	B	240658-1 CAM, ROLLER 62			
REF	REF	B	454398-1 ROD, FEED 61			
REF	REF	C	454220-1 CAP, RAM 60			
REF	REF	D	453736-1 HOUSING 59			
REF	REF	B	240624-1 PIN, FEED FINGER 55			
REF	REF	B	691499-1 SPRING, FEED FINGER 54			
REF	REF	B	240635-1 FINGER, FEED 53			
REF	REF	B	240634-1 LEVER, TERMINAL 52			
REF	REF	A	1-21030-7 PIN, DOWEL (Ø.187x1.50)HSG 120			
REF	REF	A	1-21030-1 PIN, DOWEL (Ø.187x.50)LEVER 119			
REF	REF	A	21045-3 RING, RET "C" (Ø.187)FD PIN 118			
REF	REF	A	5-21028-1 PIN, STD SPRING (Ø.12)FD ADJ ROD 117			
REF	REF	A	21899-4 WASHER, FLAT (Ø5/16)SCR ADJ 116			
REF	REF	A	21024-5 WASHER, LOCK (NO.10)FD ROD GDE 112			
7	7	A	21024-4 WASHER, LOCK (NO.8)SHEAR BL 110			
2	2	A	21018-4 NUT, HEX (4-40)DRAG 109			
REF	REF	A	21018-5 NUT, HEX (6-32)FD ADJ PL 107			
2	2	A	21022-2 NUT, HEX SL (8-32)DRAG STUD 105			
2	2	A	2-21006-6 SCR, SKT SET (4-40x.62)DRAG 102			
1	1	A	21009-2 SCR, SKT SET (1/4-20x.25)RAM 101			
2	2	A	21017-2 SCR, DRIVE (#2x.19)ID PLATE 100			
1	1	A	1-21002-7 SCR, BHC (6-32x.38)CAM 99			
1	1	B	461264-1 PLATE, IDENTIFICATION 98			
REF	REF	A	6-23715-5 SCR, PAN HD (6-32x1.50)FEED ADJ 97			
2	2	A	2-21002-2 SCR, BHC (8-32x.50)STRIPPER 95			
REF	REF	A	2-21002-9 SCR, BHC (10-32x.75)HSG CAP 94			
1	1	A	22733-8 SCR, BHC (8-32x.38 LW)ANVIL 93			
4	4	A	3-21002-3 SCR, BHC (1/4-20x.50)ST GD PL 92			
REF	REF	A	2-22733-8 SCR, BHC (1/4-20x.62)BASE PL 91			
REF	REF	A	3-21000-0 SCR, SHC (8-32x.88)SLUG BLADE 87			
3	3	A	2-21000-6 SCR, SHC (8-32x.38)STRIP GUIDE 86			
2	2	A	2-21000-8 SCR, SHC (8-32x.62)R STRIP GUIDE 85			
REF	REF	A	3-21000-7 SCR, SHC (10-32x.75)FEED ROD GDE 84			
REF	REF	A	3-21000-6 SCR, SHC (10-32x.62)FEED ADJ PL 82			
REF	REF	A	3-21000-4 SCR, SHC (10-32x.38)PIVOT BLOCK 81			
1	1	A	3-21000-8 SCR, SHC (10-32x.88)SHEAR PL 80			
REF	REF	A	455745-1 GUARD, WINDOW 79			
REF	REF	A	679532-1 INSERT, GUARD 78			
1	1	A	4-21000-0 SCR, SHC (10-32x1.25) 76			
1	1	A	690603-1 SPRING, ASSIST 74			
1	1	A	23030-1 SCR, SKT CAP (6-32x.25)CP DSC 73			
REF	REF	A	458109-1 WASHER, FLAT (SPECIAL) 72			
REF	REF	A	690517-1 SPACER 71			
-2	-1	U/M	DWG SIZE	PART NO	DESCRIPTION	ITEM NO
QTY	REQD	PER ASSY				

THIS DRAWING IS UNPUBLISHED. RELEASED FOR PUBLICATION APR 7, 1998 BY AMP INCORPORATED. ALL INTERNATIONAL RIGHTS RESERVED. © COPYRIGHT 1998

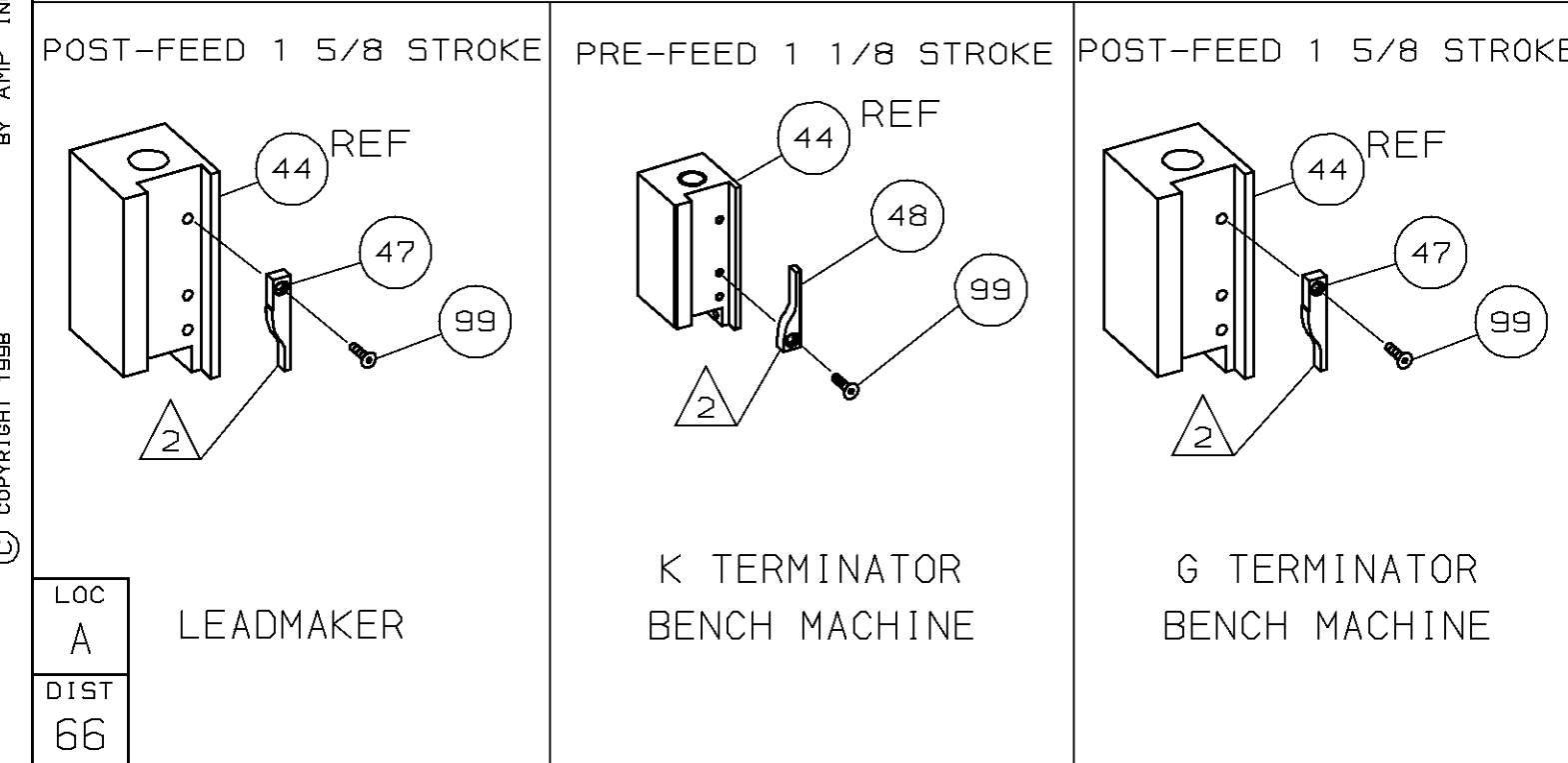

- 1 RECOMMENDED SPARE PARTS.
- 2 GREASE LIGHTLY.
- 3 GUARD MUST BE IN PLACE WHEN OPERATING APPLICATOR IN A BENCH MACHINE.
- 4 LUBRICATE DAILY USING NO. 20 MACHINE OIL.
- 5. ITEMS WITH QTY OF REF SPECIFIED (EXCEPT ITEMS 78 AND 79) ARE USED ON ITEM 32.
- 6 ITEM 78 USED WITH G TERMINATOR ONLY.