

High-Speed CMOS Logic 4x4 Register File

January 1998 - Revised October 2003

Features

- **Simultaneous and Independent Read and Write Operations**
- **Expandable to 512 Words of n-Bits**
- **Three-State Outputs**
- **Organized as 4 Words x 4 Bits Wide**
- **Buffered Inputs**
- **Typical Read Time = 16ns for 'HC670 $V_{CC} = 5V$, $C_L = 15pF$, $T_A = 25^\circ C$**
- **Fanout (Over Temperature Range)**
 - **Standard Outputs 10 LSTTL Loads**
 - **Bus Driver Outputs 15 LSTTL Loads**
- **Wide Operating Temperature Range . . . $-55^\circ C$ to $125^\circ C$**
- **Balanced Propagation Delay and Transition Times**
- **Significant Power Reduction Compared to LSTTL Logic ICs**
- **HC Types**
 - **2V to 6V Operation**
 - **High Noise Immunity: $N_{IL} = 30\%$, $N_{IH} = 30\%$ of V_{CC} at $V_{CC} = 5V$**
- **HCT Types**
 - **4.5V to 5.5V Operation**
 - **Direct LSTTL Input Logic Compatibility, $V_{IL} = 0.8V$ (Max), $V_{IH} = 2V$ (Min)**
 - **CMOS Input Compatibility, $I_I \leq 1\mu A$ at V_{OL} , V_{OH}**

Description

The 'HC670 and CD74HCT670 are 16-bit register files organized as 4 words x 4 bits each. Read and write address and enable inputs allow simultaneous writing into one location while reading another. Four data inputs are provided to store the 4-bit word. The write address inputs (WA0 and WA1) determine the location of the stored word in the register. When write enable (\overline{WE}) is low the word is entered into the address location and it remains transparent to the data. The outputs will reflect the true form of the input data. When (\overline{WE}) is high data and address inputs are inhibited. Data acquisition from the four registers is made possible by the read address inputs (RA1 and RA0). The addressed word appears at the output when the read enable (\overline{RE}) is low. The output is in the high impedance state when the (\overline{RE}) is high. Outputs can be tied together to increase the word capacity to 512 x 4 bits.

Ordering Information

| PART NUMBER | TEMP. RANGE (°C) | PACKAGE |
|---------------|------------------|--------------|
| CD54HC670F3A | -55 to 125 | 16 Ld CERDIP |
| CD74HC670E | -55 to 125 | 16 Ld PDIP |
| CD74HC670M | -55 to 125 | 16 Ld SOIC |
| CD74HC670MT | -55 to 125 | 16 Ld SOIC |
| CD74HC670M96 | -55 to 125 | 16 Ld SOIC |
| CD74HCT670E | -55 to 125 | 16 Ld PDIP |
| CD74HCT670M | -55 to 125 | 16 Ld SOIC |
| CD74HCT670MT | -55 to 125 | 16 Ld SOIC |
| CD74HCT670M96 | -55 to 125 | 16 Ld SOIC |

NOTE: When ordering, use the entire part number. The suffix 96 denotes tape and reel. The suffix T denotes a small-quantity reel of 250.

Pinout

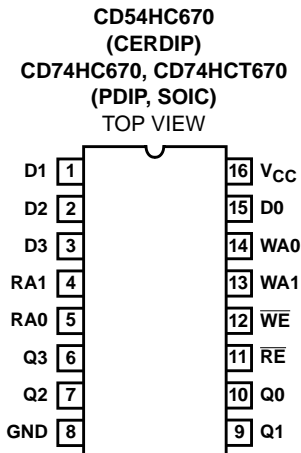

CD54HC670, CD74HC670, CD74HCT670

Functional Diagram

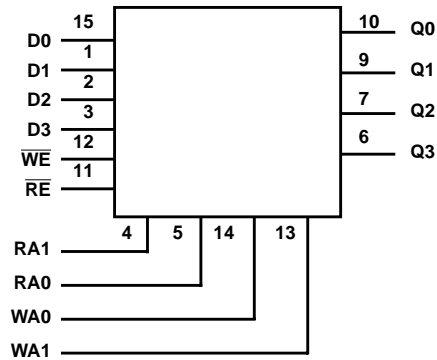

WRITE MODE SELECT TABLE

| OPERATING MODE | INPUTS | | INTERNAL LATCHES (NOTE 1) |
|----------------|-----------------|-------|---------------------------|
| | \overline{WE} | D_N | |
| Write Data | L | L | L |
| | L | H | H |
| Data Latched | H | X | No Change |

NOTE:

1. The Write Address (WA0 and WA1) to the "internal latches" must be stable while \overline{WE} is LOW for conventional operation.

READ MODE SELECT TABLE

| OPERATING MODE | INPUTS | | OUTPUT Q_N |
|----------------|-----------------|---------------------------|--------------|
| | \overline{RE} | INTERNAL LATCHES (NOTE 2) | |
| Read | L | L | L |
| | L | H | H |
| Disabled | H | X | (Z) |

NOTE:

2. The selection of the "internal latches" by Read Address (RA0 and RA1) are not constrained by \overline{WE} or \overline{RE} operation.
 H = High Voltage Level
 L = Low Voltage Level
 X = Don't Care
 Z = High Impedance "Off" State

CD54HC670, CD74HC670, CD74HCT670

Absolute Maximum Ratings

| | |
|--|-------------|
| DC Supply Voltage, V_{CC} | -0.5V to 7V |
| DC Input Diode Current, I_{IK} | |
| For $V_I < -0.5V$ or $V_I > V_{CC} + 0.5V$ | $\pm 20mA$ |
| DC Output Diode Current, I_{OK} | |
| For $V_O < -0.5V$ or $V_O > V_{CC} + 0.5V$ | $\pm 20mA$ |
| DC Drain Current, per Output, I_O | |
| For $-0.5V < V_O < V_{CC} + 0.5V$ | $\pm 35mA$ |
| DC Output Source or Sink Current per Output Pin, I_O | |
| For $V_O > -0.5V$ or $V_O < V_{CC} + 0.5V$ | $\pm 25mA$ |
| DC V_{CC} or Ground Current, I_{CC} | $\pm 50mA$ |

Thermal Information

| | |
|--|----------------------|
| Thermal Resistance (Typical, Note 3) | θ_{JA} (°C/W) |
| E (PDIP) Package | 67 |
| M (SOIC) Package | 73 |
| Maximum Junction Temperature | 150°C |
| Maximum Storage Temperature Range | -65°C to 150°C |
| Maximum Lead Temperature (Soldering 10s) | 300°C |
| (SOIC - Lead Tips Only) | |

Operating Conditions

| | |
|--|----------------|
| Temperature Range, T_A | -55°C to 125°C |
| Supply Voltage Range, V_{CC} | |
| HC Types | .2V to 6V |
| HCT Types | .4.5V to 5.5V |
| DC Input or Output Voltage, V_I, V_O | 0V to V_{CC} |
| Input Rise and Fall Time | |
| 2V | 1000ns (Max) |
| 4.5V | 500ns (Max) |
| 6V | 400ns (Max) |

CAUTION: Stresses above those listed in "Absolute Maximum Ratings" may cause permanent damage to the device. This is a stress only rating and operation of the device at these or any other conditions above those indicated in the operational sections of this specification is not implied.

NOTE:

- The package thermal impedance is calculated in accordance with JESD 51-7.

DC Electrical Specifications

| PARAMETER | SYMBOL | TEST CONDITIONS | | V_{CC} (V) | 25°C | | | -40°C TO 85°C | | -55°C TO 125°C | | UNITS | |
|---|----------|----------------------|------------|--------------|------|------|-----------|---------------|---------|----------------|---------|------------|---|
| | | V_I (V) | I_O (mA) | | MIN | TYP | MAX | MIN | MAX | MIN | MAX | | |
| HC TYPES | | | | | | | | | | | | | |
| High Level Input Voltage | V_{IH} | - | - | 2 | 1.5 | - | - | 1.5 | - | 1.5 | - | V | |
| | | | | 4.5 | 3.15 | - | - | 3.15 | - | 3.15 | - | V | |
| | | | | 6 | 4.2 | - | - | 4.2 | - | 4.2 | - | V | |
| Low Level Input Voltage | V_{IL} | - | - | 2 | - | - | 0.5 | - | 0.5 | - | 0.5 | V | |
| | | | | 4.5 | - | - | 1.35 | - | 1.35 | - | 1.35 | V | |
| | | | | 6 | - | - | 1.8 | - | 1.8 | - | 1.8 | V | |
| High Level Output Voltage CMOS Loads | V_{OH} | V_{IH} or V_{IL} | -0.02 | -0.02 | 2 | 1.9 | - | - | 1.9 | - | 1.9 | - | V |
| | | | -0.02 | -0.02 | 4.5 | 4.4 | - | - | 4.4 | - | 4.4 | - | V |
| | | | -0.02 | -0.02 | 6 | 5.9 | - | - | 5.9 | - | 5.9 | - | V |
| High Level Output Voltage TTL Loads | V_{OH} | V_{IH} or V_{IL} | - | - | - | - | - | - | - | - | - | V | |
| | | | -6 | -6 | 4.5 | 3.98 | - | - | 3.84 | - | 3.7 | - | V |
| | | | -7.8 | -7.8 | 6 | 5.48 | - | - | 5.34 | - | 5.2 | - | V |
| Low Level Output Voltage CMOS Loads | V_{OL} | V_{IH} or V_{IL} | 0.02 | 0.02 | 2 | - | - | 0.1 | - | 0.1 | - | 0.1 | V |
| | | | 0.02 | 0.02 | 4.5 | - | - | 0.1 | - | 0.1 | - | 0.1 | V |
| | | | 0.02 | 0.02 | 6 | - | - | 0.1 | - | 0.1 | - | 0.1 | V |
| Low Level Output Voltage TTL Loads | V_{OL} | V_{IH} or V_{IL} | - | - | - | - | - | - | - | - | - | V | |
| | | | 6 | 6 | 4.5 | - | - | 0.26 | - | 0.33 | - | 0.4 | V |
| | | | 7.8 | 7.8 | 6 | - | - | 0.26 | - | 0.33 | - | 0.4 | V |
| Input Leakage Current | I_I | V_{CC} or GND | - | 6 | - | - | ± 0.1 | - | ± 1 | - | ± 1 | ∞A | |

CD54HC670, CD74HC670, CD74HCT670

DC Electrical Specifications (Continued)

| PARAMETER | SYMBOL | TEST CONDITIONS | | V _{CC} (V) | 25°C | | | -40°C TO 85°C | | -55°C TO 125°C | | UNITS |
|--|---------------------------|------------------------------------|---|---------------------|------|-----|------|---------------|------|----------------|-----|-------|
| | | V _I (V) | I _O (mA) | | MIN | TYP | MAX | MIN | MAX | MIN | MAX | |
| Quiescent Device Current | I _{CC} | V _{CC} or GND | 0 | 6 | - | - | 8 | - | 80 | - | 160 | ∞A |
| Three- State Leakage Current | | V _{IL} or V _{IH} | V _O = V _{CC} or GND | 6 | - | - | ±0.5 | - | ±5.0 | - | ±10 | ∞A |
| HCT TYPES | | | | | | | | | | | | |
| High Level Input Voltage | V _{IH} | - | - | 4.5 to 5.5 | 2 | - | - | 2 | - | 2 | - | V |
| Low Level Input Voltage | V _{IL} | - | - | 4.5 to 5.5 | - | - | 0.8 | - | 0.8 | - | 0.8 | V |
| High Level Output Voltage CMOS Loads | V _{OH} | V _{IH} or V _{IL} | -0.02 | 4.5 | 4.4 | - | - | 4.4 | - | 4.4 | - | V |
| High Level Output Voltage TTL Loads | | | -6 | 4.5 | 3.98 | - | - | 3.84 | - | 3.7 | - | V |
| Low Level Output Voltage CMOS Loads | V _{OL} | V _{IH} or V _{IL} | 0.02 | 4.5 | - | - | 0.1 | - | 0.1 | - | 0.1 | V |
| Low Level Output Voltage TTL Loads | | | 6 | 4.5 | - | - | 0.26 | - | 0.33 | - | 0.4 | V |
| Input Leakage Current | I _I | V _{CC} and GND | 0 | 5.5 | - | - | ±0.1 | - | ±1 | - | ±1 | ∞A |
| Quiescent Device Current | I _{CC} | V _{CC} or GND | 0 | 5.5 | - | - | 8 | - | 80 | - | 160 | ∞A |
| Three- State Leakage Current | | V _{IL} or V _{IH} | V _O = V _{CC} or GND | 5.5 | - | - | ±0.5 | - | ±5.0 | - | ±10 | ∞A |
| Additional Quiescent Device Current Per Input Pin: 1 Unit Load | ΔI _{CC} (Note 4) | V _{CC} -2.1 | - | 4.5 to 5.5 | - | 100 | 360 | - | 450 | - | 490 | ∞A |

NOTE:

4. For dual-supply systems theoretical worst case (V_I = 2.4V, V_{CC} = 5.5V) specification is 1.8mA.

HCT Input Loading Table

| INPUT | UNIT LOADS |
|-----------------|------------|
| \overline{WE} | 0.3 |
| WA0 | 0.2 |
| WA1 | 0.4 |
| \overline{RE} | 1.5 |
| DATA | 0.15 |
| RA0 | 0.4 |
| RA1 | 0.7 |

NOTE: Unit Load is ΔI_{CC} limit specific in DC Electrical Specifications Table, e.g., 360∞A max. at 25°C.

CD54HC670, CD74HC670, CD74HCT670

Prerequisite for Switching Specifications

| PARAMETER | SYMBOL | V _{CC} (V) | 25°C | | | -40°C TO 85°C | | | -55°C TO 125°C | | | UNITS |
|---|---------------|---------------------|------|-----|-----|---------------|-----|-----|----------------|-----|-----|-------|
| | | | MIN | TYP | MAX | MIN | TYP | MAX | MIN | TYP | MAX | |
| HC TYPES | | | | | | | | | | | | |
| Setup Time Data to \overline{WE} Write to \overline{WE} | t_{SU}, t_H | 2 | 60 | - | - | 75 | - | - | 90 | - | - | ns |
| | | 4.5 | 12 | - | - | 15 | - | - | 18 | - | - | ns |
| | | 6 | 10 | - | - | 13 | - | - | 15 | - | - | ns |
| Hold Time Data to \overline{WE} Write to \overline{WE} | t_H, t_W | 2 | 5 | - | - | 5 | - | - | 5 | - | - | ns |
| | | 4.5 | 5 | - | - | 5 | - | - | 5 | - | - | ns |
| | | 6 | 5 | - | - | 5 | - | - | 5 | - | - | ns |
| Pulse Width \overline{WE} | t_W | 2 | 80 | - | - | 100 | - | - | 120 | - | - | ns |
| | | 4.5 | 16 | - | - | 20 | - | - | 24 | - | - | ns |
| | | 6 | 14 | - | - | 17 | - | - | 20 | - | - | ns |
| Latch Time \overline{WE} to RA0, RA1 | t_{LATCH} | 2 | 100 | - | - | 125 | - | - | 150 | - | - | ns |
| | | 4.5 | 20 | - | - | 25 | - | - | 30 | - | - | ns |
| | | 6 | 17 | - | - | 21 | - | - | 26 | - | - | ns |
| HCT TYPES | | | | | | | | | | | | |
| Setup Time Data to \overline{WE} | t_{SU}, t_H | 4.5 | 12 | - | - | 15 | - | - | 18 | - | - | ns |
| Hold Time Data to \overline{WE} Write to \overline{WE} | t_H, t_W | 4.5 | 5 | - | - | 5 | - | - | 5 | - | - | ns |
| Setup Time Write to \overline{WE} | t_{SU} | 4.5 | 18 | - | - | 23 | - | - | 27 | - | - | ns |
| Pulse Width \overline{WE} | t_W | 4.5 | 20 | - | - | 25 | - | - | 30 | - | - | ns |
| Latch Time \overline{WE} to RA0, RA1 | t_{LATCH} | 4.5 | 25 | - | - | 31 | - | - | 38 | - | - | ns |

Switching Specifications C_L = 50pF, Input t_r, t_f = 6ns

| PARAMETER | SYMBOL | TEST CONDITIONS | V _{CC} (V) | 25°C | | | -40°C TO 85°C | | -55°C TO 125°C | | UNITS |
|---------------------------------------|--------------------|-----------------------|---------------------|------|-----|-----|------------------|-----|-------------------|-----|-------|
| | | | | MIN | TYP | MAX | MIN | MAX | MIN | MAX | |
| HC TYPES | | | | | | | | | | | |
| Propagation Delay Reading Any Word | t_{PLH}, t_{PHL} | C _L = 50pF | 2 | - | - | 195 | - | 245 | - | 295 | ns |
| | | | 4.5 | - | - | 39 | - | 49 | - | 59 | ns |
| | | C _L = 15pF | 5 | - | 16 | - | - | - | - | - | ns |
| | | C _L = 50pF | 6 | - | - | 33 | - | 42 | - | 50 | ns |
| Write Enable to Output | t_{PLH}, t_{PHL} | C _L = 50pF | 2 | - | - | 250 | - | 315 | - | 375 | ns |
| | | | 4.5 | - | - | 50 | - | 63 | - | 75 | ns |
| | | C _L = 15pF | 5 | - | 21 | - | - | - | - | - | ns |
| | | C _L = 50pF | 6 | - | - | 43 | - | 54 | - | 64 | ns |

CD54HC670, CD74HC670, CD74HCT670

Switching Specifications $C_L = 50\text{pF}$, Input $t_r, t_f = 6\text{ns}$ (Continued)

| PARAMETER | SYMBOL | TEST CONDITIONS | V_{CC} (V) | 25°C | | | -40°C TO 85°C | | -55°C TO 125°C | | UNITS |
|--|--------------------|---------------------|--------------|------|-----|-----|---------------|-----|----------------|-----|-------|
| | | | | MIN | TYP | MAX | MIN | MAX | MIN | MAX | |
| Data to Output | t_{PLH}, t_{PHL} | $C_L = 50\text{pF}$ | 2 | - | - | 256 | - | 315 | - | 375 | ns |
| | | | 4.5 | - | - | 50 | - | 63 | - | 75 | ns |
| | | $C_L = 15\text{pF}$ | 5 | - | 21 | - | - | - | - | - | ns |
| | | $C_L = 50\text{pF}$ | 6 | - | - | 43 | - | 54 | - | 64 | ns |
| Output Disable Time | t_{PLZ}, t_{PHZ} | $C_L = 50\text{pF}$ | 2 | - | - | 150 | - | 190 | - | 225 | ns |
| | | | 4.5 | - | - | 30 | - | 38 | - | 45 | ns |
| | | $C_L = 15\text{pF}$ | 5 | - | 12 | - | - | - | - | - | ns |
| | | $C_L = 50\text{pF}$ | 6 | - | - | 26 | - | 33 | - | 38 | ns |
| Output Enable Time | t_{PZL}, t_{PZH} | $C_L = 50\text{pF}$ | 2 | - | - | 150 | - | 190 | - | 225 | ns |
| | | | 4.5 | - | - | 30 | - | 38 | - | 45 | ns |
| | | $C_L = 15\text{pF}$ | 5 | - | 12 | - | - | - | - | - | ns |
| | | $C_L = 50\text{pF}$ | 6 | - | - | 26 | - | 33 | - | 38 | ns |
| Output Transition Time | t_{THL}, t_{TLH} | $C_L = 50\text{pF}$ | 2 | - | - | 75 | - | 95 | - | 110 | ns |
| | | | 4.5 | - | - | 15 | - | 19 | - | 22 | ns |
| | | | 6 | - | - | 13 | - | 10 | - | 19 | ns |
| Input Capacitance | C_I | $C_L = 50\text{pF}$ | - | 10 | - | 10 | - | 10 | - | 10 | pF |
| Three-State Output Capacitance | C_O | - | - | 20 | - | 20 | - | 20 | - | 20 | pF |
| Power Dissipation Capacitance (Notes 5, 6) | C_{PD} | $C_L = 15\text{pF}$ | 5 | - | 59 | - | - | - | - | - | pF |
| HCT TYPES | | | | | | | | | | | |
| Propagation Delay Reading Any Word | t_{PHL}, t_{PLH} | $C_L = 50\text{pF}$ | 4.5 | - | - | 40 | - | 50 | - | 53 | ns |
| | | $C_L = 15\text{pF}$ | 5 | - | 17 | - | - | - | - | - | ns |
| Write Enable to Output | t_{PHL}, t_{PLH} | $C_L = 50\text{pF}$ | 4.5 | - | - | 50 | - | 63 | - | 75 | ns |
| | | $C_L = 15\text{pF}$ | 5 | - | 21 | - | - | - | - | - | ns |
| Data to Output | t_{PHL}, t_{PLH} | $C_L = 50\text{pF}$ | 4.5 | - | - | 50 | - | 63 | - | 75 | ns |
| | | $C_L = 15\text{pF}$ | 5 | - | 21 | - | - | - | - | - | ns |
| Output Disable Time | t_{PLZ}, t_{PHZ} | $C_L = 50\text{pF}$ | 4.5 | - | - | 35 | - | 44 | - | 53 | ns |
| | | $C_L = 15\text{pF}$ | 5 | - | 14 | - | - | - | - | - | ns |
| Output Enable Time | t_{PZL}, t_{PZH} | $C_L = 50\text{pF}$ | 4.5 | - | - | 38 | - | 48 | - | 57 | ns |
| | | $C_L = 15\text{pF}$ | 5 | - | 16 | - | - | - | - | - | ns |
| Output Transition Time | t_{TLH}, t_{THL} | $C_L = 50\text{pF}$ | 4.5 | - | - | 15 | - | 19 | - | 22 | ns |
| Input Capacitance | C_I | $C_L = 50\text{pF}$ | - | 10 | - | 10 | - | 10 | - | 10 | pF |
| Three-State Output Capacitance | C_O | - | - | 20 | - | 20 | - | 20 | - | 20 | pF |
| Power Dissipation Capacitance (Notes 5, 6) | C_{PD} | $C_L = 15\text{pF}$ | 5 | - | 66 | - | - | - | - | - | pF |

NOTES:

- C_{PD} is used to determine the dynamic power consumption, per output.
- $P_D = C_{PD} V_{CC}^2 f_i + \sum C_L V_{CC}^2 f_O$ where f_i = Input Frequency, f_O = Output Frequency, C_L = Output Load Capacitance, V_{CC} = Supply Voltage.

Test Circuits and Waveforms

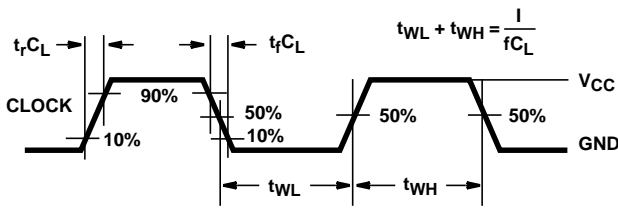

NOTE: Outputs should be switching from 10% V_{CC} to 90% V_{CC} in accordance with device truth table. For f_{MAX}, input duty cycle = 50%.

FIGURE 1. HC CLOCK PULSE RISE AND FALL TIMES AND PULSE WIDTH

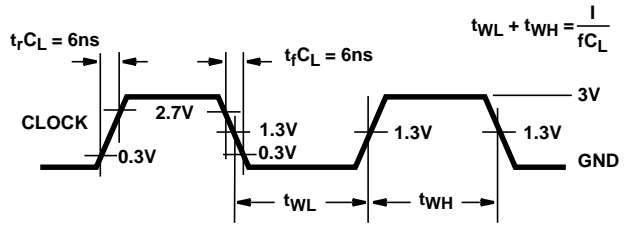

NOTE: Outputs should be switching from 10% V_{CC} to 90% V_{CC} in accordance with device truth table. For f_{MAX}, input duty cycle = 50%.

FIGURE 2. HCT CLOCK PULSE RISE AND FALL TIMES AND PULSE WIDTH

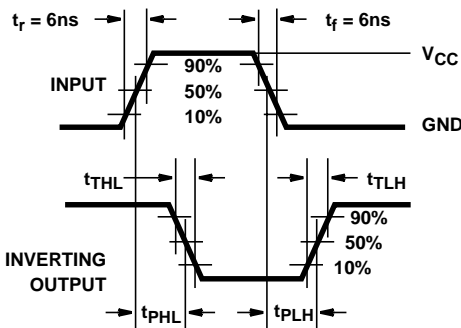

FIGURE 3. HC TRANSITION TIMES AND PROPAGATION DELAY TIMES, COMBINATION LOGIC

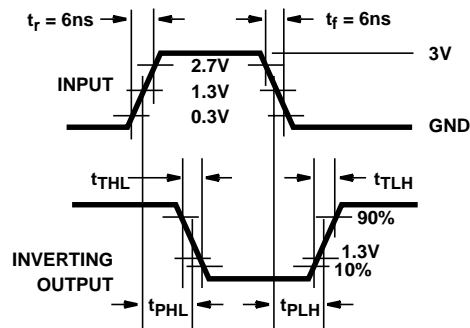

FIGURE 4. HCT TRANSITION TIMES AND PROPAGATION DELAY TIMES, COMBINATION LOGIC

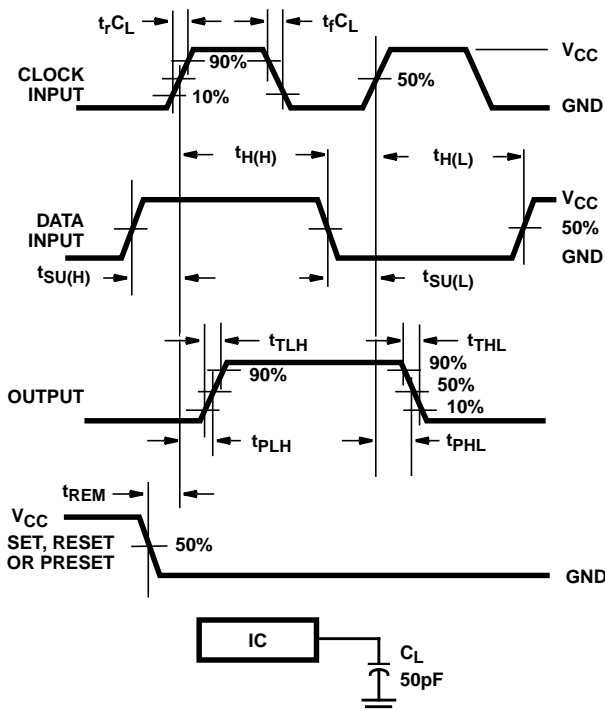

FIGURE 5. HC SETUP TIMES, HOLD TIMES, REMOVAL TIME, AND PROPAGATION DELAY TIMES FOR EDGE TRIGGERED SEQUENTIAL LOGIC CIRCUITS

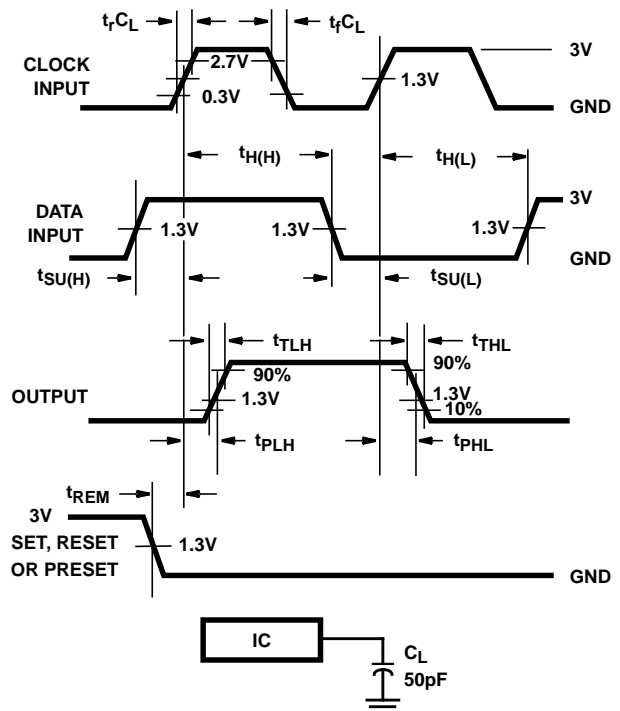

FIGURE 6. HCT SETUP TIMES, HOLD TIMES, REMOVAL TIME, AND PROPAGATION DELAY TIMES FOR EDGE TRIGGERED SEQUENTIAL LOGIC CIRCUITS

Test Circuits and Waveforms (Continued)

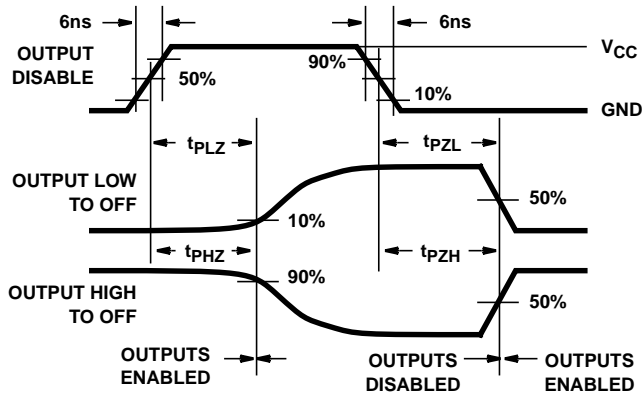

FIGURE 7. HC THREE-STATE PROPAGATION DELAY WAVEFORM

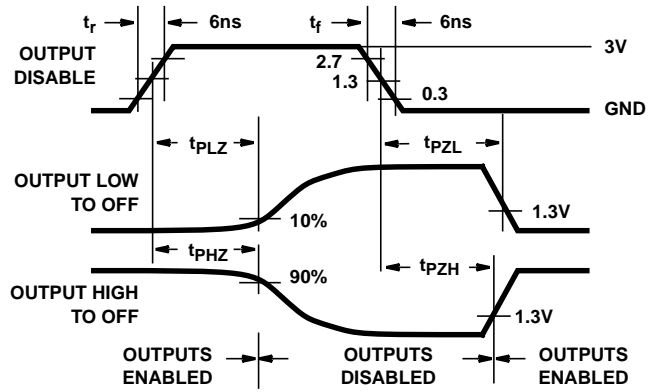
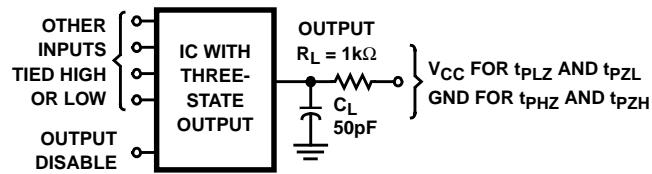

FIGURE 8. HCT THREE-STATE PROPAGATION DELAY WAVEFORM



NOTE: Open drain waveforms t_{PLZ} and t_{PZL} are the same as those for three-state shown on the left. The test circuit is Output $R_L = 1k\Omega$ to V_{CC} , $C_L = 50pF$.

FIGURE 9. HC AND HCT THREE-STATE PROPAGATION DELAY TEST CIRCUIT

PACKAGING INFORMATION

| Orderable Device | Status (1) | Package Type | Package Drawing | Pins | Package Qty | Eco Plan (2) | Lead finish/ Ball material (6) | MSL Peak Temp (3) | Op Temp (°C) | Device Marking (4/5) | Samples |
|------------------|---------------|--------------|-----------------|------|-------------|-----------------|--------------------------------------|----------------------|--------------|-------------------------|-------------------------|
| CD74HC670E | ACTIVE | PDIP | N | 16 | 25 | RoHS & Green | NIPDAU | N / A for Pkg Type | -55 to 125 | CD74HC670E | Samples |
| CD74HC670M | LIFEBUY | SOIC | D | 16 | 40 | RoHS & Green | NIPDAU | Level-1-260C-UNLIM | -55 to 125 | HC670M | |
| CD74HC670M96 | ACTIVE | SOIC | D | 16 | 2500 | RoHS & Green | NIPDAU | Level-1-260C-UNLIM | -55 to 125 | HC670M | Samples |
| CD74HCT670E | ACTIVE | PDIP | N | 16 | 25 | RoHS & Green | NIPDAU | N / A for Pkg Type | -55 to 125 | CD74HCT670E | Samples |
| CD74HCT670M | ACTIVE | SOIC | D | 16 | 40 | RoHS & Green | NIPDAU | Level-1-260C-UNLIM | -55 to 125 | HCT670M | Samples |

(1) The marketing status values are defined as follows:

ACTIVE: Product device recommended for new designs.

LIFEBUY: TI has announced that the device will be discontinued, and a lifetime-buy period is in effect.

NRND: Not recommended for new designs. Device is in production to support existing customers, but TI does not recommend using this part in a new design.

PREVIEW: Device has been announced but is not in production. Samples may or may not be available.

OBSOLETE: TI has discontinued the production of the device.

(2) **RoHS:** TI defines "RoHS" to mean semiconductor products that are compliant with the current EU RoHS requirements for all 10 RoHS substances, including the requirement that RoHS substance do not exceed 0.1% by weight in homogeneous materials. Where designed to be soldered at high temperatures, "RoHS" products are suitable for use in specified lead-free processes. TI may reference these types of products as "Pb-Free".

RoHS Exempt: TI defines "RoHS Exempt" to mean products that contain lead but are compliant with EU RoHS pursuant to a specific EU RoHS exemption.

Green: TI defines "Green" to mean the content of Chlorine (Cl) and Bromine (Br) based flame retardants meet JS709B low halogen requirements of <=1000ppm threshold. Antimony trioxide based flame retardants must also meet the <=1000ppm threshold requirement.

(3) MSL, Peak Temp. - The Moisture Sensitivity Level rating according to the JEDEC industry standard classifications, and peak solder temperature.

(4) There may be additional marking, which relates to the logo, the lot trace code information, or the environmental category on the device.

(5) Multiple Device Markings will be inside parentheses. Only one Device Marking contained in parentheses and separated by a "~" will appear on a device. If a line is indented then it is a continuation of the previous line and the two combined represent the entire Device Marking for that device.

(6) Lead finish/Ball material - Orderable Devices may have multiple material finish options. Finish options are separated by a vertical ruled line. Lead finish/Ball material values may wrap to two lines if the finish value exceeds the maximum column width.

Important Information and Disclaimer: The information provided on this page represents TI's knowledge and belief as of the date that it is provided. TI bases its knowledge and belief on information provided by third parties, and makes no representation or warranty as to the accuracy of such information. Efforts are underway to better integrate information from third parties. TI has taken and

continues to take reasonable steps to provide representative and accurate information but may not have conducted destructive testing or chemical analysis on incoming materials and chemicals. TI and TI suppliers consider certain information to be proprietary, and thus CAS numbers and other limited information may not be available for release.

In no event shall TI's liability arising out of such information exceed the total purchase price of the TI part(s) at issue in this document sold by TI to Customer on an annual basis.

TAPE AND REEL INFORMATION

QUADRANT ASSIGNMENTS FOR PIN 1 ORIENTATION IN TAPE

*All dimensions are nominal

| Device | Package Type | Package Drawing | Pins | SPQ | Reel Diameter (mm) | Reel Width W1 (mm) | A0 (mm) | B0 (mm) | K0 (mm) | P1 (mm) | W (mm) | Pin1 Quadrant |
|--------------|--------------|-----------------|------|------|--------------------|--------------------|---------|---------|---------|---------|--------|---------------|
| CD74HC670M96 | SOIC | D | 16 | 2500 | 330.0 | 16.4 | 6.5 | 10.3 | 2.1 | 8.0 | 16.0 | Q1 |

TAPE AND REEL BOX DIMENSIONS

*All dimensions are nominal

| Device | Package Type | Package Drawing | Pins | SPQ | Length (mm) | Width (mm) | Height (mm) |
|--------------|--------------|-----------------|------|------|-------------|------------|-------------|
| CD74HC670M96 | SOIC | D | 16 | 2500 | 340.5 | 336.1 | 32.0 |

TUBE

*All dimensions are nominal



| Device | Package Name | Package Type | Pins | SPQ | L (mm) | W (mm) | T (μm) | B (mm) |
|-------------|--------------|--------------|------|-----|--------|--------|--------|--------|
| CD74HC670E | N | PDIP | 16 | 25 | 506 | 13.97 | 11230 | 4.32 |
| CD74HC670E | N | PDIP | 16 | 25 | 506 | 13.97 | 11230 | 4.32 |
| CD74HC670M | D | SOIC | 16 | 40 | 507 | 8 | 3940 | 4.32 |
| CD74HCT670E | N | PDIP | 16 | 25 | 506 | 13.97 | 11230 | 4.32 |
| CD74HCT670E | N | PDIP | 16 | 25 | 506 | 13.97 | 11230 | 4.32 |
| CD74HCT670M | D | SOIC | 16 | 40 | 507 | 8 | 3940 | 4.32 |

D (R-PDSO-G16)

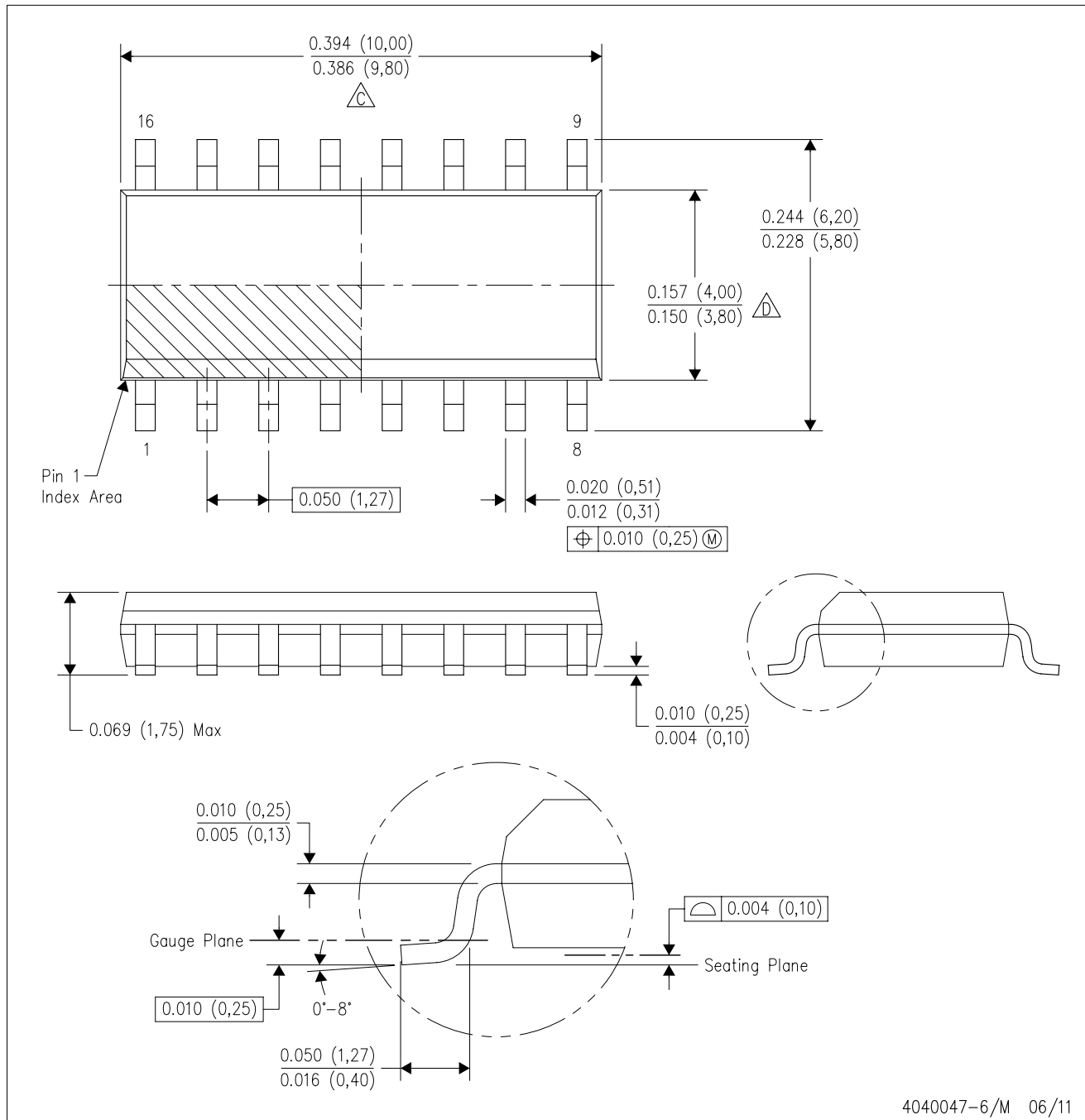
PLASTIC SMALL OUTLINE



4040047-6/M 06/11

- NOTES:
- A. All linear dimensions are in inches (millimeters).
 - B. This drawing is subject to change without notice.
 -  C. Body length does not include mold flash, protrusions, or gate burrs. Mold flash, protrusions, or gate burrs shall not exceed 0.006 (0,15) each side.
 -  D. Body width does not include interlead flash. Interlead flash shall not exceed 0.017 (0,43) each side.
 - E. Reference JEDEC MS-012 variation AC.

N (R-PDIP-T**)

PLASTIC DUAL-IN-LINE PACKAGE

16 PINS SHOWN



- NOTES:
- A. All linear dimensions are in inches (millimeters).
 - B. This drawing is subject to change without notice.
 - $\triangle C$ Falls within JEDEC MS-001, except 18 and 20 pin minimum body length (Dim A).
 - $\triangle D$ The 20 pin end lead shoulder width is a vendor option, either half or full width.

4040049/E 12/2002

IMPORTANT NOTICE AND DISCLAIMER

TI PROVIDES TECHNICAL AND RELIABILITY DATA (INCLUDING DATA SHEETS), DESIGN RESOURCES (INCLUDING REFERENCE DESIGNS), APPLICATION OR OTHER DESIGN ADVICE, WEB TOOLS, SAFETY INFORMATION, AND OTHER RESOURCES "AS IS" AND WITH ALL FAULTS, AND DISCLAIMS ALL WARRANTIES, EXPRESS AND IMPLIED, INCLUDING WITHOUT LIMITATION ANY IMPLIED WARRANTIES OF MERCHANTABILITY, FITNESS FOR A PARTICULAR PURPOSE OR NON-INFRINGEMENT OF THIRD PARTY INTELLECTUAL PROPERTY RIGHTS.

These resources are intended for skilled developers designing with TI products. You are solely responsible for (1) selecting the appropriate TI products for your application, (2) designing, validating and testing your application, and (3) ensuring your application meets applicable standards, and any other safety, security, regulatory or other requirements.

These resources are subject to change without notice. TI grants you permission to use these resources only for development of an application that uses the TI products described in the resource. Other reproduction and display of these resources is prohibited. No license is granted to any other TI intellectual property right or to any third party intellectual property right. TI disclaims responsibility for, and you will fully indemnify TI and its representatives against, any claims, damages, costs, losses, and liabilities arising out of your use of these resources.

TI's products are provided subject to [TI's Terms of Sale](#) or other applicable terms available either on [ti.com](https://www.ti.com) or provided in conjunction with such TI products. TI's provision of these resources does not expand or otherwise alter TI's applicable warranties or warranty disclaimers for TI products.

TI objects to and rejects any additional or different terms you may have proposed.

Mailing Address: Texas Instruments, Post Office Box 655303, Dallas, Texas 75265
Copyright © 2023, Texas Instruments Incorporated