

ISO1500 3-kV_{RMS} Basic Isolated RS-485/RS-422 Transceiver in Ultra-Small Package

1 Features

- Meets or exceeds requirements of TIA/EIA-485-A
- Half-duplex transceiver
- Low-EMI 1-Mbps data rate
- Bus I/O protection
 - ± 16 kV HBM ESD
- 1.71-V to 5.5-V Logic-side supply (V_{CC1}), 4.5-V to 5.5-V Bus-side supply (V_{CC2})
- 1/8 Unit load: up to 256 nodes on bus
- Failsafe receiver for bus open, short, and idle
- 100-kV/ μ s (typical) High common-mode transient immunity
- Extended temperature range from -40°C to $+125^{\circ}\text{C}$
- Glitch-free power-up and power-down for hot plug-in
- Ultra-small SSOP (DBQ-16) package
- Safety-related certifications:
 - 4242- V_{PK} V_{IOTM} and 566- V_{PK} V_{IORM} per DIN VDE V 0884-11:2017-01
 - 3000- V_{RMS} Isolation for 1 minute per UL 1577
 - IEC 60950-1, IEC 62368-1 and IEC 61010-1 certifications
 - CQC, TUV, and CSA certifications

2 Applications

- [Electricity meters](#)
- [Protection relay](#)
- [Factory automation & control](#)
- [HVAC systems and building automation](#)
- [Motor drives](#)

3 Description

The ISO1500 device is a galvanically-isolated differential line transceiver for TIA/EIA RS-485 and RS-422 applications. This device has a 3-channel digital isolator and an RS-485 transceiver in an ultra-small 16-pin SSOP package. The bus pins of this transceiver are protected against IEC ESD contact discharge and IEC EFT events. The receiver output has a failsafe for bus open, short, and idle conditions. The small solution size of ISO1500 greatly reduces the board space required compared to other integrated isolated RS-485 solutions or discrete implementation with optocouplers and non-isolated RS-485 transceiver.

The device is used for long distance communications. Isolation breaks the ground loop between the communicating nodes, allowing for a much larger common mode voltage range. The symmetrical isolation barrier of each device is tested to provide 3000 V_{RMS} of isolation for 1 minute per UL 1577 between the bus-line transceiver and the logic-level interface.

The ISO1500 device can operate from 1.71 V to 5.5 V on side 1 which lets the devices interface with low-voltage FPGAs and ASICs. The supply voltage on side 2 is from 4.5 V to 5.5 V. This device supports a wide operating ambient temperature range from -40°C to $+125^{\circ}\text{C}$.

Device Information⁽¹⁾

PART NUMBER	PACKAGE	BODY SIZE (NOM)
ISO1500	SSOP (16)	4.90 mm × 3.90 mm

(1) For all available packages, see the orderable addendum at the end of the data sheet.

Simplified Schematic

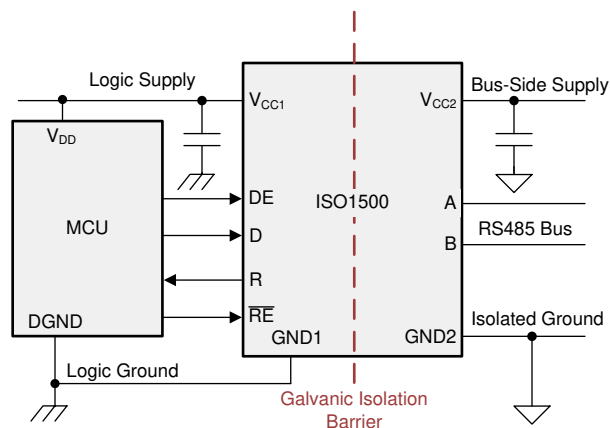

Table of Contents

1 Features	1	7 Parameter Measurement Information	15
2 Applications	1	8 Detailed Description	18
3 Description	1	8.1 Overview	18
4 Revision History	2	8.2 Functional Block Diagram	18
5 Pin Configuration and Functions	3	8.3 Feature Description	18
6 Specifications	4	8.4 Device Functional Modes	20
6.1 Absolute Maximum Ratings	4	9 Application and Implementation	22
6.2 ESD Ratings	4	9.1 Application Information	22
6.3 Recommended Operating Conditions	4	9.2 Typical Application	23
6.4 Thermal Information	4	10 Power Supply Recommendations	24
6.5 Power Ratings	5	11 Layout	25
6.6 Insulation Specifications	6	11.1 Layout Guidelines	25
6.7 Safety-Related Certifications	7	11.2 Layout Example	25
6.8 Safety Limiting Values	7	12 Device and Documentation Support	27
6.9 Electrical Characteristics: Driver	8	12.1 Documentation Support	27
6.10 Electrical Characteristics: Receiver	8	12.2 Receiving Notification of Documentation Updates	27
6.11 Supply Current Characteristics: Side 1(I _{CC1})	9	12.3 Community Resource	27
6.12 Supply Current Characteristics: Side 2(I _{CC2})	9	12.4 Trademarks	27
6.13 Switching Characteristics: Driver	10	12.5 Electrostatic Discharge Caution	27
6.14 Switching Characteristics: Receiver	10	12.6 Glossary	27
6.15 Insulation Characteristics Curves	10	13 Mechanical, Packaging, and Orderable Information	27
6.16 Typical Characteristics	11		

4 Revision History

NOTE: Page numbers for previous revisions may differ from page numbers in the current version.

Changes from Revision C (September 2019) to Revision D	Page
• Added updated certification information in Safety-Related Certifications	7

Changes from Revision B (May 2019) to Revision C	Page
• Changed certificate related info in Features section	1
• Added footnote to Pin function table for NC pin	3

Changes from Revision A (December 2018) to Revision B	Page
• Added HBM ESD to feature list	1

Changes from Original (September 2018) to Revision A	Page
• Changed device status from Advanced Information to Production Data	1

5 Pin Configuration and Functions

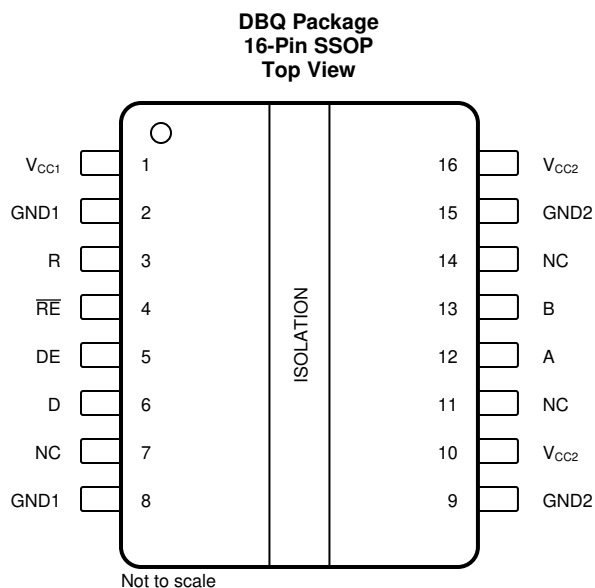

Pin Functions

PIN		I/O	DESCRIPTION
NAME	NO.		
A	12	I/O	Transceiver noninverting input or output (I/O) on the bus side
B	13	I/O	Transceiver inverting input or output (I/O) on the bus side
D	6	I	Driver input
DE	5	I	Driver enable. This pin enables the driver output when high and disables the driver output when low or open.
GND1	2	—	Ground connection for V_{CC1}
	8		
GND2	9	—	Ground connection for V_{CC2}
	15		
NC ⁽¹⁾	7	—	No internal connection
	11		
	14		
R	3	O	Receiver output
\overline{RE}	4	I	Receiver enable. This pin disables the receiver output when high or open and enables the receiver output when low.
V_{CC1}	1	—	Logic-side power supply
V_{CC2}	10	—	Transceiver-side power supply. These pins are not connected internally and must be shorted externally on PCB.
	16		

(1) Device functionality is not affected if NC pins are connected to supply or ground on PCB

6 Specifications

6.1 Absolute Maximum Ratings

Over operating free-air temperature range (unless otherwise noted)⁽¹⁾⁽²⁾

		MIN	MAX	UNIT
V _{CC1}	Supply voltage, side 1	-0.5	6	V
V _{CC2}	Supply voltage, side 2	-0.5	6	V
V _{IO}	Logic voltage level (D, DE, \overline{RE} , R)	-0.5	V _{CC1} +0.5 ⁽³⁾	V
I _O	Output current on R pin	-15	15	mA
V _{BUS}	Voltage on bus pins (A, B, Y, Z w.r.t GND2)	-18	18	V
T _J	Junction temperature	-40	150	°C
T _{STG}	Storage temperature	-65	150	°C

- Stresses beyond those listed under *Absolute Maximum Ratings* may cause permanent damage to the device. These are stress ratings only, which do not imply functional operation of the device at these or any other conditions beyond those indicated under *Recommended Operating Conditions*. Exposure to absolute-maximum-rated conditions for extended periods may affect device reliability.
- All voltage values except differential I/O bus voltages are with respect to the local ground terminal (GND1 or GND2) and are peak voltage values.
- Maximum voltage must not exceed 6 V

6.2 ESD Ratings

			VALUE	UNIT
V _(ESD)	Electrostatic discharge Human body model (HBM), per ANSI/ESDA/JEDEC JS-001	All pins except bus pins ⁽¹⁾	±4000	V
		Bus terminals to GND2 ⁽¹⁾	±16000	V
	Electrostatic discharge Charged device model (CDM), per JEDEC specification JESD22-C101	All pins ⁽²⁾	±1500	

- JEDEC document JEP155 states that 500-V HBM allows safe manufacturing with a standard ESD control process.
- JEDEC document JEP157 states that 250-V CDM allows safe manufacturing with a standard ESD control process.

6.3 Recommended Operating Conditions

		MIN	MAX	UNIT
V _{CC1}	Supply Voltage, Side 1, 1.8-V operation	1.71	1.89	V
	Supply Voltage, Side 1, 2.5-V, 3.3-V and 5.5-V operation	2.25	5.5	V
V _{CC2}	Supply Voltage, Side 2	4.5	5.5	V
V _I	Common mode voltage at any bus terminal: A or B	-7	12	V
V _{IH}	High-level input voltage (D, DE, \overline{RE} inputs)	0.7*V _{CC1}	V _{CC1}	V
V _{IL}	Low-level input voltage (D, DE, \overline{RE} inputs)	0	0.3*V _{CC1}	V
V _{ID}	Differential input voltage	-12	12	V
I _O	Output current, Driver	-60	60	mA
I _{OR}	Output current, Receiver	-4	4	mA
R _L	Differential load resistance	54		Ω
1/t _{UI}	Signaling rate		1	Mbps
T _A	Operating ambient temperature	-40	125	°C

6.4 Thermal Information

THERMAL METRIC ⁽¹⁾		ISO1500	UNIT
		DBQ (SSOP)	
		16 PINS	
R _{θJA}	Junction-to-ambient thermal resistance	112.7	°C/W
R _{θJC(top)}	Junction-to-case (top) thermal resistance	57.2	°C/W

- For more information about traditional and new thermal metrics, see the [Semiconductor and IC Package Thermal Metrics](#) application report.

Thermal Information (continued)

THERMAL METRIC ⁽¹⁾		ISO1500	UNIT
		DBQ (SSOP)	
		16 PINS	
$R_{\theta JB}$	Junction-to-board thermal resistance	64.0	°C/W
Ψ_{JT}	Junction-to-top characterization parameter	32.1	°C/W
Ψ_{JB}	Junction-to-board characterization parameter	63.7	°C/W
$R_{\theta JC(bot)}$	Junction-to-case (bottom) thermal resistance	--	°C/W

6.5 Power Ratings

PARAMETER		TEST CONDITIONS	MIN	TYP	MAX	UNIT
P_D	Maximum power dissipation (both sides)	$V_{CC1} = V_{CC2} = 5.5\text{ V}$, $T_A = 125^\circ\text{C}$, $T_J = 150^\circ\text{C}$, A-B load = $54\ \Omega \parallel 50\text{pF}$, Load on $R = 15\text{pF}$ Input a 500kHz 50% duty cycle square wave to D pin with $V_{DE} = V_{CC1}$, $\overline{V_{RE}} = \text{GND1}$			278	mW
P_{D1}	Maximum power dissipation (side-1)				28	mW
P_{D2}	Maximum power dissipation (side-2)				250	mW

6.6 Insulation Specifications

PARAMETER		TEST CONDITIONS	SPECIFICATIONS	UNIT
			DBQ-16	
IEC 60664-1				
CLR	External clearance ⁽¹⁾	Side 1 to side 2 distance through air	>3.7	mm
CPG	External creepage ⁽¹⁾	Side 1 to side 2 distance across package surface	>3.7	mm
DTI	Distance through the insulation	Minimum internal gap (internal clearance)	>17	μm
CTI	Comparative tracking index	IEC 60112; UL 746A	>600	V
	Material Group	According to IEC 60664-1	I	
	Overvoltage category	Rated mains voltage ≤ 300 V _{RMS}	I-III	
DIN VDE V 0884-11:2017-01⁽²⁾				
V _{IORM}	Maximum repetitive peak isolation voltage	AC voltage (bipolar)	566	V _{PK}
V _{IOWM}	Maximum isolation working voltage	AC voltage (sine wave); time-dependent dielectric breakdown (TDDb) test;	400	V _{RMS}
		DC voltage	566	V _{DC}
V _{IOTM}	Maximum transient isolation voltage	V _{TEST} = V _{IOTM} , t = 60 s (qualification); V _{TEST} = 1.2 × V _{IOTM} , t = 1 s (100% production)	4242	V _{PK}
V _{IOSM}	Maximum surge isolation voltage ISO1500 ⁽³⁾	Test method per IEC 62368-1, 1.2/50 μs waveform, V _{TEST} = 10000 V _{PK} (qualification)	4000	V _{PK}
q _{pd}	Apparent charge ⁽⁴⁾	Method a: After I/O safety test subgroup 2/3, V _{ini} = V _{IOTM} , t _{ini} = 60 s; V _{pd(m)} = 1.2 × V _{IORM} , t _m = 10 s	≤ 5	pC
		Method a: After environmental tests subgroup 1, V _{ini} = V _{IOTM} , t _{ini} = 60 s; V _{pd(m)} = 1.6 × V _{IORM} , t _m = 10 s	≤ 5	
		Method b1: At routine test (100% production) and preconditioning (type test), V _{ini} = V _{IOTM} , t _{ini} = 1 s; V _{pd(m)} = 1.875 × V _{IORM} , t _m = 1 s	≤ 5	
C _{IO}	Barrier capacitance, input to output ⁽⁵⁾	V _{IO} = 0.4 × sin(2 πft), f = 1 MHz	~1	pF
R _{IO}	Insulation resistance, input to output ⁽⁵⁾	V _{IO} = 500 V, T _A = 25°C	> 10 ¹²	Ω
		V _{IO} = 500 V, 100°C ≤ T _A ≤ 150°C	> 10 ¹¹	
		V _{IO} = 500 V at T _S = 150°C	> 10 ⁹	
	Pollution degree		2	
	Climatic category		40/125/21	
UL 1577				
V _{ISO}	Withstand isolation voltage	V _{TEST} = V _{ISO} , t = 60 s (qualification); V _{TEST} = 1.2 × V _{ISO} , t = 1 s (100% production)	3000	V _{RMS}

- (1) Creepage and clearance requirements should be applied according to the specific equipment isolation standards of an application. Care should be taken to maintain the creepage and clearance distance of a board design to ensure that the mounting pads of the isolator on the printed-circuit board do not reduce this distance. Creepage and clearance on a printed-circuit board become equal in certain cases. Techniques such as inserting grooves, ribs, or both on a printed circuit board are used to help increase these specifications.
- (2) ISO1500 is suitable for safe *electrical insulation* within the safety ratings. Compliance with the safety ratings shall be ensured by means of suitable protective circuits.
- (3) Testing is carried out in air or oil to determine the intrinsic surge immunity of the isolation barrier.
- (4) Apparent charge is electrical discharge caused by a partial discharge (pd).
- (5) All pins on each side of the barrier tied together creating a two-pin device.

6.7 Safety-Related Certifications

VDE	CSA	UL	CQC	TUV
Certified according to DIN VDE V 0884-11:2017- 01	Certified according to IEC 60950-1, IEC 62368-1	Recognized under UL 1577 Component Recognition Program	Certified according to GB4943.1-2011	Certified according to EN 61010-1:2010/A1:2019, EN 60950-1:2006/A2:2013 and EN 62368-1:2014
Maximum transient isolation voltage, 4242 V _{PK} ; Maximum repetitive peak isolation voltage, 566 V _{PK} ; Maximum surge isolation voltage, 4000 V _{PK}	CSA 60950-1-07+A1+A2, IEC 60950-1 2nd Ed.+A1+A2, CSA 62368-1-14, and IEC 62368-1 2nd Ed., for pollution degree 2, material group I: 370 V _{RMS}	Single protection, 3000 V _{RMS}	Basic insulation, Altitude ≤ 5000 m, Tropical Climate, 400 V _{RMS} maximum working voltage	EN 61010-1:2010/A1:2019, 300 V _{RMS} basic isolation ----- EN 60950-1:2006/A2:2013 and EN 62368-1:2014, 400 V _{RMS} basic isolation
Certificate number: 40040142	Master contract number: 220991	File number: E181974	Certificate number: CQC18001199097	Client ID number: 77311

6.8 Safety Limiting Values

Safety limiting⁽¹⁾ intends to minimize potential damage to the isolation barrier upon failure of input or output circuitry.

PARAMETER		TEST CONDITIONS	MIN	TYP	MAX	UNIT
DBQ-16 PACKAGE						
I _S	Safety input, output, or supply current	R _{θJA} = 67.9°C/W, V _I = 5.5 V, T _J = 150°C, T _A = 25°C, see Figure 1			201	mA
		R _{θJA} = 67.9°C/W, V _I = 3.6 V, T _J = 150°C, T _A = 25°C, see Figure 1			308	
		R _{θJA} = 67.9°C/W, V _I = 2.75 V, T _J = 150°C, T _A = 25°C, see Figure 1			403	
		R _{θJA} = 67.9°C/W, V _I = 1.89 V, T _J = 150°C, T _A = 25°C, see Figure 1			586	
P _S	Safety input, output, or total power	R _{θJA} = 67.9°C/W, T _J = 150°C, T _A = 25°C, see Figure 2			1105	mW
T _S	Maximum safety temperature				150	°C

- (1) The maximum safety temperature, T_S, has the same value as the maximum junction temperature, T_J, specified for the device. The I_S and P_S parameters represent the safety current and safety power respectively. The maximum limits of I_S and P_S should not be exceeded. These limits vary with the ambient temperature, T_A.

The junction-to-air thermal resistance, R_{θJA}, in the table is that of a device installed on a high-K test board for leaded surface-mount packages. Use these equations to calculate the value for each parameter:

$$T_J = T_A + R_{\theta JA} \times P, \text{ where } P \text{ is the power dissipated in the device.}$$

$$T_{J(max)} = T_S = T_A + R_{\theta JA} \times P_S, \text{ where } T_{J(max)} \text{ is the maximum allowed junction temperature.}$$

$$P_S = I_S \times V_I, \text{ where } V_I \text{ is the maximum input voltage.}$$

6.9 Electrical Characteristics: Driver

Typical specs are at $V_{CC1}=3.3V$, $V_{CC2}=5V$, $T_A=27^\circ C$ (Min/Max specs are over recommended operating conditions unless otherwise noted)

PARAMETER		TEST CONDITIONS	MIN	TYP	MAX	UNIT
V _{OD}	Driver differential-output voltage magnitude	Open circuit voltage, unloaded bus, $4.5 V \leq V_{CC2} \leq 5.5 V$	1.5	4.3	V_{CC2}	V
		$R_L = 60 \Omega$, $-7 V \leq V_{TEST} \leq 12 V$, $4.5 V < V_{CC2} < 5.5 V$ (see Figure 19)	1.5	2.5		V
		$R_L = 100 \Omega$ (see Figure 20), RS-422 load	2	2.9		V
		$R_L = 54 \Omega$ (see Figure 20), RS-485 load, $4.5 V < V_{CC2} < 5.5 V$	1.5	2.5		V
$\Delta V_{OD} $	Change in differential output voltage between two states	$R_L = 54 \Omega$ or $R_L = 100 \Omega$, see Figure 20	-50		50	mV
V _{OC}	Common-mode output voltage	$R_L = 54 \Omega$ or $R_L = 100 \Omega$, see Figure 20		$0.5 \times V_{CC2}$	3	V
$\Delta V_{OC(SS)}$	change in steady-state common-mode output voltage between two states	$R_L = 54 \Omega$ or $R_L = 100 \Omega$, see Figure 20	-50		50	mV
V _{OC(PP)}	Peak-to-peak common-mode output voltage	$R_L = 54 \Omega$ or $R_L = 100 \Omega$, see Figure 20		300		mV
I _{OS}	Short-circuit output current	$V_D = V_{CC1}$ or $V_D = V_{GND1}$, $V_{DE} = V_{CC1}$, $-7 V \leq V_O \leq 12 V$, see Figure 28	-175		175	mA
I _i	Input current	V_D and $V_{DE} = 0 V$ or V_D and $V_{DE} = V_{CC1}$	-10		10	μA
CMTI	Common-mode transient immunity	$V_D = V_{CC1}$ or $GND1$, $V_{CM} = 1200V$, See Figure 22	85	100		kV/ μs

6.10 Electrical Characteristics: Receiver

Typical specs are at $V_{CC1}=3.3V$, $V_{CC2}=5V$, $T_A=27^\circ C$ (Min/Max are over recommended operating conditions unless otherwise noted)

PARAMETER		TEST CONDITIONS	MIN	TYP	MAX	UNIT
I _{i1}	Bus input current	$V_{DE} = 0 V$, $V_{CC2} = 0 V$ or $V_{CC2} = 5.5 V$, One bus input at $-7 V$ or $12 V$, other input at $0 V$	-100		100	μA
V _{TH+}	Positive-going input threshold voltage	$-7 V \leq$ Common mode voltage on bus terminals $\leq 12 V$	See ⁽¹⁾	-100	-50	mV
V _{TH-}	Negative-going input threshold voltage	$-7 V \leq$ Common mode voltage on bus terminals $\leq 12 V$	-200	-145	See ⁽¹⁾	mV
V _{hys}	Input hysteresis (V _{TH+} - V _{TH-})	$-7 V \leq$ Common mode voltage on bus terminals $\leq 12 V$	20	45		mV
V _{OH}	Output high voltage on the R pin	$V_{CC1}=5V \pm 10\%$, I _{OH} = -4 mA, V _{ID} = 200 mV	$V_{CC1} - 0.4$			V
		$V_{CC1}=3.3V \pm 10\%$, I _{OH} = -2 mA, V _{ID} = 200 mV	$V_{CC1} - 0.3$			V
		$V_{CC1}=2.5V \pm 10\%$, 1.8V \pm 5%, I _{OH} = -1 mA, V _{ID} = 200 mV	$V_{CC1} - 0.2$			V
V _{OL}	Output low voltage on the R pin	$V_{CC1}=5V \pm 10\%$, I _{OL} = 4 mA, V _{ID} = -200 mV			0.4	V
		$V_{CC1}=3.3V \pm 10\%$, I _{OL} = 2 mA, V _{ID} = -200 mV			0.3	V
		$V_{CC1}=2.5V \pm 10\%$, 1.8V \pm 5%, I _{OL} = 1 mA, V _{ID} = -200 mV			0.2	V
I _{OZ}	Output high-impedance current on the R pin	$V_R = 0 V$ or $V_R = V_{CC1}$, $\overline{V_{RE}} = V_{CC1}$	-1		1	μA
I _i	Input current on the \overline{RE} pin	$\overline{V_{RE}} = 0 V$ or $\overline{V_{RE}} = V_{CC1}$	-10		10	μA
CMTI	Common-mode transient immunity	$V_{ID} = 1.5 V$ or $-1.5 V$, $V_{CM} = 1200 V$, See Figure 22	85	100		kV/ μs

(1) Under any specific conditions, V_{TH+} is ensured to be at least V_{hys} higher than V_{TH-}.

6.11 Supply Current Characteristics: Side 1(I_{CC1})

Bus loaded or unloaded (over recommended operating conditions unless otherwise noted)

PARAMETER	TEST CONDITIONS	MIN	TYP	MAX	UNIT
DRIVER ENABLED, RECEIVER DISABLED					
Logic-side supply current	$V_D = V_{CC1}, V_{CC1} = 5\text{ V} \pm 10\%$		2.6	4.4	mA
Logic-side supply current	$V_D = V_{CC1}, V_{CC1} = 3.3\text{ V} \pm 10\%$		2.6	4.4	mA
Logic-side supply current	$D = 1\text{Mbps}$ square wave with 50% duty cycle, $V_{CC1} = 5\text{ V} \pm 10\%$		3.2	5.1	mA
Logic-side supply current	$D = 1\text{Mbps}$ square wave with 50% duty cycle, $V_{CC1} = 3.3\text{ V} \pm 10\%$		3.2	5.1	mA
DRIVER ENABLED, RECEIVER ENABLED					
Logic-side supply current	$V_{RE} = V_{GND1}, V_D = V_{CC1}, V_{CC1} = 5\text{ V} \pm 10\%$		2.6	4.4	mA
Logic-side supply current	$V_{RE} = V_{GND1}, V_D = V_{CC1}, V_{CC1} = 3.3\text{ V} \pm 10\%$		2.6	4.4	mA
Logic-side supply current	$V_{RE} = V_{GND1}, D = 1\text{Mbps}$ square wave with 50% duty cycle, $V_{CC1} = 5\text{ V} \pm 10\%$, $C_{L(R)}^{(1)} = 15\text{ pF}$		3.4	5.2	mA
Logic-side supply current	$V_{RE} = V_{GND1}, D = 1\text{Mbps}$ square wave with 50% duty cycle, $V_{CC1} = 3.3\text{ V} \pm 10\%$, $C_{L(R)}^{(1)} = 15\text{ pF}$		3.2	5.2	mA
DRIVER DISABLED, RECEIVER ENABLED					
Logic-side supply current	$V_{(A-B)} \geq 200\text{ mV}, V_D = V_{CC1}, V_{CC1} = 5\text{ V} \pm 10\%$		1.5	3.1	mA
Logic-side supply current	$V_{(A-B)} \geq 200\text{ mV}, V_D = V_{CC1}, V_{CC1} = 3.3\text{ V} \pm 10\%$		1.5	3.1	mA
Logic-side supply current	$(A-B) = 1\text{Mbps}$ square wave with 50% duty cycle, $V_D = V_{CC1}, V_{CC1} = 5\text{ V} \pm 10\%$, $C_{L(R)}^{(1)} = 15\text{ pF}$		1.7	3.2	mA
Logic-side supply current	$(A-B) = 1\text{Mbps}$ square wave with 50% duty cycle, $V_D = V_{CC1}, V_{CC1} = 3.3\text{ V} \pm 10\%$, $C_{L(R)}^{(1)} = 15\text{ pF}$		1.7	3.2	mA
DRIVER DISABLED, RECEIVER DISABLED					
Logic-side supply current	$V_{DE} = V_{GND1}, V_D = V_{CC1}, V_{CC1} = 5\text{ V} \pm 10\%$		1.5	3.1	mA
Logic-side supply current	$V_{DE} = V_{GND1}, V_D = V_{CC1}, V_{CC1} = 3.3\text{ V} \pm 10\%$		1.5	3.1	mA

(1) $C_{L(R)}$ is the load capacitance on the R pin.

6.12 Supply Current Characteristics: Side 2(I_{CC2})

$V_{RE} = V_{GND1}$ or $V_{RE} = V_{CC1}$ (over recommended operating conditions unless otherwise noted)

PARAMETER	TEST CONDITIONS	MIN	TYP	MAX	UNIT
DRIVER ENABLED, BUS UNLOADED					
Bus-side supply current	$V_D = V_{CC1}, V_{CC2} = 5\text{ V} \pm 10\%$		2.5	4.4	mA
DRIVER ENABLED, BUS LOADED					
Bus-side supply current	$V_D = V_{CC1}, R_L = 54\ \Omega, V_{CC2} = 5\text{ V} \pm 10\%$		52	70	mA
Bus-side supply current	$D = 1\text{Mbps}$ square wave with 50% duty cycle, $R_L = 54\ \Omega, C_L = 50\text{ pF}, V_{CC2} = 5\text{ V} \pm 10\%$		60	80	mA
DRIVER DISABLED, BUS LOADED OR UNLOADED					
Bus-side supply current	$V_D = V_{CC1}, V_{CC2} = 5\text{ V} \pm 10\%$		2.4	3.9	mA

6.13 Switching Characteristics: Driver

Typical specs are at $V_{CC1}=3.3V$, $V_{CC2}=5V$, $T_A=27^\circ C$ (Min/Max specs over recommended operating conditions unless otherwise noted)

PARAMETER		TEST CONDITIONS	MIN	TYP	MAX	UNIT
1Mbps DEVICE						
t_r, t_f	Differential output rise time and fall time	$R_L = 54 \Omega, C_L = 50 \text{ pF}$, see Figure 21		210	300	ns
t_{PHL}, t_{PLH}	Propagation delay	$R_L = 54 \Omega, C_L = 50 \text{ pF}$, see Figure 21		210	300	ns
PWD	Pulse width distortion ⁽¹⁾ , $ t_{PHL} - t_{PLH} $	$R_L = 54 \Omega, C_L = 50 \text{ pF}$, see Figure 21		3	30	ns
t_{PHZ}, t_{PLZ}	Disable time	See Figure 23 , and Figure 24		160	250	ns
t_{PZH}, t_{PZL}	Enable time	See Figure 23 , and Figure 24		200	400	ns

(1) Also known as pulse skew.

6.14 Switching Characteristics: Receiver

Typical specs are at $V_{CC1}=3.3V$, $V_{CC2}=5V$, $T_A=27^\circ C$ (Min/Max are over recommended operating conditions unless otherwise noted)

PARAMETER		TEST CONDITIONS	MIN	TYP	MAX	UNIT
1Mbps DEVICE						
t_r, t_f	Differential output rise time and fall time	$C_L = 15 \text{ pF}$, see Figure 25		2.4	4	ns
t_{PHL}, t_{PLH}	Propagation delay	$C_L = 15 \text{ pF}$, see Figure 25		120	180	ns
PWD	Pulse width distortion ⁽¹⁾ , $ t_{PHL} - t_{PLH} $	$C_L = 15 \text{ pF}$, see Figure 25		5	20	ns
t_{PHZ}, t_{PLZ}	Disable time	See Figure 26 and Figure 27		11	30	ns
t_{PZH}, t_{PZL}	Enable time	See Figure 26 and Figure 27		7	20	ns

(1) Also known as pulse skew.

6.15 Insulation Characteristics Curves

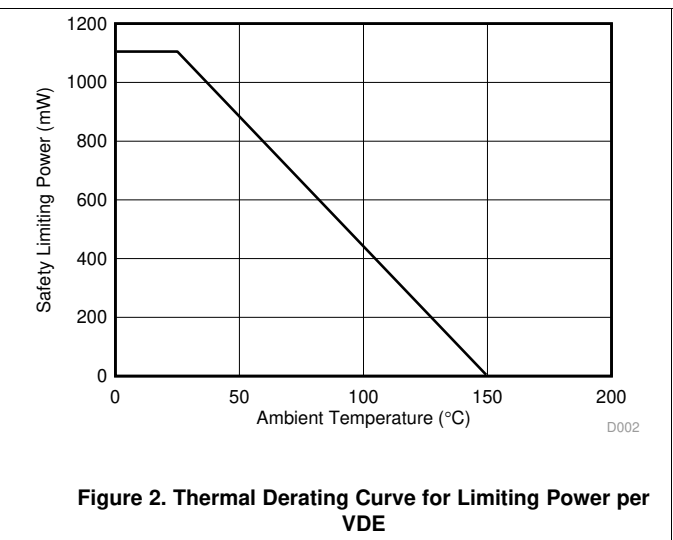
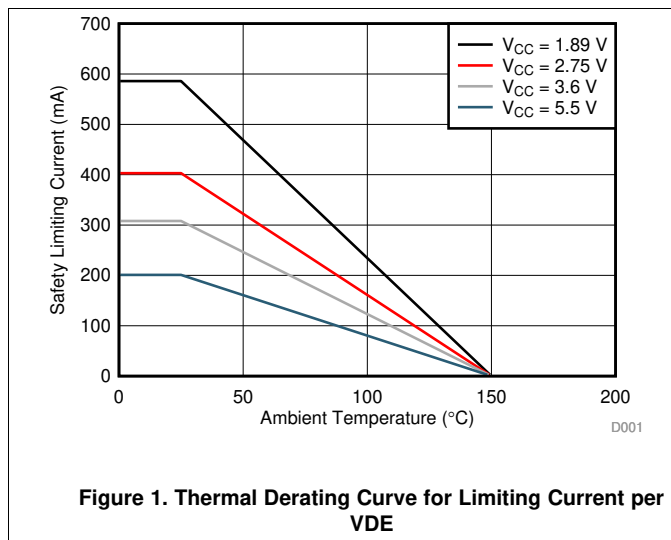

6.16 Typical Characteristics

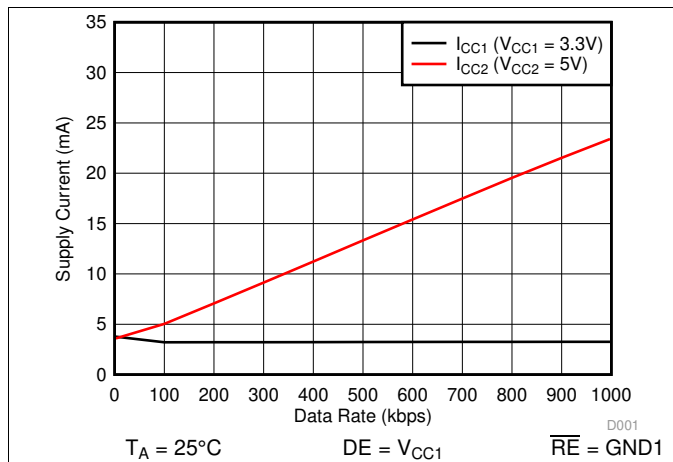

Figure 3. Supply Current Vs Data Rate- No Load

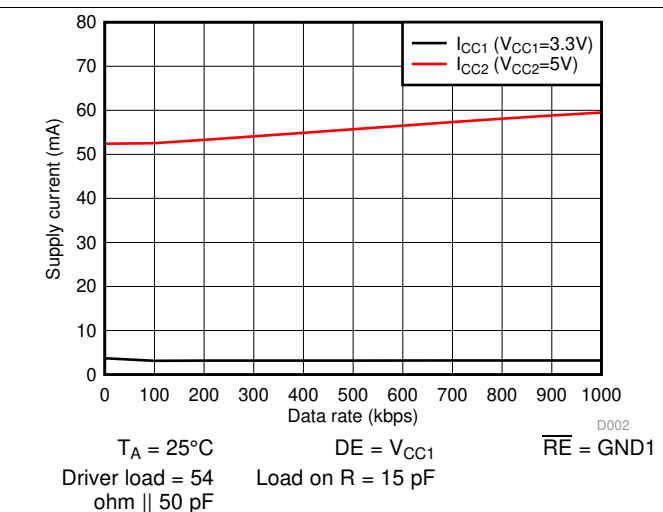

Figure 4. Supply Current Vs Data Rate- with 54 Ω || 50 pf Load

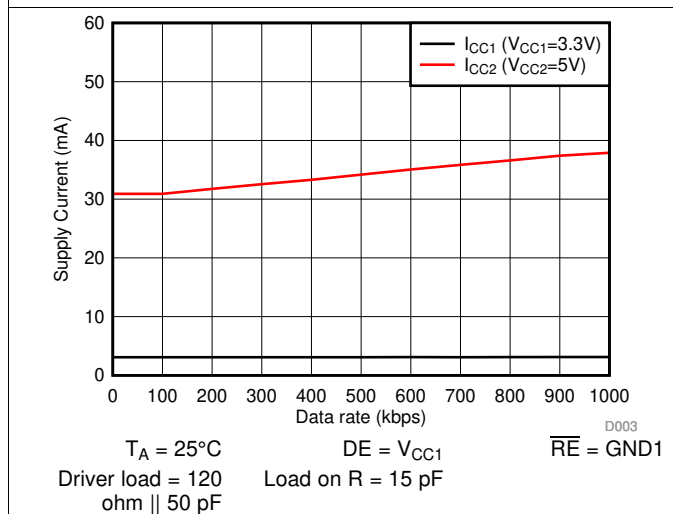

Figure 5. Supply Current Vs Data Rate - with 120 Ω || 50 pf Load

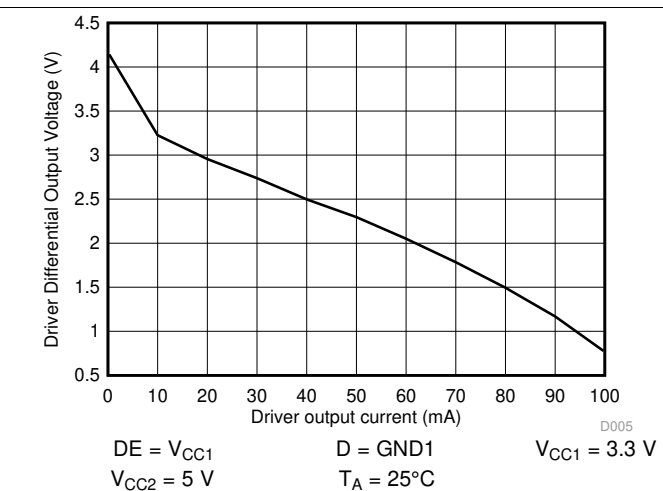
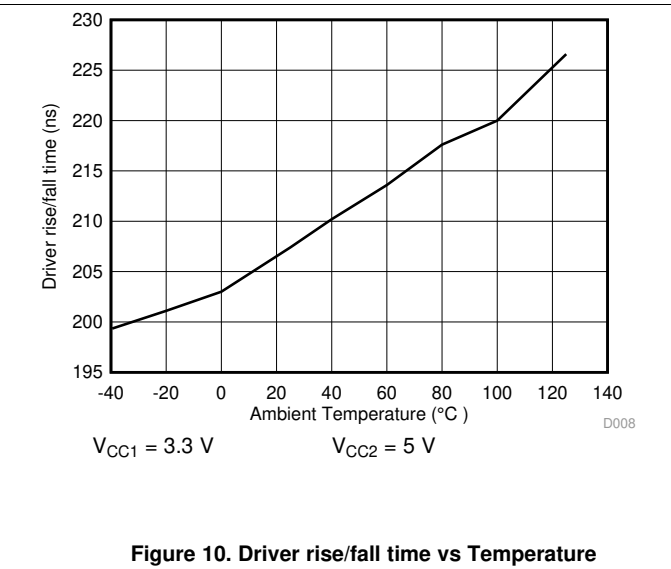
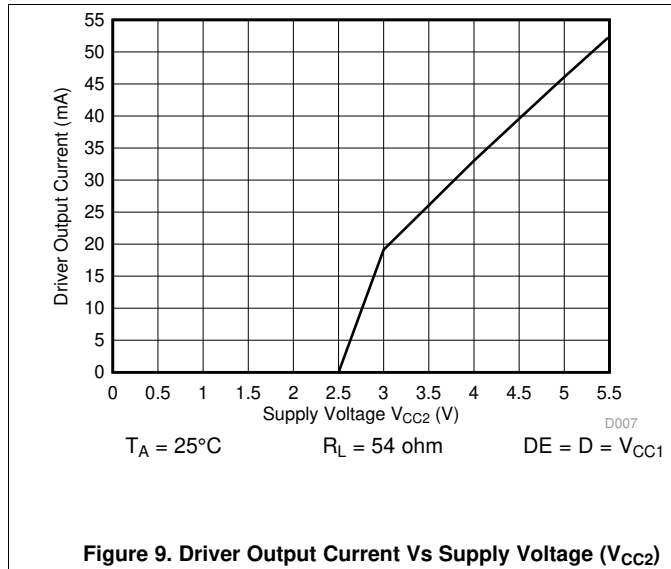
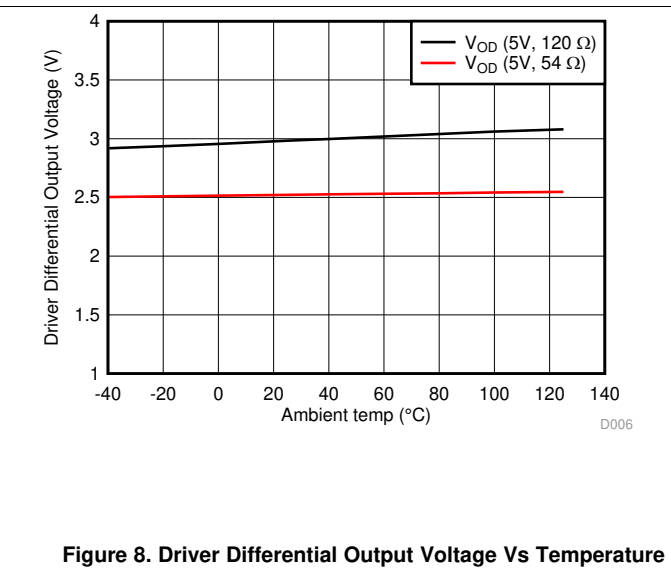
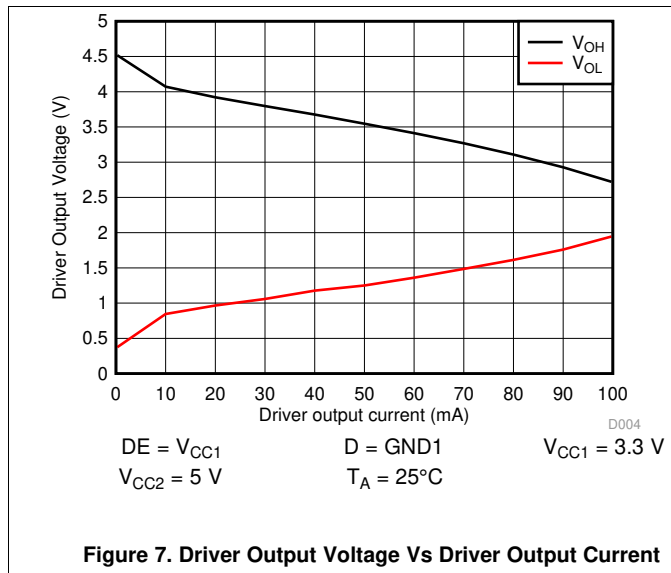
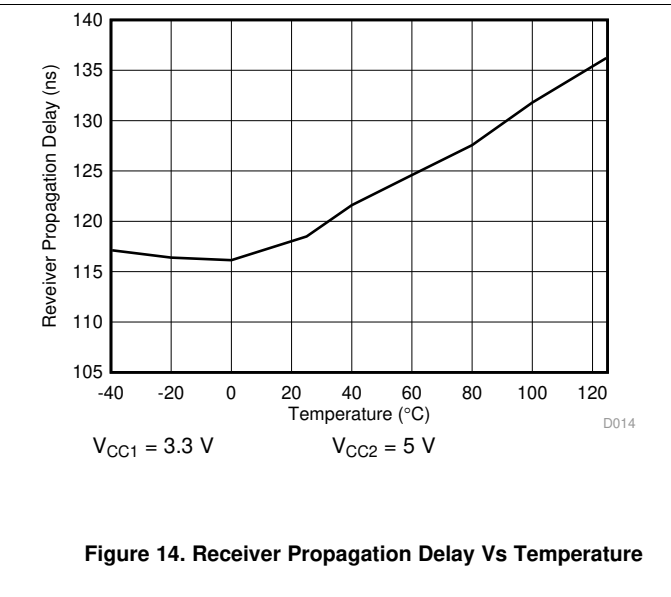
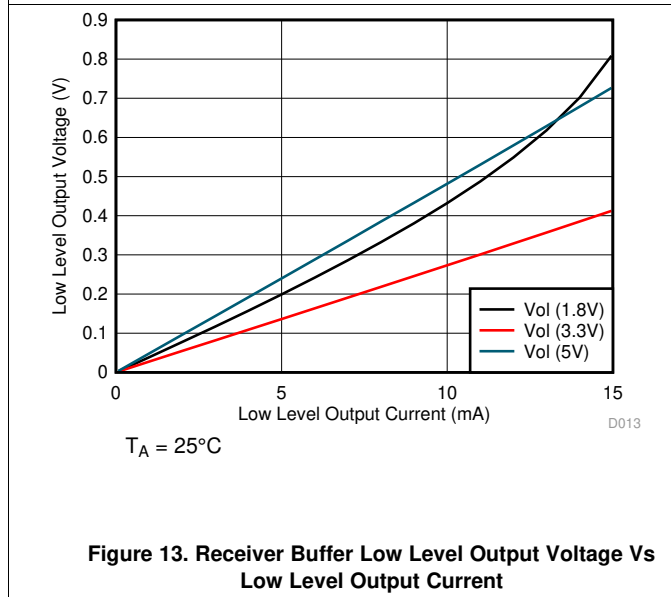
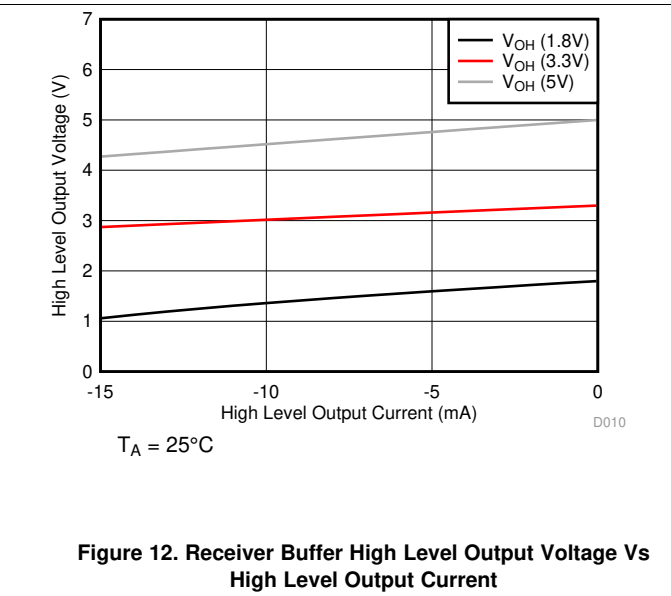
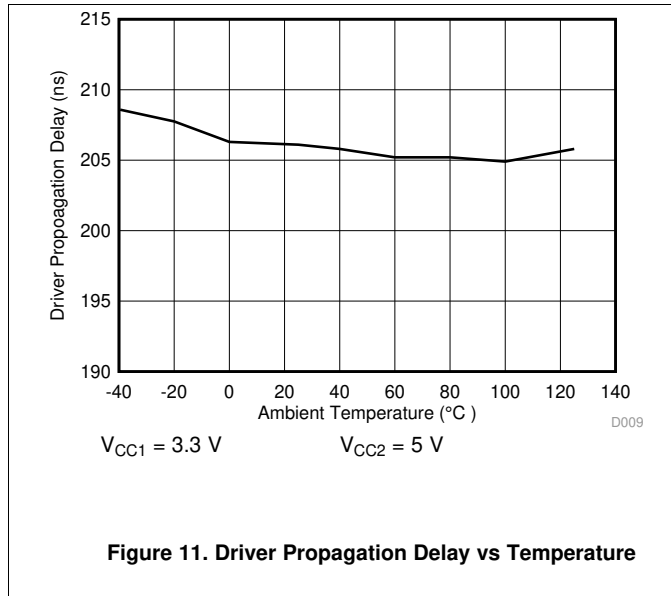

Figure 6. Driver Differential Output Voltage Vs Driver Output Current

Typical Characteristics (continued)



Typical Characteristics (continued)



Typical Characteristics (continued)

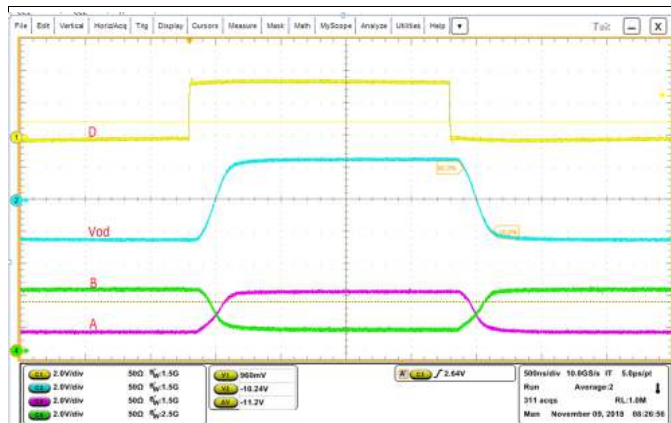

$V_{CC1} = 3.3\text{ V}$ $V_{CC2} = 5\text{ V}$ $DE = V_{CC1}$
 $T_A = 25^\circ\text{C}$

Figure 15. Driver Propagation delay



$V_{CC1} = 3.3\text{ V}$ $V_{CC2} = 5\text{ V}$ $T_A = 25^\circ\text{C}$
 $DE = GND1$ $\overline{RE} = GND1$

Figure 16. Receiver Propagation Delay

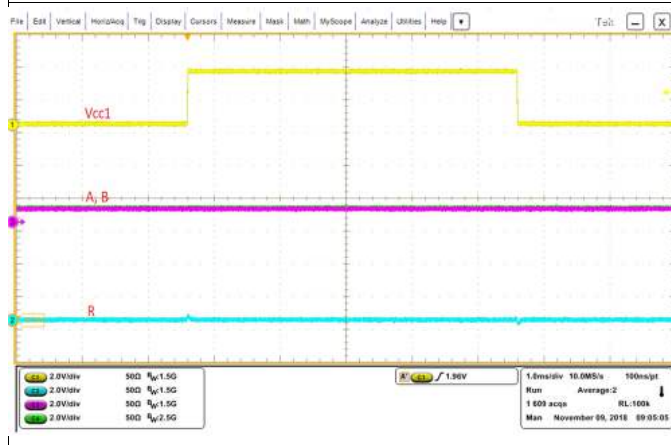

Figure 17. V_{CC1} Power Up / Power down- Glitch Free Behavior

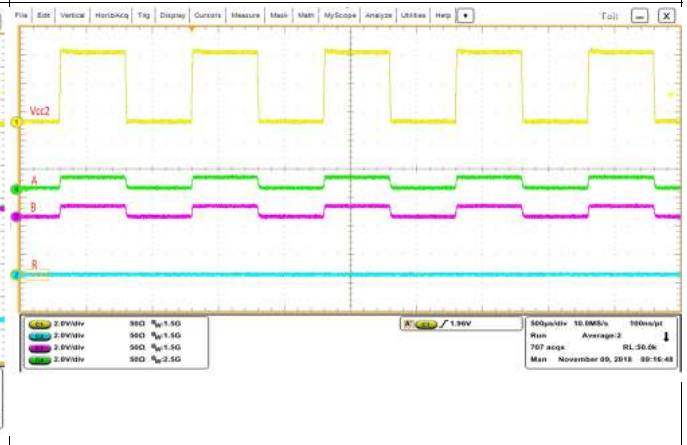

Figure 18. V_{CC2} Power Up / Power down- Glitch Free Behavior

7 Parameter Measurement Information

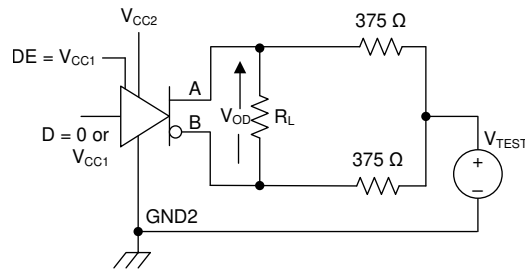
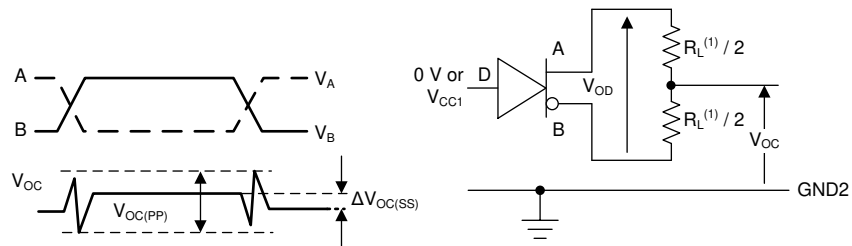
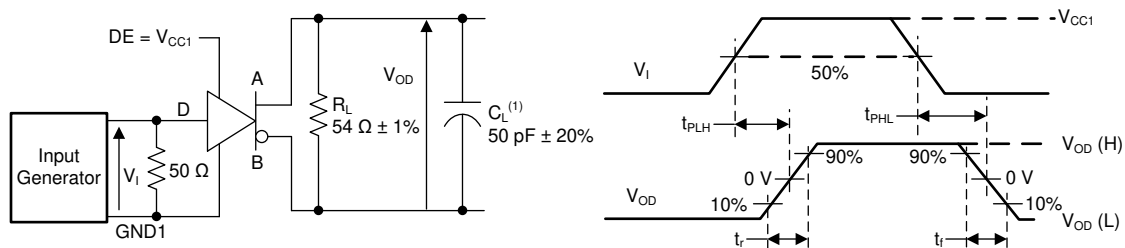

Figure 19. Driver Voltages



(1) $R_L = 100 \Omega$ for RS422, $R_L = 54 \Omega$ for RS-485

Figure 20. Driver Voltages



(1) C_L includes fixture and instrumentation capacitance.

Figure 21. Driver Switching Specifications

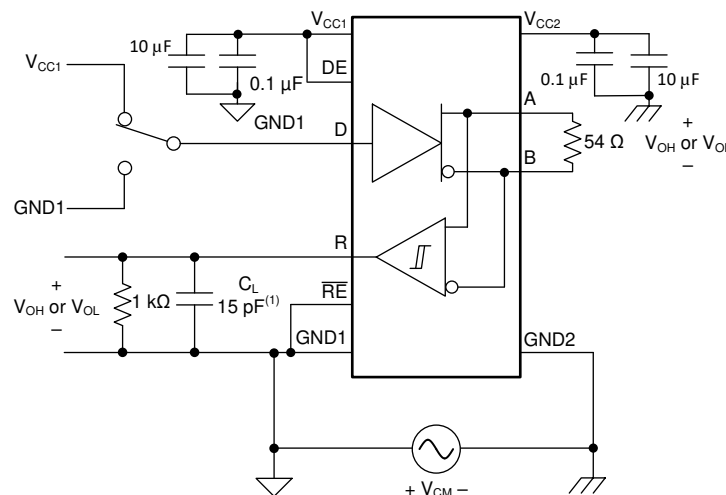

(1) Includes probe and fixture capacitance.

Figure 22. Common Mode Transient Immunity (CMTI)—Half Duplex

Parameter Measurement Information (continued)

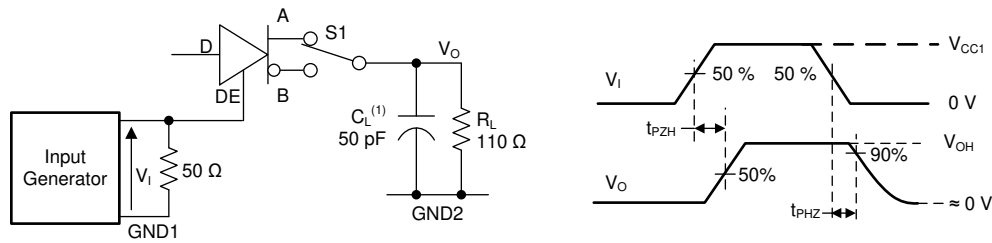

(1) C_L includes fixture and instrumentation capacitance

Figure 23. Driver Enable and Disable Times

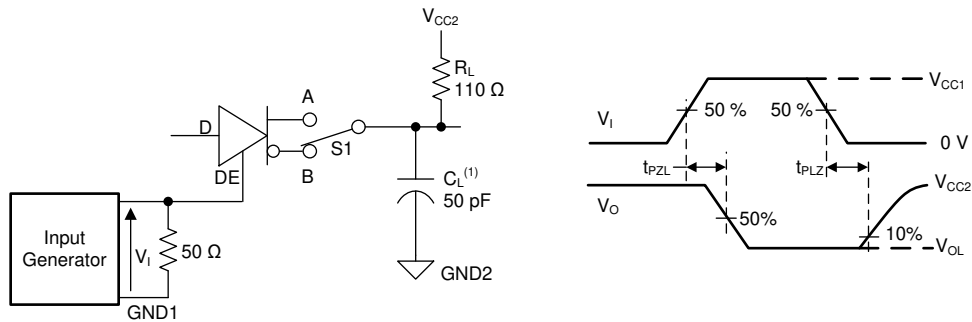
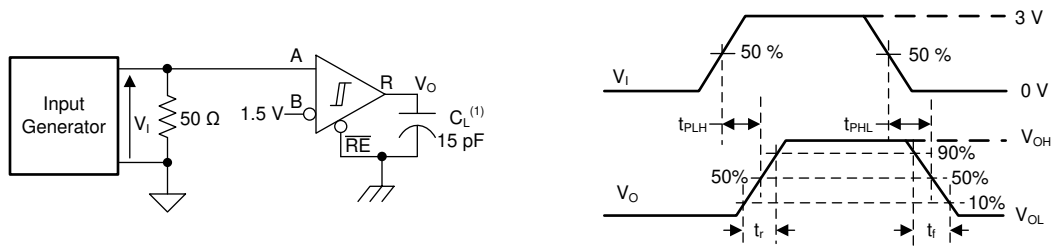

Figure 24. Driver Enable and Disable Times



(1) C_L includes fixture and instrumentation capacitance.

Figure 25. Receiver Switching Specifications

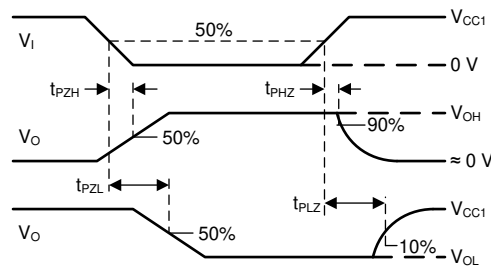

Figure 26. Receiver Enable and Disable Times

Parameter Measurement Information (continued)

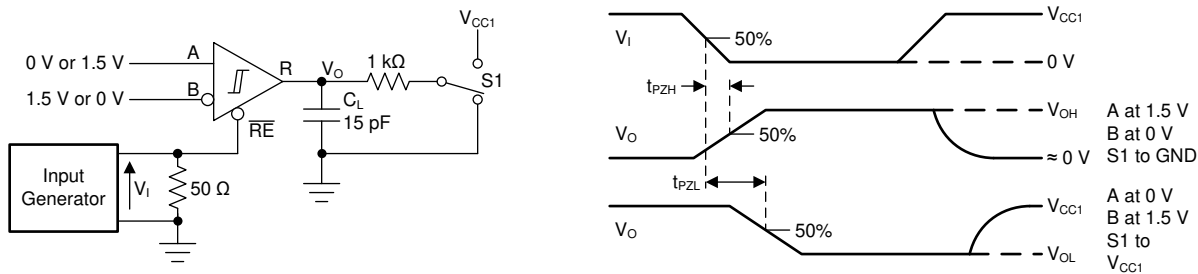
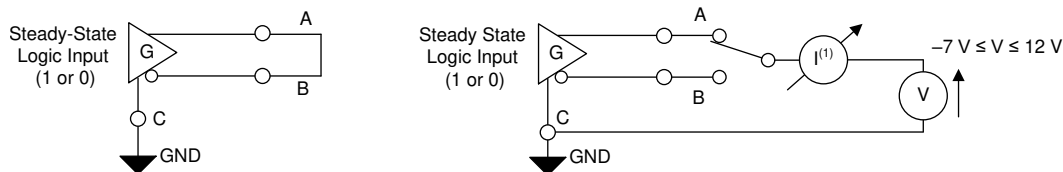

Figure 27. Receiver Enable and Disable Times



(1) The driver should not sustain any damage with this configuration.

Figure 28. Short-Circuit Current Limiting

8 Detailed Description

8.1 Overview

The ISO1500 device is an isolated RS-485/RS-422 transceiver designed to operate in harsh industrial environments. This device supports data transmissions up to 1 Mbps. The ISO1500 device has a 3-channel digital isolator and an RS-485 transceiver in an ultra-small SSOP package. The silicon-dioxide based capacitive isolation barrier supports an isolation withstand voltage of 3 kV_{RMS} and an isolation working voltage of 566 V_{PK}. Isolation breaks the ground loop between the communicating nodes and lets data transfer in the presence of large ground potential differences. The wide logic supply of the device (V_{CC1}) supports interfacing with 1.8-V, 2.5-V, 3.3-V, and 5-V control logic. [Functional Block Diagram](#) shows the functional block diagram of the the half-duplex device.

8.2 Functional Block Diagram

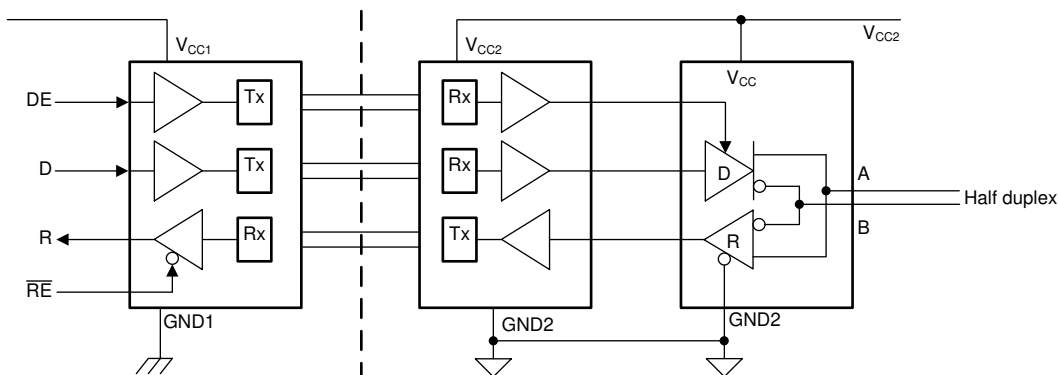

8.3 Feature Description

[Table 1](#) shows an overview of the device features.

Table 1. Device Features

PART NUMBER	ISOLATION	DUPLEX	DATA RATE	PACKAGE
ISO1500	Basic	Half	1 Mbps	16-pin SSOP

8.3.1 Electromagnetic Compatibility (EMC) Considerations

Many applications in harsh industrial environment are sensitive to disturbances such as electrostatic discharge (ESD), electrical fast transient (EFT), surge and electromagnetic emissions. These electromagnetic disturbances are regulated by international standards such as IEC 61000-4-x and CISPR 22. Although system-level performance and reliability depends, to a large extent, on the application board design and layout, the ISO1500 device has dedicated circuitry to help protect the transceiver from Contact ESD per IEC61000-4-2.

8.3.2 Failsafe Receiver

The differential receiver of the ISO1500 device has failsafe protection from invalid bus states caused by:

- Open bus conditions such as a broken cable or a disconnected connector
- Shorted bus conditions such as insulation breakdown of a cable that shorts the twisted-pair
- Idle bus conditions that occur when no driver on the bus is actively driving

The differential input of the RS-485 receiver is 0 in any of these conditions for a terminated transmission line. The receiver outputs a failsafe logic-high state so that the output of the receiver is not indeterminate.

The receiver thresholds are offset in the receiver failsafe protection so that the indeterminate range of the input does not include a 0 V differential. The receiver output must generate a logic high when the differential input (V_{ID}) is greater than 200 mV to comply with the RS-485 standard. The receiver output must also generate a output a logic low when V_{ID} is less than -200 mV to comply with the RS-485 standard. The receiver parameters that determine the failsafe performance are V_{TH+} , V_{TH-} , and V_{HYS} . Differential signals less than -200 mV always cause a low receiver output as shown in the *Electrical Characteristics* table. Differential signals greater than 200 mV always cause a high receiver output. A differential input signal that is near zero is still greater than the V_{TH+} threshold which makes the receiver output logic high. The receiver output goes to a low state only when the differential input decreases by V_{HYS} to less than V_{TH+} .

The internal failsafe biasing feature removes the need for the two external resistors that are typically required with traditional isolated RS-485 transceivers as shown in Figure 29.

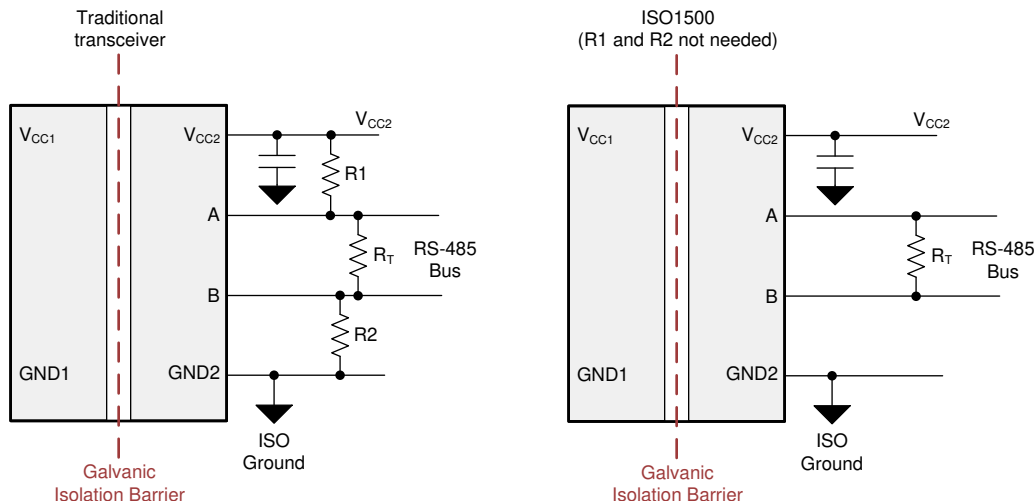

Figure 29. Failsafe Transceiver

8.3.3 Thermal Shutdown

The ISO1500 device has a thermal shutdown circuit to protect against damage when a fault condition occurs. A driver output short circuit or bus contention condition can cause the driver current to increase significantly which increases the power dissipation inside the device. An increase in the die temperature is monitored and the device is disabled when the die temperature becomes 170°C (typical) which lets the device decrease the temperature. The device is enabled when the junction temperature becomes 163°C (typical).

8.3.4 Glitch-Free Power Up and Power Down

Communication on the bus that already exist between a master node and slave node in an RS485 network must not be disturbed when a new node is swapped in or out of the network. No glitches on the bus occur when the device is:

- Hot plugged into the network in an unpowered state
- Hot plugged into the network in a powered state and disabled state
- Powered up or powered down in a disabled state when already connected to the bus

The ISO1500 device does not cause any false data toggling on the bus when powered up or powered down in a disabled state with supply ramp rates from 100 µs to 10 ms.

8.4 Device Functional Modes

Table 2 shows the driver functional modes.

Table 2. Driver Functional Table⁽¹⁾

V _{CC1}	V _{CC2}	INPUT D	DRIVER ENABLE DE	OUTPUTS	
				A	B
PU	PU	H	H	H	L
		L	H	L	H
		X	L	Hi-Z	Hi-Z
		X	Open	Hi-Z	Hi-Z
		Open	H	H	L
PD ⁽²⁾	PU	X	X	Hi-Z	Hi-Z
X	PD	X	X	Hi-Z	Hi-Z

- (1) PU = Powered Up; PD = Powered Down; H = High Level; L = Low level; X = Irrelevant, Hi-Z = High impedance state
- (2) A strongly driven input signal can weakly power the floating V_{CC1} through an internal protection diode and cause an undetermined output.

When the driver enable pin, DE, is logic high, the differential outputs, A and B, follow the logic states at data input, D. A logic high at the D input causes the A output to go high and the B output to go low. Therefore the differential output voltage defined by Equation 1 is positive.

$$V_{OD} = V_A - V_B \tag{1}$$

A logic low at the D input causes the B output to go high and the A output to go low. Therefore the differential output voltage defined by Equation 1 is negative. A logic low at the DE input causes both outputs to go to the high-impedance (Hi-Z) state. The logic state at the D pin is irrelevant when the DE input is logic low. The DE pin has an internal pulldown resistor to ground. The driver is disabled (bus outputs are in the Hi-Z) by default when the DE pin is left open. The D pin has an internal pullup resistor. The A output goes high and the B output goes low when the D pin is left open while the driver enabled.

Table 3 shows the receiver functional modes.

Table 3. Receiver Functional Table⁽¹⁾

V _{CC1}	V _{CC2}	DIFFERENTIAL INPUT	RECEIVER ENABLE \overline{RE}	OUTPUT R
		$V_{ID} = V_A - V_B$		
PU	PU	$-0.02\text{ V} \leq V_{ID}$	L	H
		$-0.2\text{ V} < V_{ID} < 0.02\text{ V}$	L	Indeterminate
		$V_{ID} \leq -0.2\text{ V}$	L	L
		X	H	Hi-Z
		X	Open	Hi-Z
		Open, Short, Idle	L	H
PD ⁽²⁾	PU	X	X	Hi-Z
PU	PD	X	L	H
PD ⁽²⁾	PD	X	X	Hi-Z

- (1) PU = Powered Up; PD = Powered Down; H = Logic High; L = Logic Low; X = Irrelevant, Hi-Z = High Impedance (OFF) state
- (2) A strongly driven input signal can weakly power the floating V_{CC1} through an internal protection diode and cause an undetermined output.

The receiver is enabled when the receiver enable pin, \overline{RE} , is logic low. The receiver output, R, goes high when the differential input voltage defined by Equation 2 is greater than the positive input threshold, V_{TH+} .

$$V_{ID} = V_A - V_B \quad (2)$$

The receiver output, R, goes low when the differential input voltage defined by Equation 2 is less than the negative input threshold, V_{TH-} . If the V_{ID} voltage is between the V_{TH+} and V_{TH-} thresholds, the output is indeterminate. The receiver output is in the Hi-Z state and the magnitude and polarity of V_{ID} are irrelevant when the \overline{RE} pin is logic high or left open. The internal biasing of the receiver inputs causes the output to go to a failsafe-high when the transceiver is disconnected from the bus (open-circuit), the bus lines are shorted to one another (short-circuit), or the bus is not actively driven (idle bus).

8.4.1 Device I/O Schematics

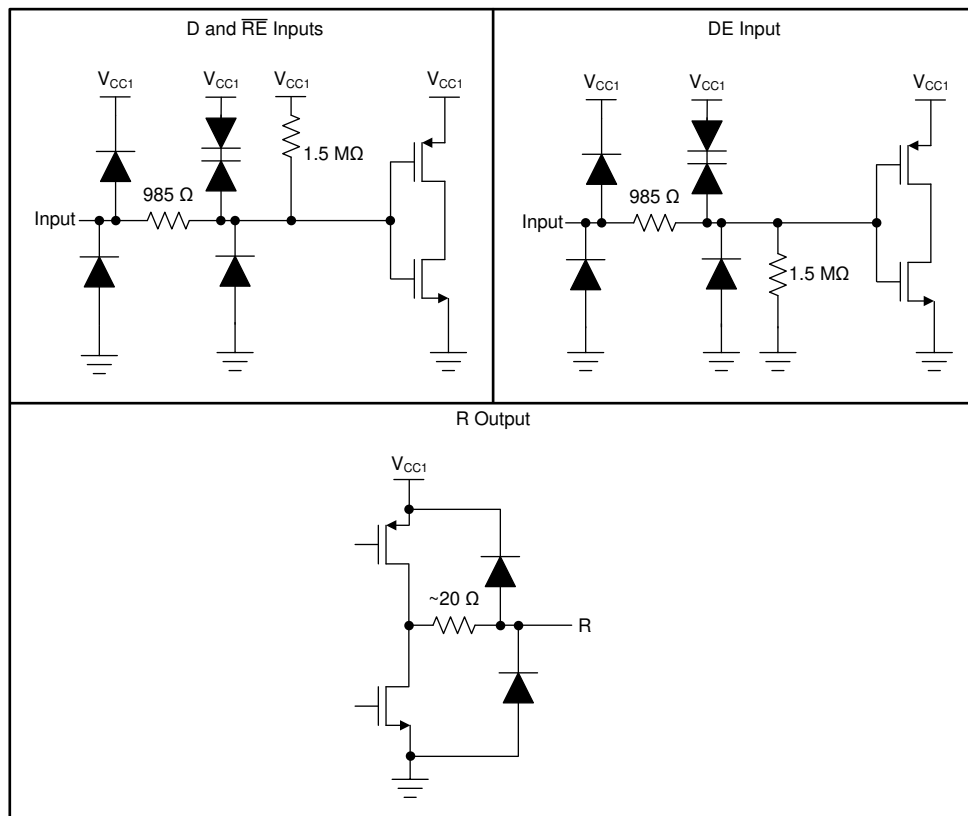

Figure 30. Device I/O Schematics

9 Application and Implementation

NOTE

Information in the following applications sections is not part of the TI component specification, and TI does not warrant its accuracy or completeness. TI's customers are responsible for determining suitability of components for their purposes. Customers should validate and test their design implementation to confirm system functionality.

9.1 Application Information

The ISO1500 device is designed for bidirectional data transfer on multipoint RS-485 networks. The design of each RS-485 node in the network requires an ISO1500 device and an isolated power supply as shown in Figure 32.

An RS-485 bus has multiple transceivers that connect in parallel to a bus cable. Both cable ends are terminated with a termination resistor, R_T , to remove line reflections. The value of R_T matches the characteristic impedance, Z_0 , of the cable. This method, known as parallel termination, lets higher data rates be used over a longer cable length.

In half-duplex implementation, as shown in Figure 31, the driver and receiver enable pins let any node at any given moment be configured in either transmit or receive mode which decreases cable requirements.

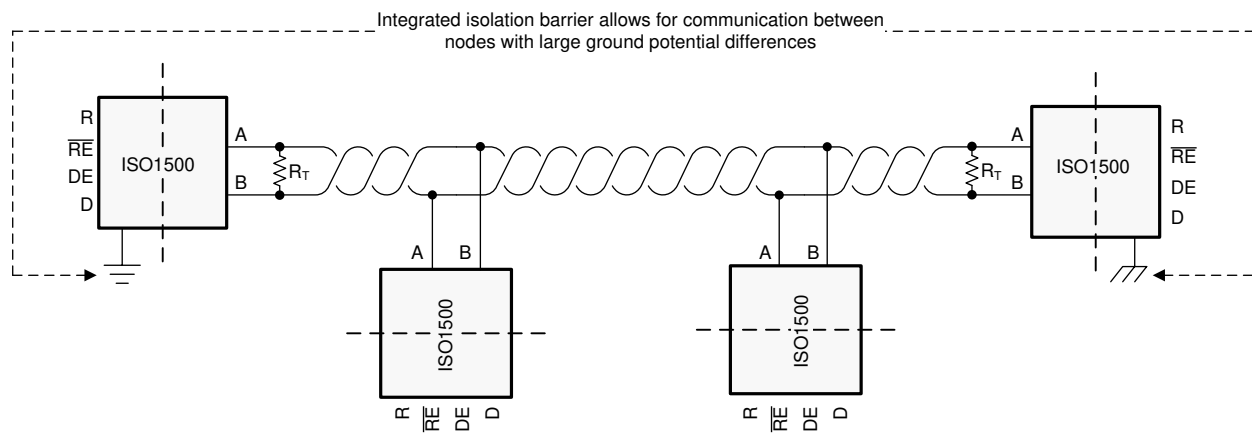

Figure 31. Half-Duplex Network Circuit

9.2 Typical Application

Figure 32 shows the application circuit of the ISO1500 device.

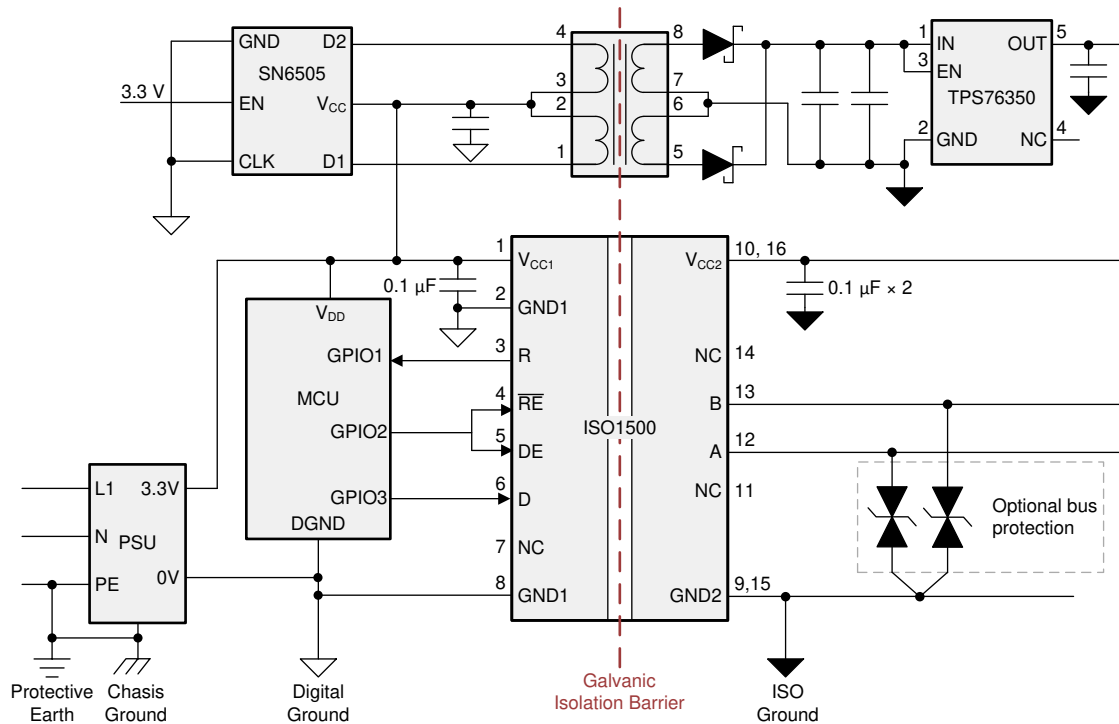

Figure 32. Typical Application

9.2.1 Design Requirements

Unlike an optocoupler-based solution, which requires several external components to improve performance, provide bias, or limit current, the ISO1500 device only requires external bypass capacitors to operate.

9.2.2 Detailed Design Procedure

The RS-485 bus is a robust electrical interface suitable for long-distance communications. The RS-485 interface can be used in a wide range of applications with varying requirements of distance of communication, data rate, and number of nodes.

9.2.2.1 Data Rate and Bus Length

The RS-485 standard has typical curves similar to those shown in Figure 33. These curves show the inverse relationship between signaling rate and cable length. If the data rate of the payload between two nodes is lower, the cable length between the nodes can be longer.

Typical Application (continued)

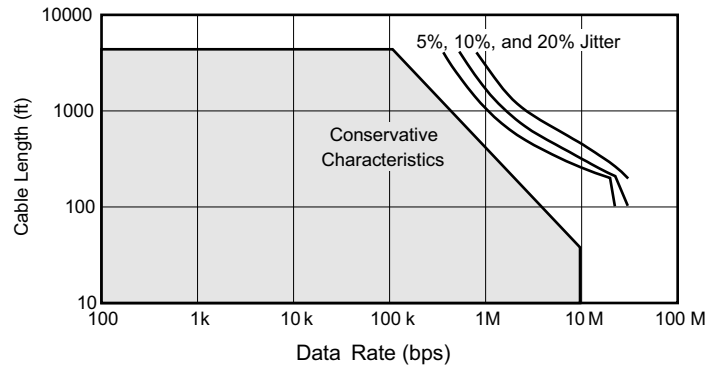

Figure 33. Cable Length vs Data Rate Characteristics

Applications can increase the cable length at slower data rates compared to what is shown in [Figure 33](#) by allowing for jitter of 5% or higher. Use [Figure 33](#) as a guideline for cable selection, data rate, cable length and subsequent jitter budgeting.

9.2.2.2 Stub Length

In an RS-485 network, the distance between the transceiver inputs and the cable trunk is known as the *stub*. The stub should be as short as possible when a node is connected to the bus. Stubs are a non-terminated piece of bus line that can introduce reflections of varying phase as the length of the stub increases. The electrical length, or round-trip delay, of a stub should be less than one-tenth of the rise time of the driver as a general guideline. Therefore, the maximum physical stub length ($L_{(STUB)}$) is calculated as shown in [Equation 3](#).

$$L_{(STUB)} \leq 0.1 \times t_r \times v \times c$$

where

- t_r is the 10/90 rise time of the driver.
- c is the speed of light (3×10^8 m/s).
- v is the signal velocity of the cable or trace as a factor of c .

(3)

9.2.2.3 Bus Loading

The current supplied by the driver must supply into a load because the output of the driver depends on this current. Add transceivers to the bus to increase the total bus loading. The RS-485 standard specifies a hypothetical term of a unit load (UL) to estimate the maximum number of possible bus loads. The UL represents a load impedance of approximately 12 k Ω . Standard-compliant drivers must be able to drive 32 of these ULs.

The ISO1500 device has 1/8 UL impedance transceiver and can connect up to 256 nodes to the bus.

10 Power Supply Recommendations

To make sure device operation is reliable at all data rates and supply voltages, a 0.1- μ F bypass capacitor is recommended at the logic and transceiver supply pins (V_{CC1} and V_{CC2}). The capacitors should be placed as near to the supply pins as possible. Side 2 requires one V_{CC2} decoupling capacitor on each V_{CC2} pin. If only one primary-side power supply is available in an application, isolated power can be generated for the secondary-side with the help of a transformer driver such as TI's [SN6505B](#) device. For such applications, detailed power supply design and transformer selection recommendations are available in the [SN6505 Low-Noise 1-A Transformer Drivers for Isolated Power Supplies](#) data sheet.

11 Layout

11.1 Layout Guidelines

A minimum of four layers is required to accomplish a low EMI PCB design (see [Figure 34](#)). Layer stacking should be in the following order (top-to-bottom): high-speed signal layer, ground plane, power plane and low-frequency signal layer.

- Routing the high-speed traces on the top layer avoids the use of vias (and the introduction of their inductances) and allows for clean interconnects between the isolator and the transmitter and receiver circuits of the data link.
- Placing a solid ground plane next to the high-speed signal layer establishes controlled impedance for transmission line interconnects and provides an excellent low-inductance path for the return current flow.
- Placing the power plane next to the ground plane creates additional high-frequency bypass capacitance of approximately 100 pF/in².
- Routing the slower speed control signals on the bottom layer allows for greater flexibility as these signal links usually have margin to tolerate discontinuities such as vias.

[Figure 35](#) shows the recommended placement and routing of the device bypass capacitors and optional TVS diodes. Put the two V_{CC2} bypass capacitors on the top layer and as near to the device pins as possible. Do not use vias to complete the connection to the V_{CC2} and GND2 pins. If an additional supply voltage plane or signal layer is needed, add a second power or ground plane system to the stack to keep it symmetrical. This makes the stack mechanically stable and prevents it from warping. Also the power and ground plane of each power system can be placed closer together, thus increasing the high-frequency bypass capacitance significantly.

Refer to the [Digital Isolator Design Guide](#) for detailed layout recommendations.

11.1.1 PCB Material

For digital circuit boards operating at less than 150 Mbps, (or rise and fall times greater than 1 ns), and trace lengths of up to 10 inches, use standard FR-4 UL94V-0 printed circuit board. This PCB is preferred over cheaper alternatives because of lower dielectric losses at high frequencies, less moisture absorption, greater strength and stiffness, and the self-extinguishing flammability-characteristics.

11.2 Layout Example

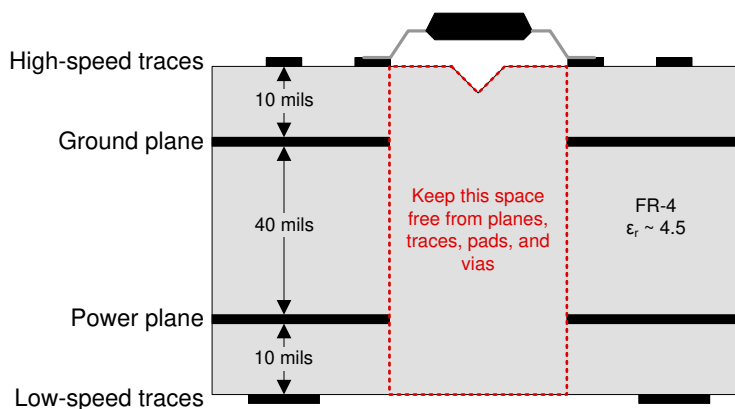

Figure 34. Recommended Layer Stack

Layout Example (continued)

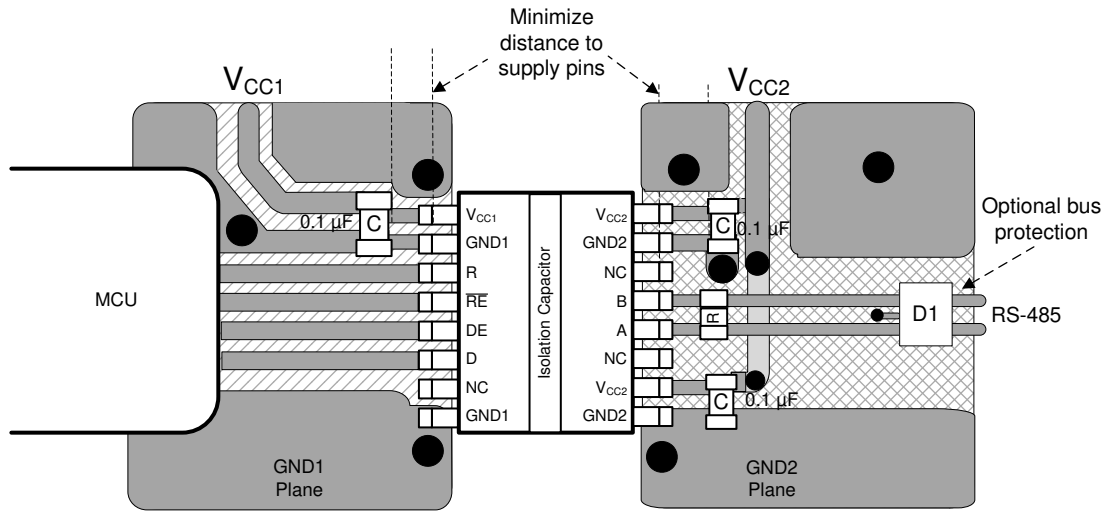

Figure 35. Layout Example

12 Device and Documentation Support

12.1 Documentation Support

12.1.1 Related Documentation

For related documentation see the following:

- Texas Instruments, [Digital Isolator Design Guide](#)
- Texas Instruments, [Isolation Glossary](#)
- Texas Instruments, [ISO1500 Isolated RS-485 Half-Duplex Evaluation Module use's guide](#)

12.2 Receiving Notification of Documentation Updates

To receive notification of documentation updates, navigate to the device product folder on ti.com. In the upper right corner, click on *Alert me* to register and receive a weekly digest of any product information that has changed. For change details, review the revision history included in any revised document.

12.3 Community Resource

TI E2E™ [support forums](#) are an engineer's go-to source for fast, verified answers and design help — straight from the experts. Search existing answers or ask your own question to get the quick design help you need.

Linked content is provided "AS IS" by the respective contributors. They do not constitute TI specifications and do not necessarily reflect TI's views; see TI's [Terms of Use](#).

12.4 Trademarks

E2E is a trademark of Texas Instruments.

All other trademarks are the property of their respective owners.

12.5 Electrostatic Discharge Caution



This integrated circuit can be damaged by ESD. Texas Instruments recommends that all integrated circuits be handled with appropriate precautions. Failure to observe proper handling and installation procedures can cause damage.

ESD damage can range from subtle performance degradation to complete device failure. Precision integrated circuits may be more susceptible to damage because very small parametric changes could cause the device not to meet its published specifications.

12.6 Glossary

[SLYZ022](#) — *TI Glossary*.

This glossary lists and explains terms, acronyms, and definitions.

13 Mechanical, Packaging, and Orderable Information

The following pages include mechanical packaging and orderable information. This information is the most current data available for the designated devices. This data is subject to change without notice and revision of this document. For browser-based versions of this data sheet, refer to the left-hand navigation.

PACKAGING INFORMATION

Orderable Device	Status (1)	Package Type	Package Drawing	Pins	Package Qty	Eco Plan (2)	Lead finish/ Ball material (6)	MSL Peak Temp (3)	Op Temp (°C)	Device Marking (4/5)	Samples
ISO1500DBQ	ACTIVE	SSOP	DBQ	16	75	RoHS & Green	NIPDAU	Level-2-260C-1 YEAR	-40 to 125	1500	Samples
ISO1500DBQR	ACTIVE	SSOP	DBQ	16	2500	RoHS & Green	NIPDAU	Level-2-260C-1 YEAR	-40 to 125	1500	Samples

(1) The marketing status values are defined as follows:

ACTIVE: Product device recommended for new designs.

LIFEBUY: TI has announced that the device will be discontinued, and a lifetime-buy period is in effect.

NRND: Not recommended for new designs. Device is in production to support existing customers, but TI does not recommend using this part in a new design.

PREVIEW: Device has been announced but is not in production. Samples may or may not be available.

OBSELETE: TI has discontinued the production of the device.

(2) **RoHS:** TI defines "RoHS" to mean semiconductor products that are compliant with the current EU RoHS requirements for all 10 RoHS substances, including the requirement that RoHS substance do not exceed 0.1% by weight in homogeneous materials. Where designed to be soldered at high temperatures, "RoHS" products are suitable for use in specified lead-free processes. TI may reference these types of products as "Pb-Free".

RoHS Exempt: TI defines "RoHS Exempt" to mean products that contain lead but are compliant with EU RoHS pursuant to a specific EU RoHS exemption.

Green: TI defines "Green" to mean the content of Chlorine (Cl) and Bromine (Br) based flame retardants meet JS709B low halogen requirements of <=1000ppm threshold. Antimony trioxide based flame retardants must also meet the <=1000ppm threshold requirement.

(3) MSL, Peak Temp. - The Moisture Sensitivity Level rating according to the JEDEC industry standard classifications, and peak solder temperature.

(4) There may be additional marking, which relates to the logo, the lot trace code information, or the environmental category on the device.

(5) Multiple Device Markings will be inside parentheses. Only one Device Marking contained in parentheses and separated by a "~" will appear on a device. If a line is indented then it is a continuation of the previous line and the two combined represent the entire Device Marking for that device.

(6) Lead finish/Ball material - Orderable Devices may have multiple material finish options. Finish options are separated by a vertical ruled line. Lead finish/Ball material values may wrap to two lines if the finish value exceeds the maximum column width.

Important Information and Disclaimer:The information provided on this page represents TI's knowledge and belief as of the date that it is provided. TI bases its knowledge and belief on information provided by third parties, and makes no representation or warranty as to the accuracy of such information. Efforts are underway to better integrate information from third parties. TI has taken and continues to take reasonable steps to provide representative and accurate information but may not have conducted destructive testing or chemical analysis on incoming materials and chemicals. TI and TI suppliers consider certain information to be proprietary, and thus CAS numbers and other limited information may not be available for release.

In no event shall TI's liability arising out of such information exceed the total purchase price of the TI part(s) at issue in this document sold by TI to Customer on an annual basis.

TAPE AND REEL INFORMATION

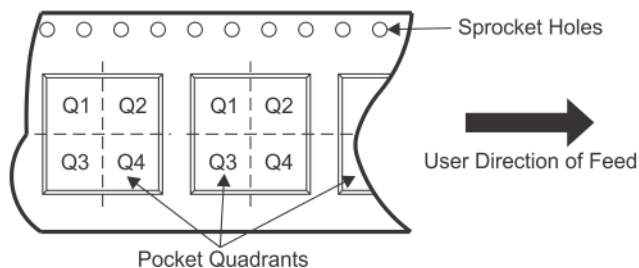
QUADRANT ASSIGNMENTS FOR PIN 1 ORIENTATION IN TAPE

*All dimensions are nominal

Device	Package Type	Package Drawing	Pins	SPQ	Reel Diameter (mm)	Reel Width W1 (mm)	A0 (mm)	B0 (mm)	K0 (mm)	P1 (mm)	W (mm)	Pin1 Quadrant
ISO1500DBQR	SSOP	DBQ	16	2500	330.0	12.4	6.4	5.2	2.1	8.0	12.0	Q1

TAPE AND REEL BOX DIMENSIONS

*All dimensions are nominal

Device	Package Type	Package Drawing	Pins	SPQ	Length (mm)	Width (mm)	Height (mm)
ISO1500DBQR	SSOP	DBQ	16	2500	350.0	350.0	43.0

TUBE

*All dimensions are nominal

Device	Package Name	Package Type	Pins	SPQ	L (mm)	W (mm)	T (μm)	B (mm)
ISO1500DBQ	DBQ	SSOP	16	75	505.46	6.76	3810	4



DBQ0016A

PACKAGE OUTLINE

SSOP - 1.75 mm max height

SHRINK SMALL-OUTLINE PACKAGE

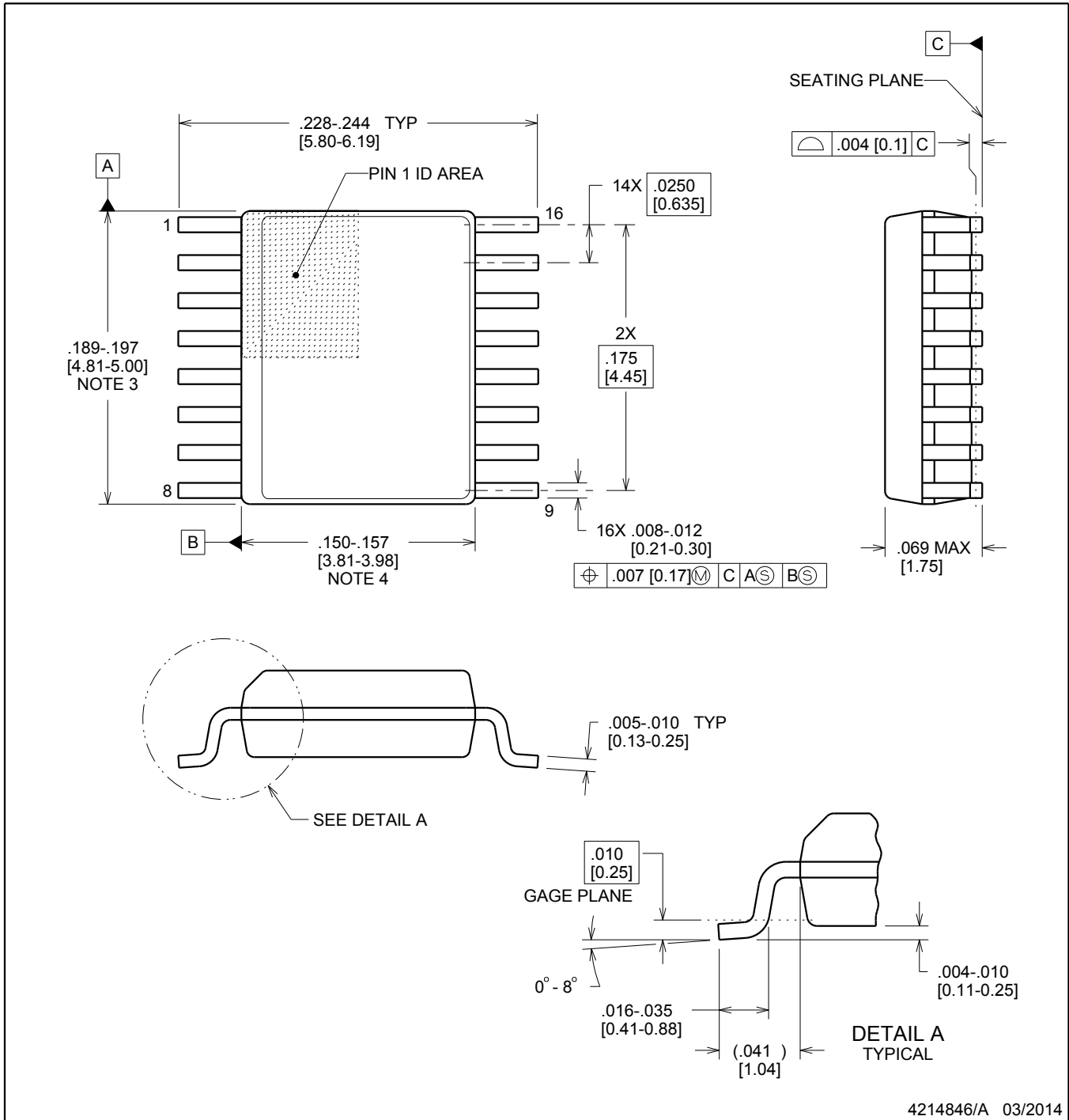

4214846/A 03/2014

NOTES:

1. Linear dimensions are in inches [millimeters]. Dimensions in parenthesis are for reference only. Controlling dimensions are in inches. Dimensioning and tolerancing per ASME Y14.5M.
2. This drawing is subject to change without notice.
3. This dimension does not include mold flash, protrusions, or gate burrs. Mold flash, protrusions, or gate burrs shall not exceed .006 inch, per side.
4. This dimension does not include interlead flash.
5. Reference JEDEC registration MO-137, variation AB.

EXAMPLE BOARD LAYOUT

DBQ0016A

SSOP - 1.75 mm max height

SHRINK SMALL-OUTLINE PACKAGE

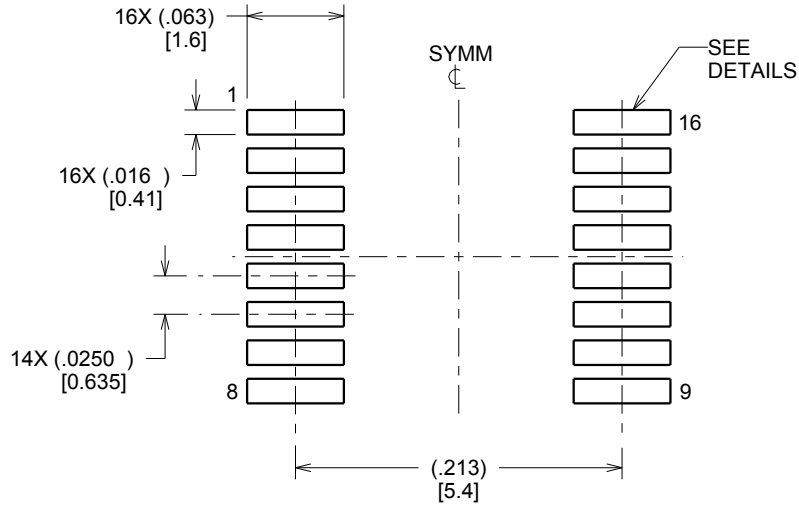

LAND PATTERN EXAMPLE
SCALE:8X

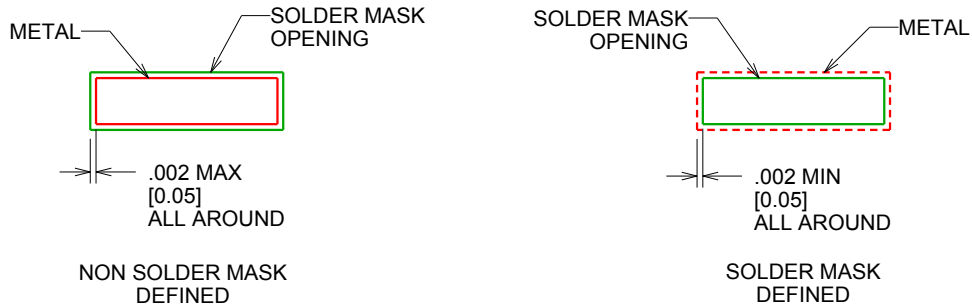

SOLDER MASK DETAILS

4214846/A 03/2014

NOTES: (continued)

6. Publication IPC-7351 may have alternate designs.

7. Solder mask tolerances between and around signal pads can vary based on board fabrication site.

EXAMPLE STENCIL DESIGN

DBQ0016A

SSOP - 1.75 mm max height

SHRINK SMALL-OUTLINE PACKAGE

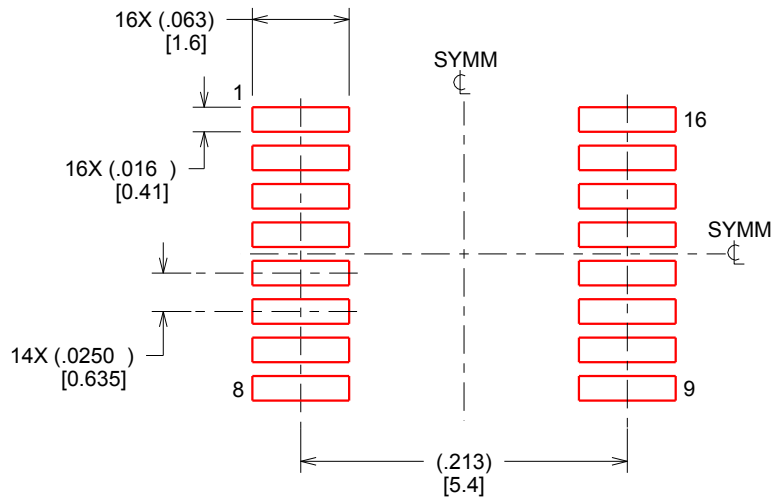

SOLDER PASTE EXAMPLE
BASED ON .005 INCH [0.127 MM] THICK STENCIL
SCALE:8X

4214846/A 03/2014

NOTES: (continued)

8. Laser cutting apertures with trapezoidal walls and rounded corners may offer better paste release. IPC-7525 may have alternate design recommendations.
9. Board assembly site may have different recommendations for stencil design.

IMPORTANT NOTICE AND DISCLAIMER

TI PROVIDES TECHNICAL AND RELIABILITY DATA (INCLUDING DATA SHEETS), DESIGN RESOURCES (INCLUDING REFERENCE DESIGNS), APPLICATION OR OTHER DESIGN ADVICE, WEB TOOLS, SAFETY INFORMATION, AND OTHER RESOURCES "AS IS" AND WITH ALL FAULTS, AND DISCLAIMS ALL WARRANTIES, EXPRESS AND IMPLIED, INCLUDING WITHOUT LIMITATION ANY IMPLIED WARRANTIES OF MERCHANTABILITY, FITNESS FOR A PARTICULAR PURPOSE OR NON-INFRINGEMENT OF THIRD PARTY INTELLECTUAL PROPERTY RIGHTS.

These resources are intended for skilled developers designing with TI products. You are solely responsible for (1) selecting the appropriate TI products for your application, (2) designing, validating and testing your application, and (3) ensuring your application meets applicable standards, and any other safety, security, regulatory or other requirements.

These resources are subject to change without notice. TI grants you permission to use these resources only for development of an application that uses the TI products described in the resource. Other reproduction and display of these resources is prohibited. No license is granted to any other TI intellectual property right or to any third party intellectual property right. TI disclaims responsibility for, and you will fully indemnify TI and its representatives against, any claims, damages, costs, losses, and liabilities arising out of your use of these resources.

TI's products are provided subject to [TI's Terms of Sale](#) or other applicable terms available either on [ti.com](#) or provided in conjunction with such TI products. TI's provision of these resources does not expand or otherwise alter TI's applicable warranties or warranty disclaimers for TI products.

TI objects to and rejects any additional or different terms you may have proposed.

Mailing Address: Texas Instruments, Post Office Box 655303, Dallas, Texas 75265
Copyright © 2022, Texas Instruments Incorporated