

QTY. OF CIRC. "XX"	DIM. "A"	DIM. "B"	DIM. "C"	ASSEMBLY MATERIAL # (STANDARD)	ASSEMBLY MATERIAL # (-58 OPTION)
02	63.6 [2.50]	17.46 [.688]	52.39 [2.063]	38280-0102	38280-0402
03	81.0 [3.19]	34.93 [1.375]	69.85 [2.750]	38280-0103	38280-0403
04	98.5 [3.88]	52.39 [2.063]	87.31 [3.438]	38280-0104	38280-0404
05	116.0 [4.57]	69.85 [2.750]	104.78 [4.125]	38280-0105	38280-0405
06	133.4 [5.25]	87.31 [3.438]	122.24 [4.813]	38280-0106	38280-0406
07	150.9 [5.94]	104.78 [4.125]	139.70 [5.500]	38280-0107	38280-0407
08	168.3 [6.63]	122.24 [4.813]	157.16 [6.188]	38280-0108	38280-0408
09	185.8 [7.32]	139.70 [5.500]	174.63 [6.875]	38280-0109	38280-0409
10	203.3 [8.00]	157.16 [6.188]	192.09 [7.563]	38280-0110	38280-0410
11	220.7 [8.69]	174.63 [6.875]	209.55 [8.250]	38280-0111	38280-0411
12	238.2 [9.38]	192.09 [7.563]	227.01 [8.938]	38280-0112	38280-0412

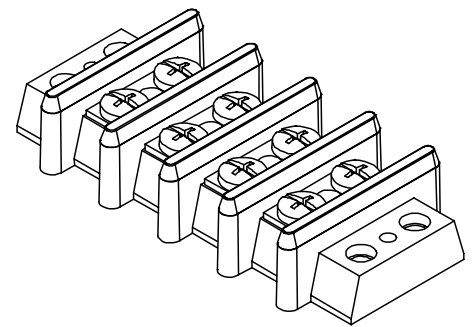

4 CIRCUIT SHOWN

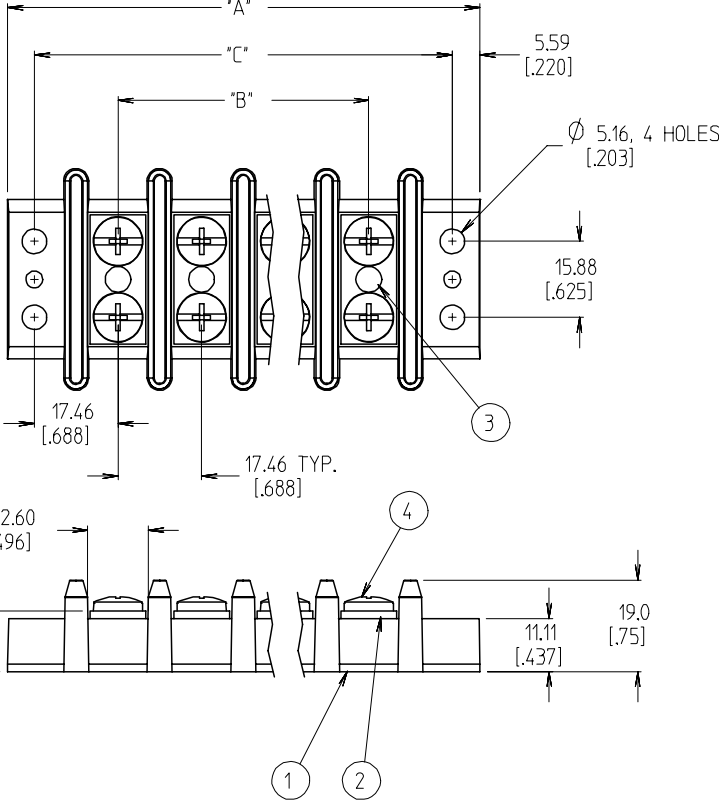
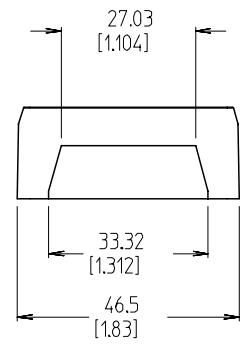

- NOTES:
1. MATERIAL: SEE TABLE
 2. FINISHES: SEE TABLE
 3. PRODUCT SPECIFICATION: NOT REQUIRED
 4. PACKAGING: NOT REQUIRED
 5. MATES WITH: NONE
 6. "XX" REFERS TO THE QUANTITY OF CIRCUITS.
 7. -58 OPTION: DO NOT SUPPLY SCREWS.
 8. INCH DIMENSIONS ARE SHOWN IN BRACKETS [LXXX].
 9. ALL COMPONENTS ARE ROHS COMPLIANT.

ITEM	QTY	DESCRIPTION	MATERIAL	FINISH
4	XX*2	SCREW, #10-32, DOG PNT, PHIL-SLOT	BRASS	NICKEL
3	XX	RIVET, SEMI-TUBE	BRASS	ZN, CLEAR CHROMATE
2	XX	TERMINAL, EYELET, TWIN	BRASS	BRIGHT NICKEL
1	1	INSULATOR, DR, AS MOLDED	PHENOLIC	BLACK

ADDED -58 OPTION
 EC NO: ETC2006-0510
 2006/06/22
 DRW:NEHLE
 2006/07/13
 CHK:DRROSS
 2006/07/13
 APPR:JMACNEIL

QUALITY SYMBOLS
 ▽=0
 ▽=0

DESCRIPTION
 REV

GENERAL TOLERANCES (UNLESS SPECIFIED)	
mm	INCH
4 PLACES ± ---	±.0015
3 PLACES ± 0.038	±.005
2 PLACES ± 0.13	±.01
1 PLACE ± 0.3	± ---
ANGULAR ± 2 °	

DRAFT WHERE APPLICABLE
 MUST REMAIN WITHIN DIMENSIONS

DIMENSION STYLE	
MM/IN	SCALE
1:1 <td>DESIGN UNITS INCH</td>	DESIGN UNITS INCH
DRAWN BY R. KEMP	DATE 2003/05/09
CHECKED BY R. STONE	DATE 2003/05/12
APPROVED BY P. WALTZ	DATE 2003/05/13
MATERIAL NO. SEE CHART	DOCUMENT NO. SD-38280-001

THIRD ANGLE PROJECTION

17.46MM [.688] DR BTS, PHENOLIC ASSY

MOLEX INCORPORATED

SHEET NO. 1 OF 1

THIS DRAWING CONTAINS INFORMATION THAT IS PROPRIETARY TO MOLEX INCORPORATED AND SHOULD NOT BE USED WITHOUT WRITTEN PERMISSION