

DO NOT SCALE FROM THIS PRINT

TABLE 1 - SOLDERBALL PARTS ONLY				
PART (POSITION)	20	30	40	50
MAX COPLANARITY	.0040 [0.102]	.0080 [0.203]	.0080 [0.203]	.0100 [0.254]
MAX T/B BOW *	.0020 [0.051]	.0020 [0.051]	.0020 [0.051]	.0025 [0.064]

\* AFTER SOLDERBALL ATTACHMENT

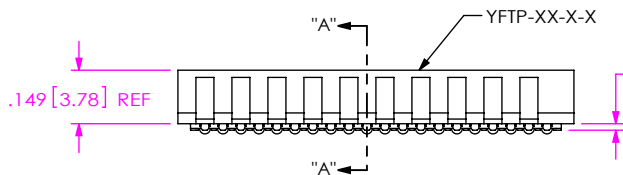
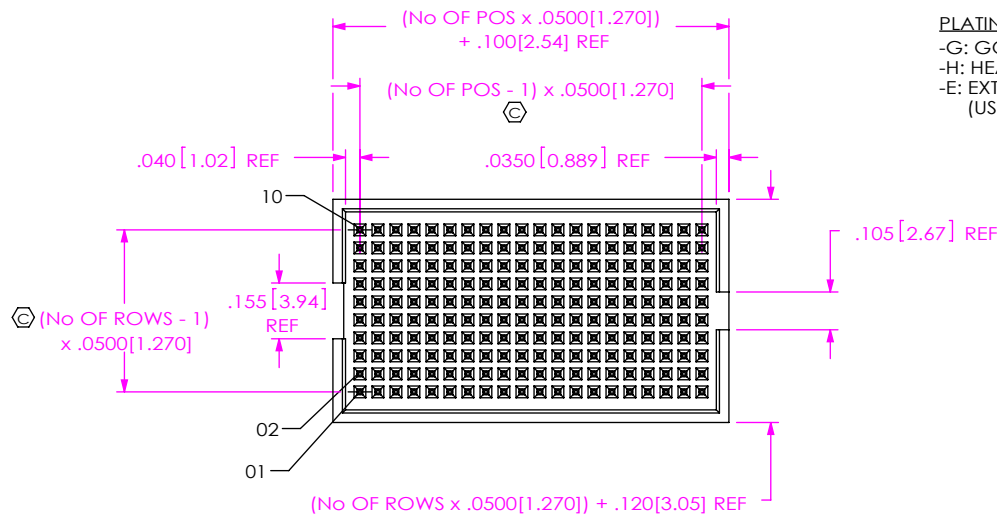

NOTES:

- NOTE DELETED.
- ⊗ REPRESENTS A CRITICAL DIMENSION.
- BURR ALLOWANCE: .0015 MAX.
- NOTE DELETED.
- MINIMUM PUSHOUT FORCE: .5 LB.
- NOTE DELETED.
- MAXIMUM ALLOWABLE DISTANCE FOR SOLDER WICKING UP TERMINAL.
- ⊗ .0040 MAX VARIATION BETWEEN SOLDERBALLS.
- REFER TO VISUAL INSPECTION BOARD FOR SOLDERBALL APPEARANCE CHECKS.
- THE DISTANCE FROM THE CENTER OF ANY SOLDERBALL TO THE CENTER OF ANY ADJACENT INNER PEG SHALL BE .025 ± .005.
- NOTE DELETED.
- TRAY PACKAGING CAN BE SUBSTITUTED FOR TUBES.
- TUBES ARE STANDARD PACKAGING.
- ORDERS WILL BE PACKAGED ACCORDING TO THE SAMTEC PACKAGING EFFICIENCY STANDARDS (SPES) FOUND ON WWW.SAMTEC.COM.
- ATTACH LABEL TO EACH REEL.

YFT-XX-05-X-XX-SB-X-XX

No OF POSITIONS  
-20 THRU -50  
(MULTIPLES OF 10 ONLY)

LEAD STYLE

PLATING SPECIFICATION

- G: GOLD (USE T-1R24-05B-G-1)
- H: HEAVY GOLD (USE T-1R24-05B-H-1)
- E: EXTRA HEAVY GOLD (USE T-1R24-05B-E-1)

PACKAGING

- BLANK: TUBES (SEE NOTES 12 & 13)
- TR: TAPE & REEL (SEE NOTES 14 & 15)
- FR: FULL REEL QTY TAPE & REEL (SEE NOTES 14 & 15)

PICK & PLACE OPTION

- K: POLYAMIDE FILM (SEE TABLE 3 & FIG 2, SHT 2)

OPTION

- SB: SOLDER BALLS: 37% PB/63% SN (USE SDB-030-6337)

ROW SPECIFICATION

- 10: TEN ROWS (USE YFTP-XX-X)
- 08: EIGHT ROWS (USE YFTP-XX-X)
- 05: FIVE ROWS (USE YFTP-XX-X)
- 06: SIX ROWS (USE YFTP-XX-X) (AVAILABLE IN 20 POS. ONLY)
- 03: THREE ROWS (USE YFTP-XX-X) (AVAILABLE IN 20 POS. ONLY)

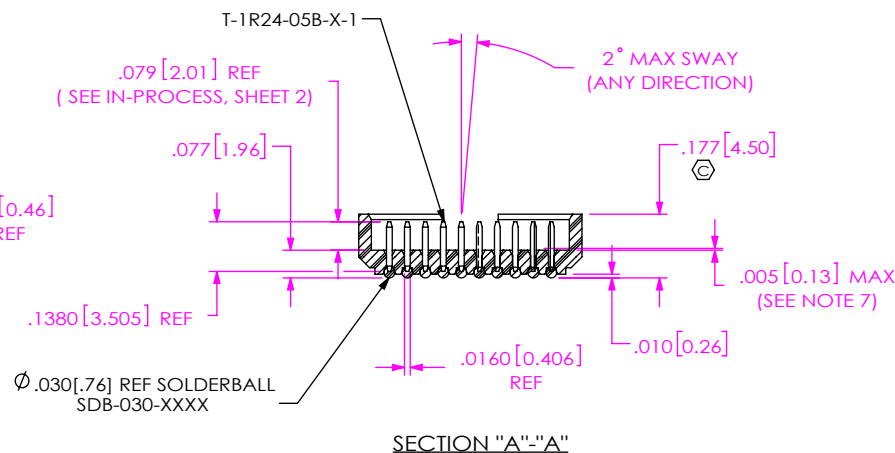
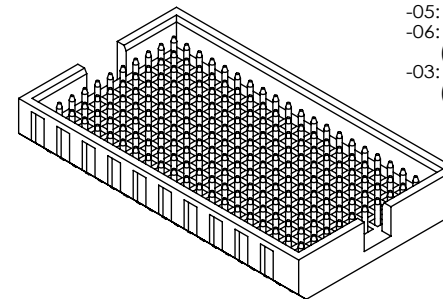

UNLESS OTHERWISE SPECIFIED, DIMENSIONS ARE IN INCHES. TOLERANCES ARE:

DECIMALS	ANGLES
.XX: ±.01	± 2°
.XXX: ±.005	
.XXXX: ±.0020	

PROPRIETARY NOTE  
THIS DOCUMENT CONTAINS CONFIDENTIAL AND PROPRIETARY INFORMATION AND ALL DESIGN, MANUFACTURING, REPRODUCTION, USE, PATENT RIGHTS AND SALES RIGHTS ARE EXPRESSLY RESERVED BY SAMTEC, INC. THIS DOCUMENT SHALL NOT BE DISCLOSED, IN WHOLE OR PART, TO ANY UNAUTHORIZED PERSON OR ENTITY NOR REPRODUCED, TRANSFERRED OR INCORPORATED IN ANY OTHER PROJECT IN ANY MANNER WITHOUT THE EXPRESS WRITTEN CONSENT OF SAMTEC, INC.



520 PARK EAST BLVD, NEW ALBANY, IN 47150  
PHONE: 812-944-6733 FAX: 812-948-5047  
e-Mail: info@SAMTEC.com code: 55322

MATERIAL: DO NOT SCALE DRAWING SHEET SCALE: 1.875:1  
INSULATOR: LCP, COLOR: BLACK  
TERMINAL: BRASS AND ALLOY 260

DESCRIPTION:  
Flex, Y, Z, .050 CENTERLINE TERMINAL ASSEMBLY

DWG. NO.  
YFT-XX-05-X-XX-SB-X-XX

BY: ERIC M 5/27/99 SHEET 1 OF 2

**FIG 2**  
 -K: KAPTON PAD OPTION  
 (YFT-120-05-X-08-K SHOWN)

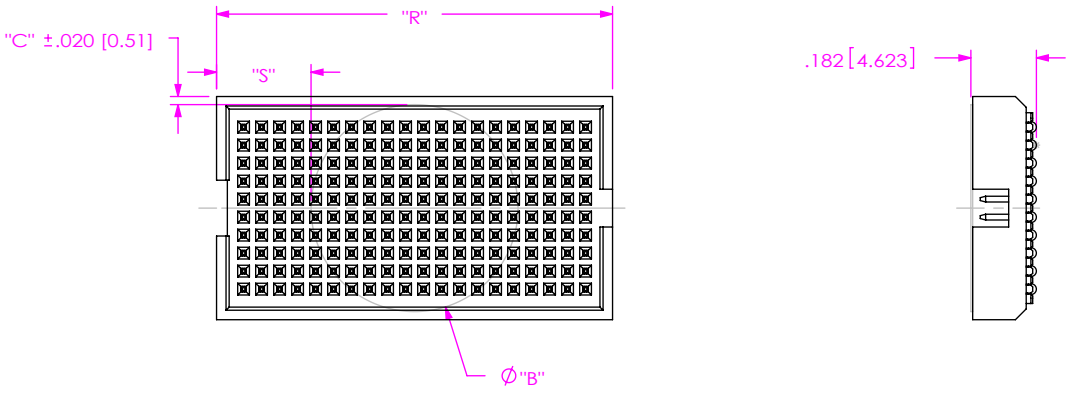

$R = (\text{No OF POS} \times .0500 [1.270]) + .100 [2.54]$   
 $S = ("R" - "B" / 2) \pm .020 [0.51]$

TABLE 3			
ROW OPTION	"B"	"C"	KAPTON
-05	.404 [10.25]	.017 [.43]	K-DOT-404-500-.005
-08	.575 [14.60]	.028 [.71]	K-850-650
-10	.650 [16.50]	.015 [.38]	K-1000-800
-06	.460 [11.68]	.020 [.51]	K-850-650
-03	.325 [8.26]	.028 [.71]	K-DOT-325-450-.005

IN-PROCESS WITHOUT SOLDERBALLS

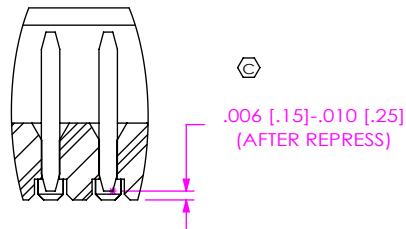
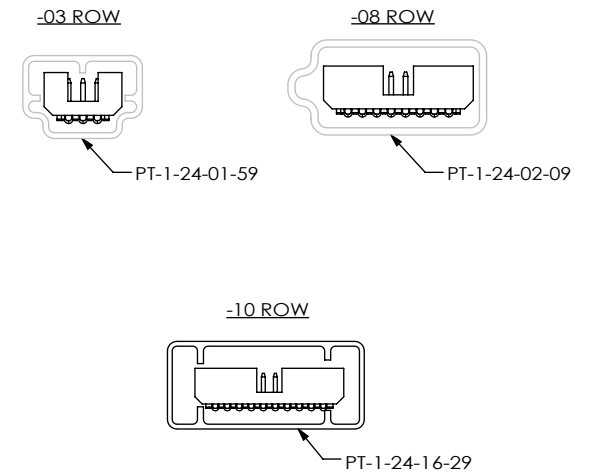

TABLE 2				
PART (POSITION)	20	30	40	50
MAX T/B BOW	.0015 [0.038]	.0020 [0.051]	.0020 [0.051]	.0020 [0.051]

PACKAGING TUBE  
 (SEE NOTE 12)

TABLE 4		
ROW OPTION	TUBE	PLUG
-03	PT-1-24-01-59	TP-24
-05	PT-1-24-01-61	TP-03
-06	PT-1-24-14-29	TP-07
-08	PT-1-24-02-09	TP-07
-10	PT-1-24-16-29	TP-07

[PLACE PARTS IN RESPECTIVE TUBES SIMILAR TO SHOWN BELOW]



**PROPRIETARY NOTE**

THIS DOCUMENT CONTAINS CONFIDENTIAL AND PROPRIETARY INFORMATION AND ALL DESIGN, MANUFACTURING, REPRODUCTION, USE, PATENT RIGHTS AND SALES RIGHTS ARE EXPRESSLY RESERVED BY SAMTEC, INC. THIS DOCUMENT SHALL NOT BE DISCLOSED, IN WHOLE OR PART, TO ANY UNAUTHORIZED PERSON OR ENTITY NOR REPRODUCED, TRANSFERRED OR INCORPORATED IN ANY OTHER PROJECT IN ANY MANNER WITHOUT THE EXPRESS WRITTEN CONSENT OF SAMTEC, INC.

DO NOT SCALE DRAWING

SHEET SCALE: 1.875:1



520 PARK EAST BLVD, NEW ALBANY, IN 47150  
 PHONE: 812-944-6733 FAX: 812-948-5047  
 e-Mail: info@SAMTEC.com code: 55322

DESCRIPTION:  
 FleX, Y, Z, .050 CENTERLINE TERMINAL ASSEMBLY

DWG. NO.  
**YFT-XX-05-X-XX-SB-X-XX**

BY: ERIC M 5/27/99 SHEET 2 OF 2