

PART NAME

PLASTIC INSTRUMENT CASE

PART No.

IP-6130 & IP-6131

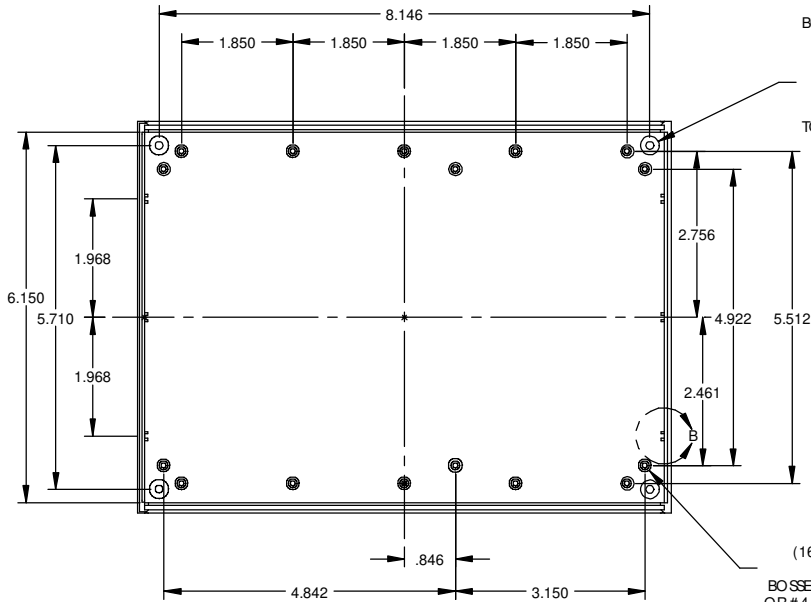

BOTTOM COVER:
 ϕ .248 ∇ .050
 92° C-SINK ∇ .665 (FROM INNER BOSS SURFACE)
 ϕ .132 THRU
 (FAR SIDE 4 PLCS)

TOP COVER:
 M3 BRASS INSERT (4 PLCS)

ϕ .218 BOSS
 ϕ .090 HOLE ∇ .218
 (16) PLCS BOTH COVERS

BOSS USE EITHER M 2.5 METRIC
 OR # 4 STD. SHEET METAL SCREWS
 (NOT SUPPLIED)

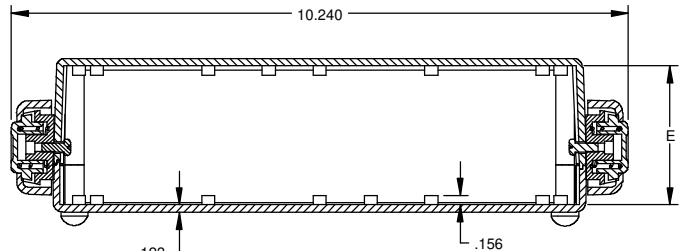
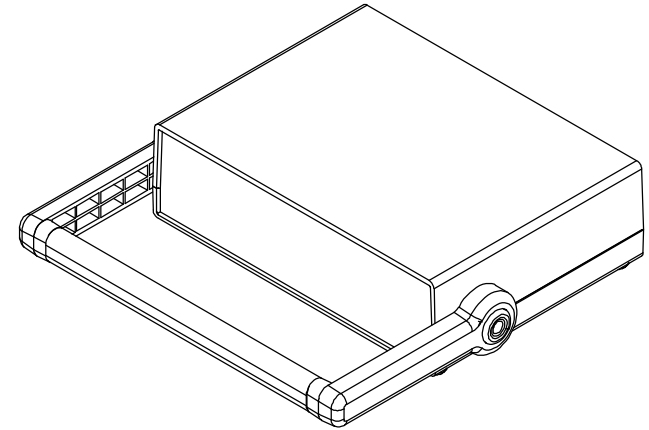

SECTION A-A

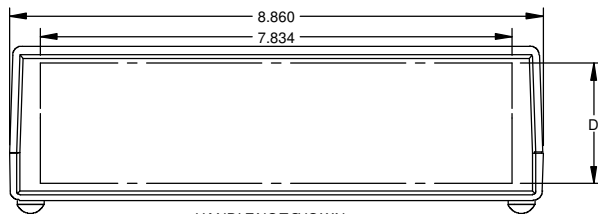

HANDLE NOT SHOWN

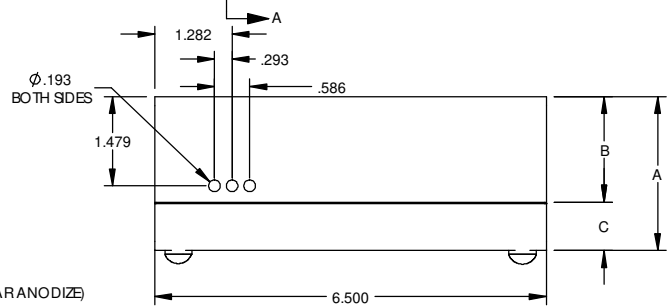
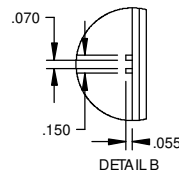
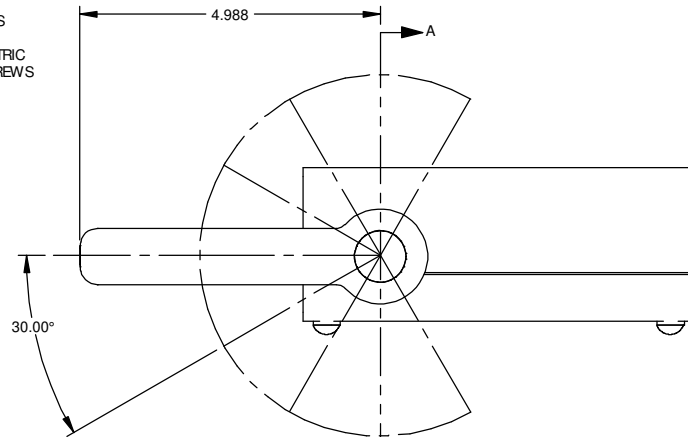

NOTES

- MATERIALS & FINISHES
- COVERS - ABS (LIGHT GREY)
- UL94-HB FLAMMABILITY RATING
- PANELS - ABS (BLACK)
- UL94-HB FLAMMABILITY RATING
- HANDLE SUPPORTS - ABS (GREY)
- UL94-HB FLAMMABILITY RATING
- HANDLE - ALUMINUM EXTRUSION (CLEAR ANODIZE)

HARDWARE INCLUDED:
 HANDLE KIT AND (2) M4 x 10mm PAN HEAD MOUNTING SCREWS INCLUDED
 (4) M3 x 25mm FLAT HEAD SCREWS
 (4) RUBBER FEET

ALL DIMENSIONS HAVE \pm .015 TOLERANCE UNLESS OTHERWISE SPECIFIED

PART No.	TOTAL HEIGHT	COVER HEIGHT	BASE HEIGHT	USABLE PANEL SPACE	INTERNAL CLEARANCE
	A	B	C	D	E
IP-6130	2.570	1.770	.800	2.012	2.324
IP-6131	3.540	1.770	1.770	2.982	3.294