

ENG. NO.

EDP NO.

SIMILAR ITEM

CADFILE NO.

DO NOT SCALE DRAWING

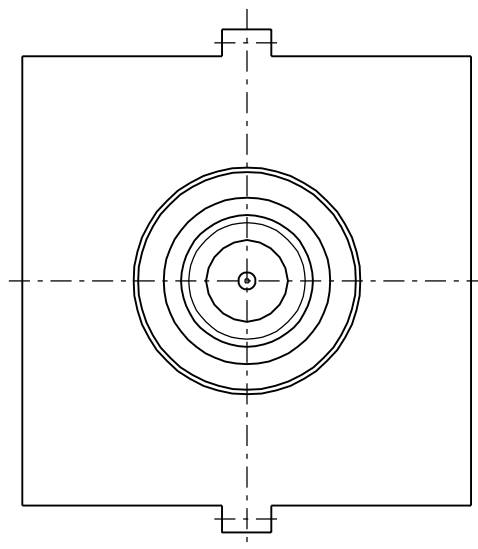

TYP.

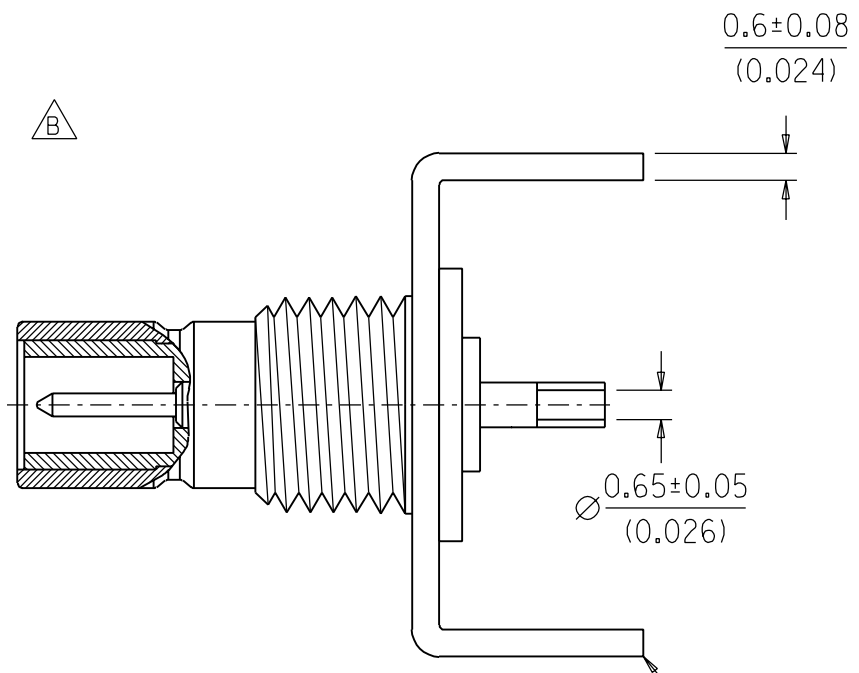

LEGS MAY NEED FORMING TO FIT PCB PATTERN

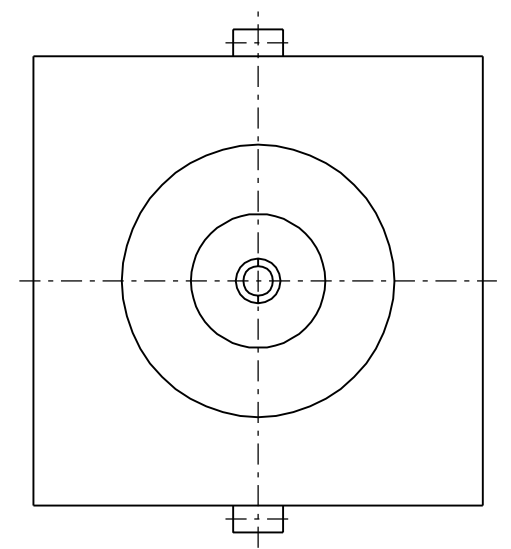

SMB JACK ASSEMBLY

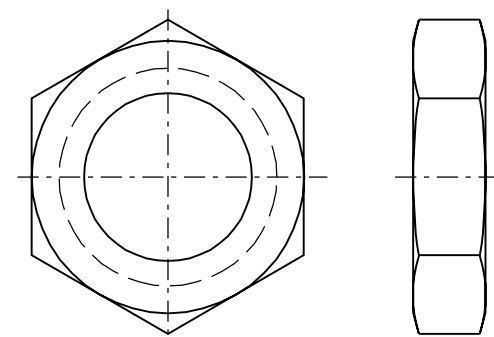

NUT

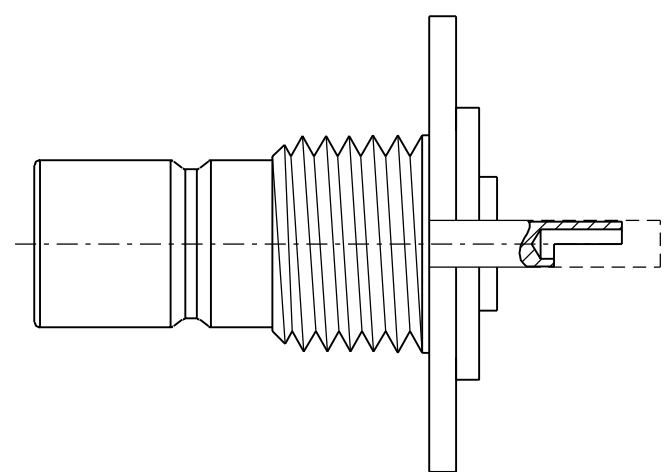

RECOMMENDED PANEL MOUNTING HOLE  
 PANEL THICKNESS: 1.775±0.025  
 MOUNTING TORQUE: 7-10 INCH/POUNDS

CONSTRUCTION :

- BODY -----BRASS
- DIELECTRIC -----TEFLON
- CONTACT -----BRASS
- FLANGE -----PHOSPHOR BRONZE
- NUT -----BRASS

FINISH:

- BODY -----GOLD PLATING
- CONTACT -----GOLD PLATING (GOLD FLASH)
- FLANGE -----TIN PLATING (200-400 μ")
- NUT -----GOLD PLATING

MECHANICAL AND ELECTRICAL CHARACTERISTICS:

PER PRODUCT SPECIFICATION: PS-73598-0099  
 (INSERTION LOSS IS NOT APPLICABLE)

PACKAGING :

TRAY

					MATERIAL : SEE NOTES		MOLEX TAIWAN LTD. (R.F. DIVISION)
					FINISH : SEE NOTES		
					SCALE : 6:1	UNIT : mm(INCH)	
					DRAWN BY : IRIS WANG 95/11/03		GENERAL TOLERANCES ANGLE : ± 3° DIM. ± 0.25 (±.01)
B	RELEASE TO MANUFACTURING	0934	IRIS	96/12/26	CHK'D BY :		DRW. NO.: SDA-73100-0208
AI	RELEASE TO TOOLING	0528	IRIS	95/10/13	APPR'D BY :		REV B
LTR	REVISION RECORD	ECN	DR	DATE			TITLE : 50 OHM SMB STRAIGHT JACK BULKHEAD (2-LEG) PCB RECEPTACLE
STANDARD ITEM					<input type="checkbox"/> YES <input checked="" type="checkbox"/> NO		SHEET   OF