

LOC	DIST	REVISIONS			
P	LTN	DESCRIPTION	DATE	DWN	APVD
E		REVISED PER ECR-21-10067	08APR2021	SS	VS
F		REVISED PER ECR-20-100915	28APR2021	JP	VS
G		REVISED PER ECR-22-130081	12OCT2022	SKR	DS
G1		REVISED PER ECR-22-141839	04NOV2022	RS	DS

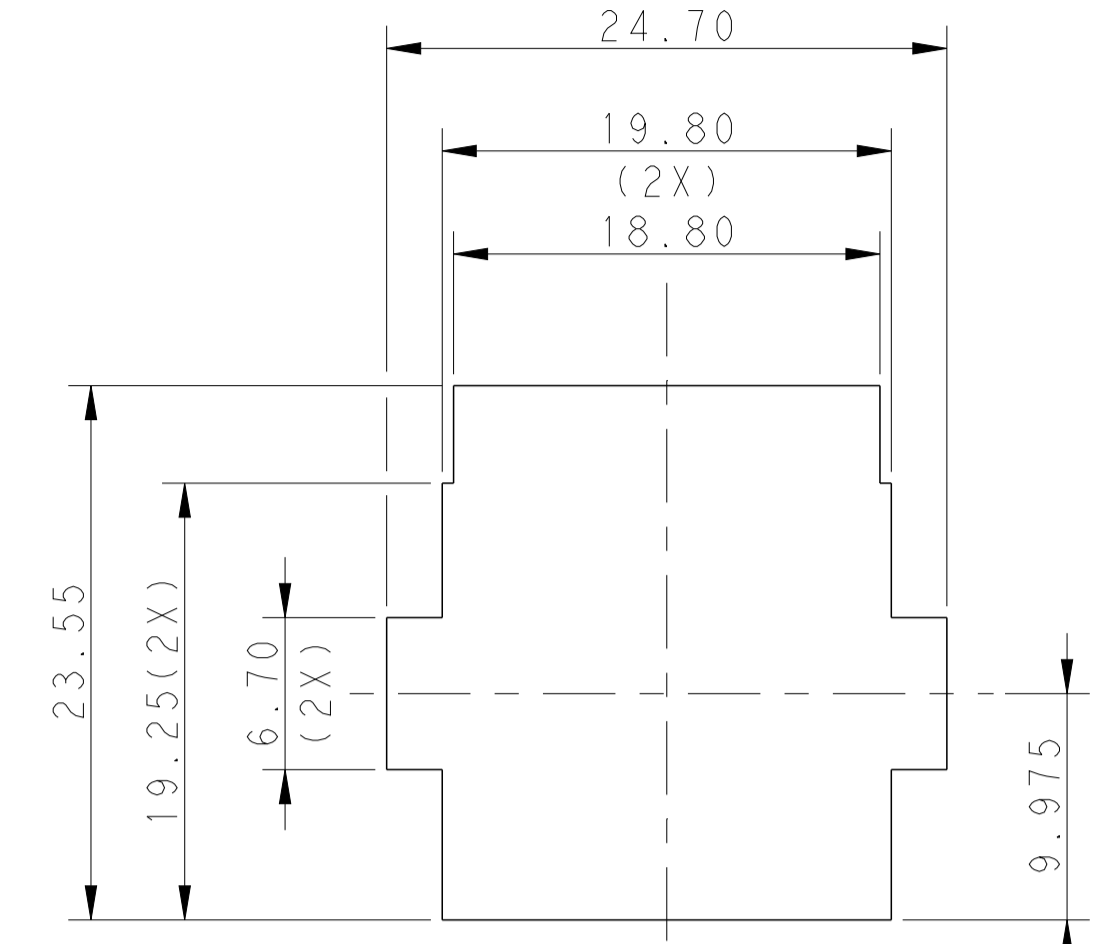

RECOMMENDED PANEL OPENING DIMENSIONS FOR CAP HOUSING 2\*6 AND 2\*5 AND 2\*4 POSITIONS (TOLERANCE: ±0.15mm)

RECOMMENDED PANEL OPENING DIMENSIONS FOR CAP HOUSING 2\*3 POSITION (TOLERANCE: ±0.15mm)

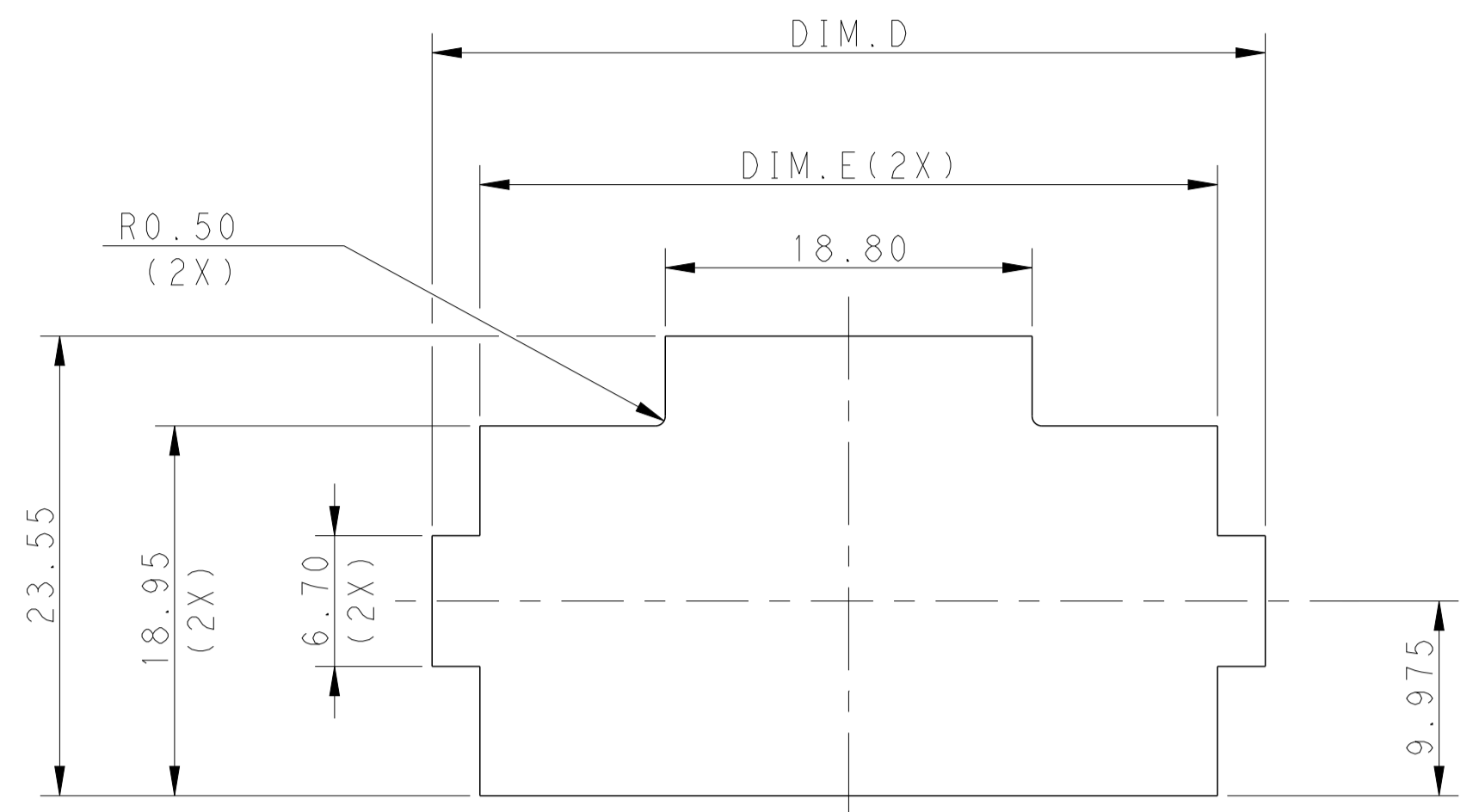
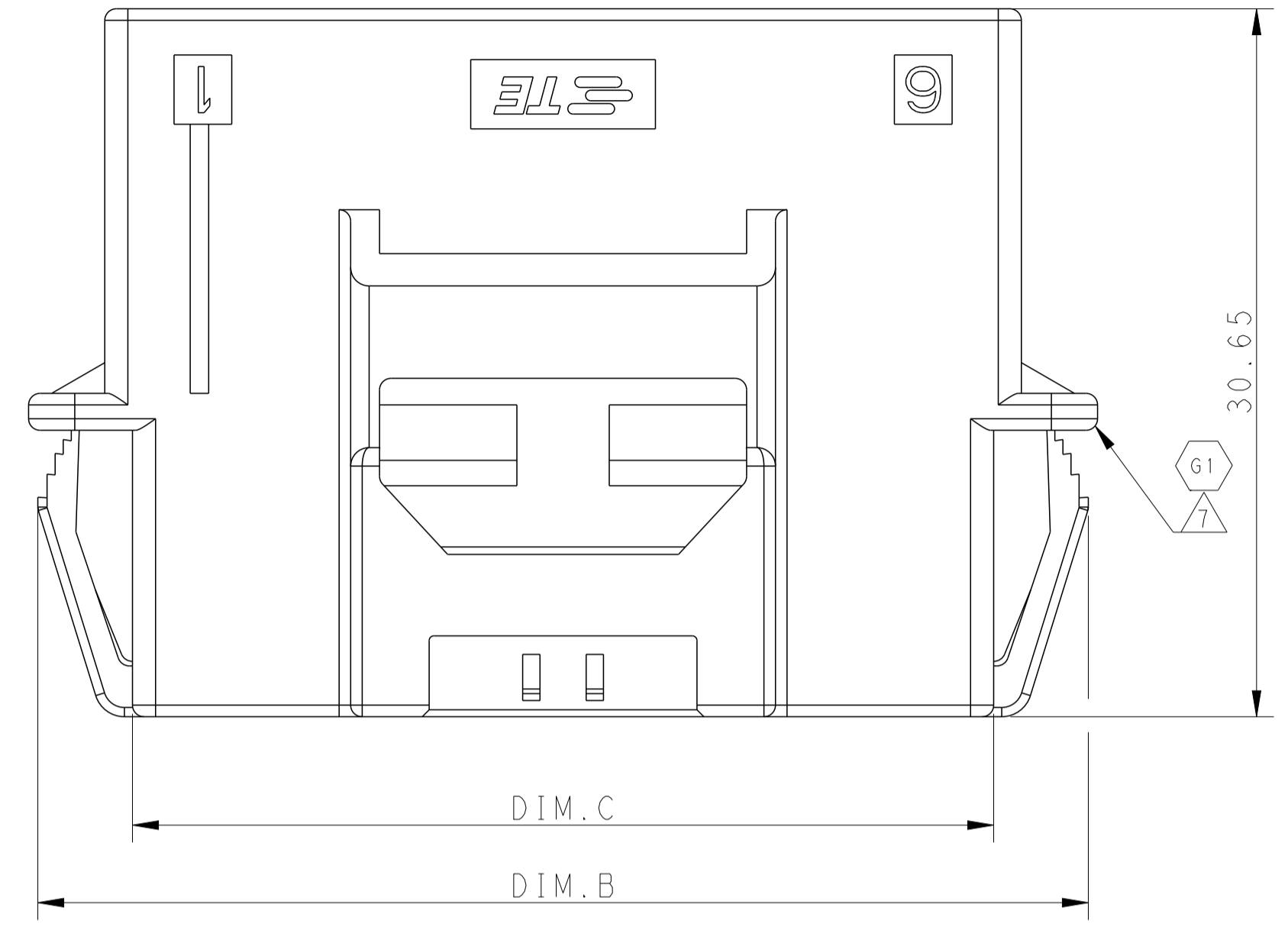
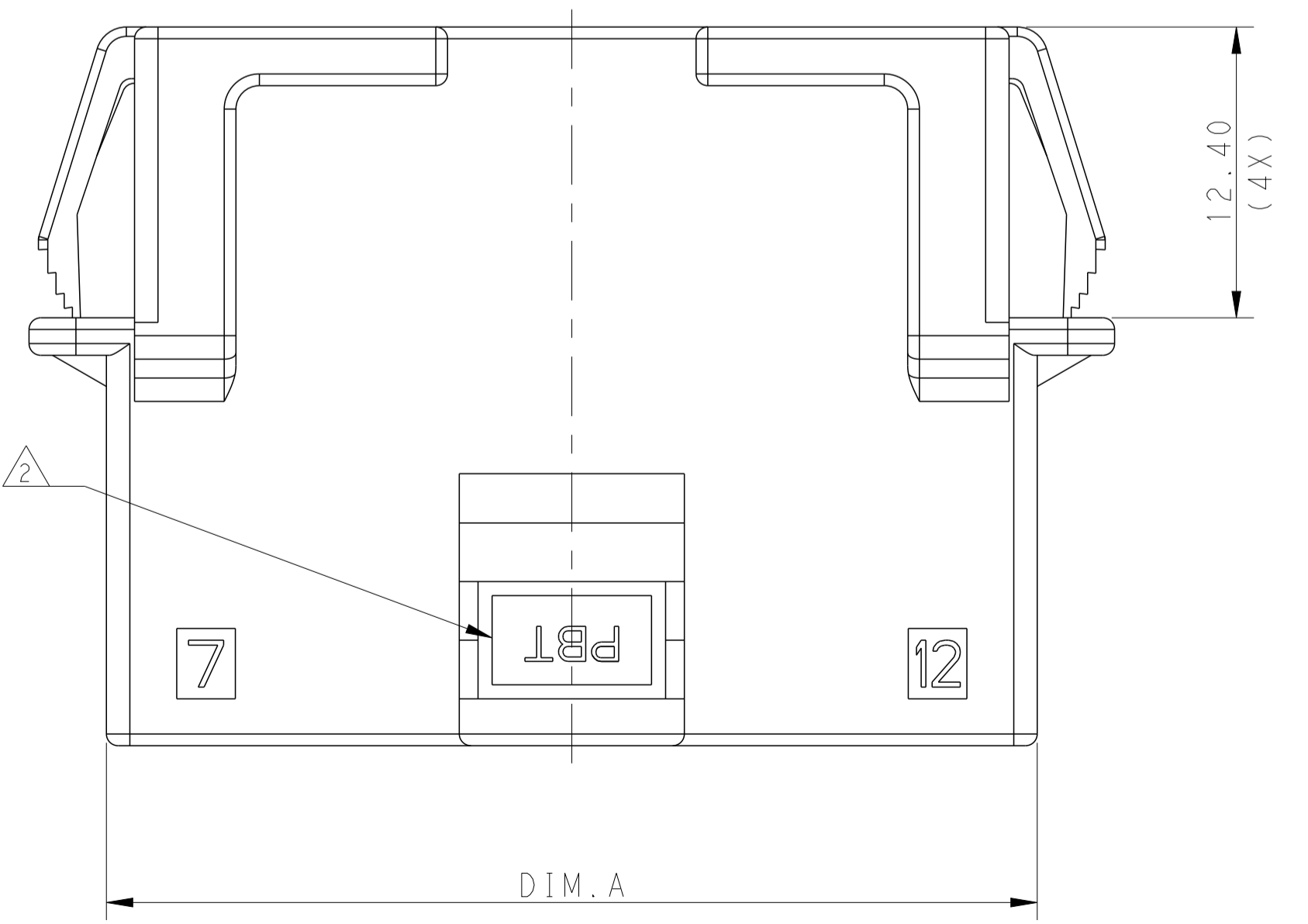
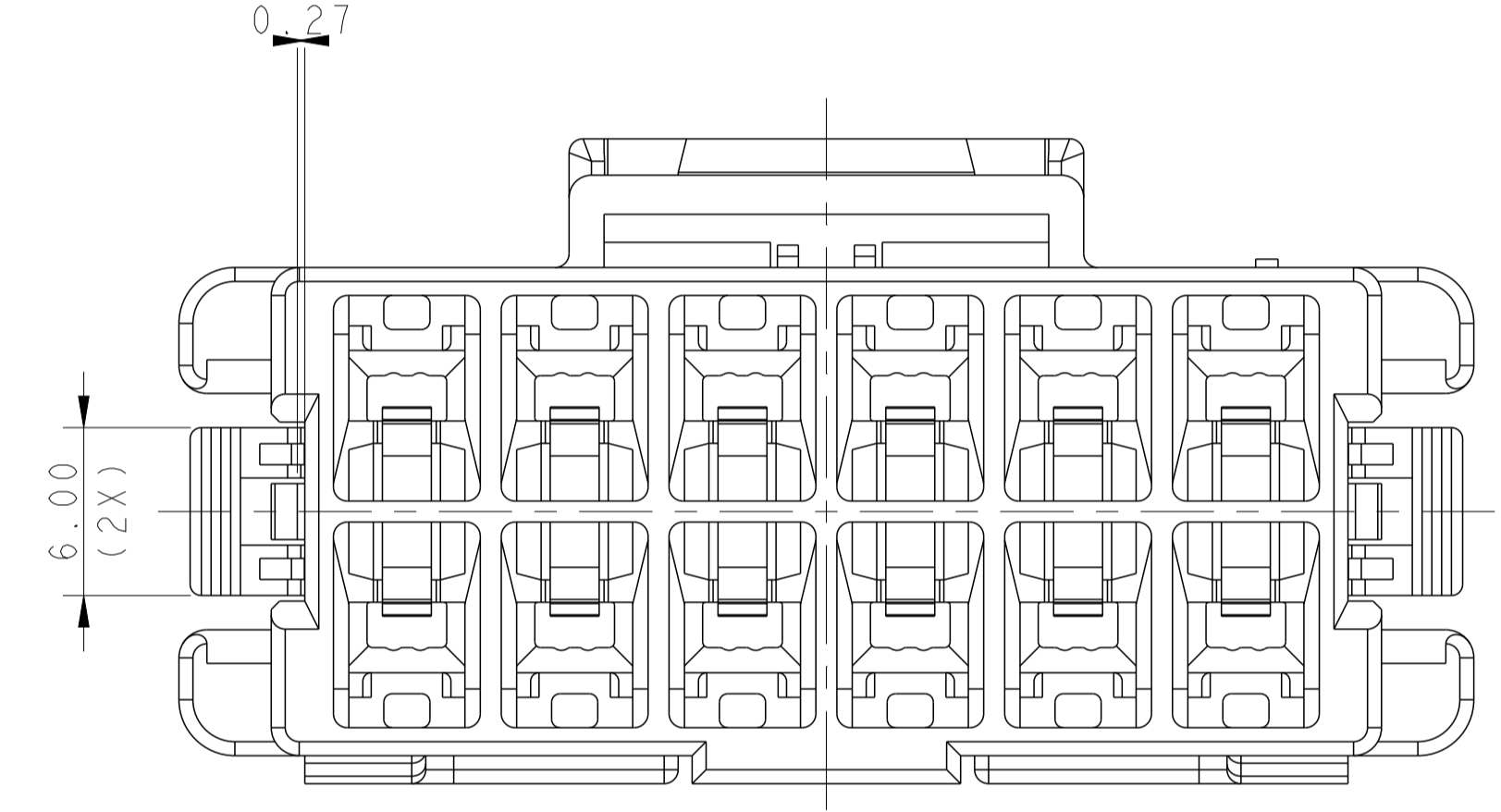
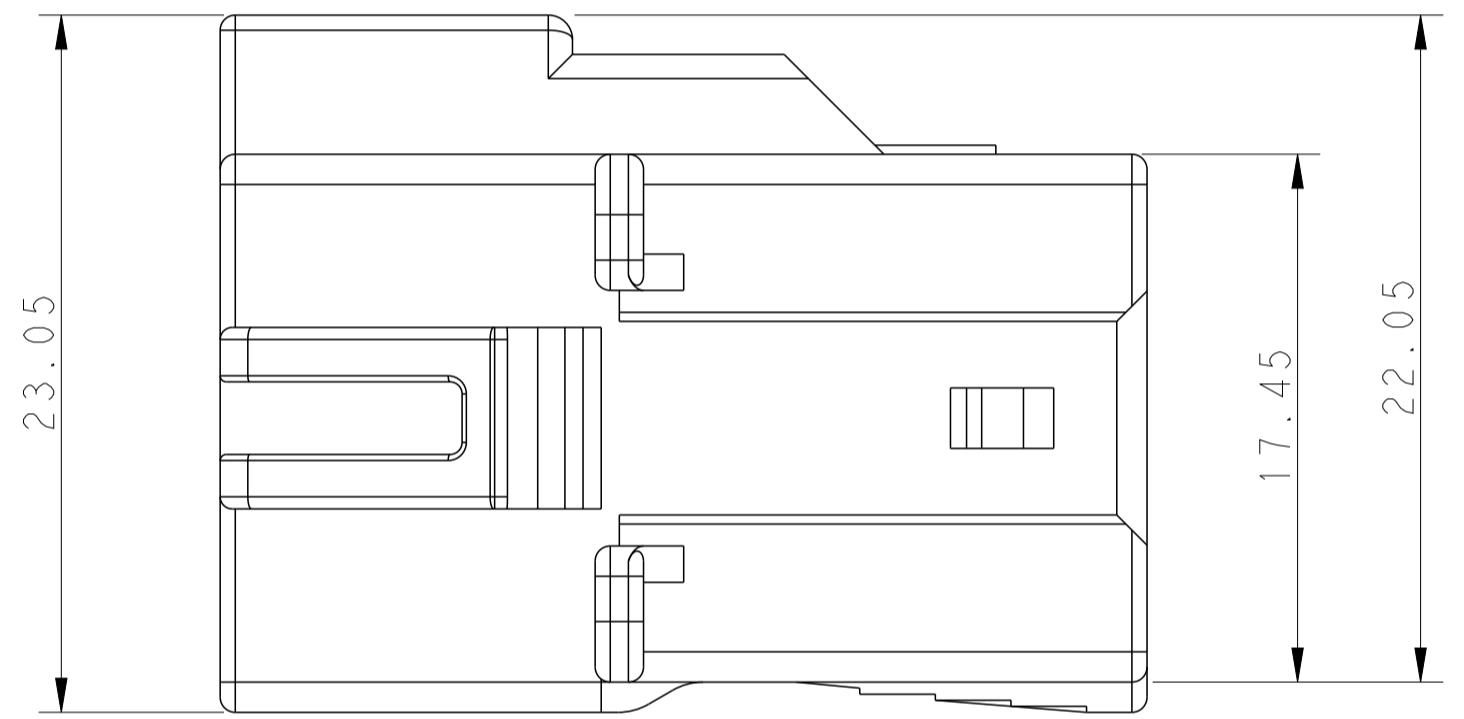
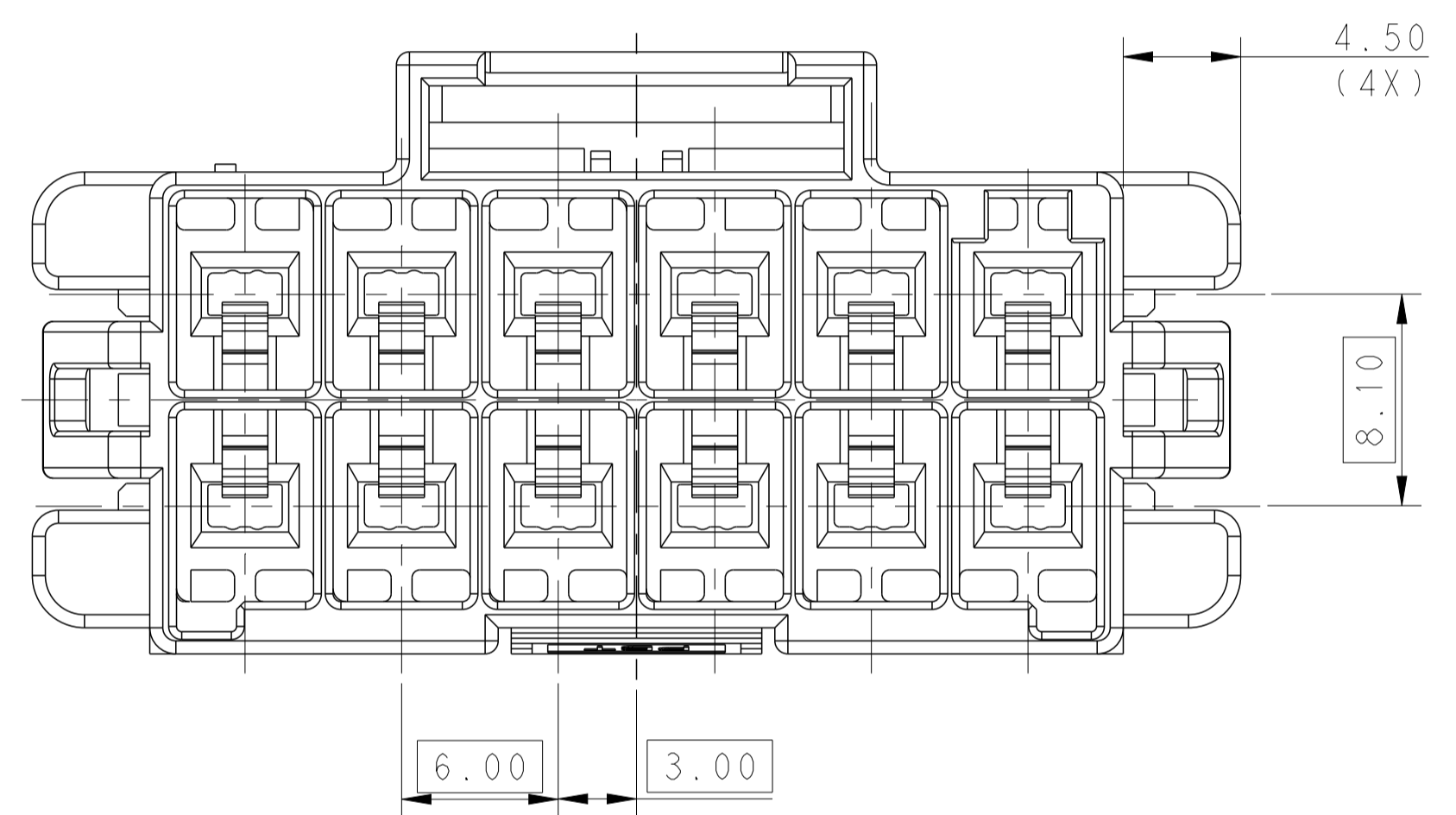

△ MATERIAL:  
 LEVEL 1: PBT, STANDARD TEMPERATURE 105°C  
 KEY A:NATURAL; KEY B:PURPLE; KEY C:BLUE; KEY D:YELLOW  
 LEVEL 2: PA66, HIGH TEMPERATURE 150°C  
 KEY A:LIGHT GREY; KEY B:RED; KEY C:BLACK; KEY D:NATURAL

△ MATERIAL MARK:  
 LEVEL 1:PBT, LEVEL 2:HDT

3. APPLICABLE CONTACT P/N  
 TAB CONTACT:1971238/1971780/82/84/86/88-\*,2238067-\*

4. MATING CONN, P/N  
 PLUG HSG: \*-1971776-  
 TPA(LOCK PLATE): \*-1971778-\*

5. RECOMMENDED PANEL THICKNESS:1.0-2.0mm

△ GLOW WIRE COMPLIANT IN ACCORDANCE WITH IEC 60335-1. THIS IS BASED ON THE PRODUCT MEETING A GWEPT 850°C TEST AND RESIN GWIT GREATER THAN OR EQUAL TO 775°C.

G1 △ RADIUS OPTIONAL, 4PLC

POS	A	B	C	D	E
2*6	39.70	45.5	37.30	42.70	37.80
2*5	33.70	39.5	31.30	36.70	31.80
2*4	27.70	33.5	25.30	30.70	25.80
2*3	21.70	27.5	19.30		

THIS DRAWING IS A CONTROLLED DOCUMENT.

DWN: TOMMY WU 06JUL2012  
 CHK: HAPYE WU 06JUL2012  
 APVD: YUHONG MAO 06JUL2012

NAME: CAP HOUSING, PANEL MOUNT, DOUBLE ROW POWER TRIPLE LOCK

PRODUCT SPEC: 108-106118  
 APPLICATION SPEC: 114-106118

SIZE: A1 00779  
 CAGE CODE: C=1971775  
 DRAWING NO: 108-106118

RESTRICTED TO: -

Customer Drawing SCALE: 4:1 SHEET 1 OF 2 REV: G1

LOC		DIST		REVISIONS			
P	LTN	DESCRIPTION	DATE	OWN	APVD		
-	-	SEE SHEET 1	-	-	-		

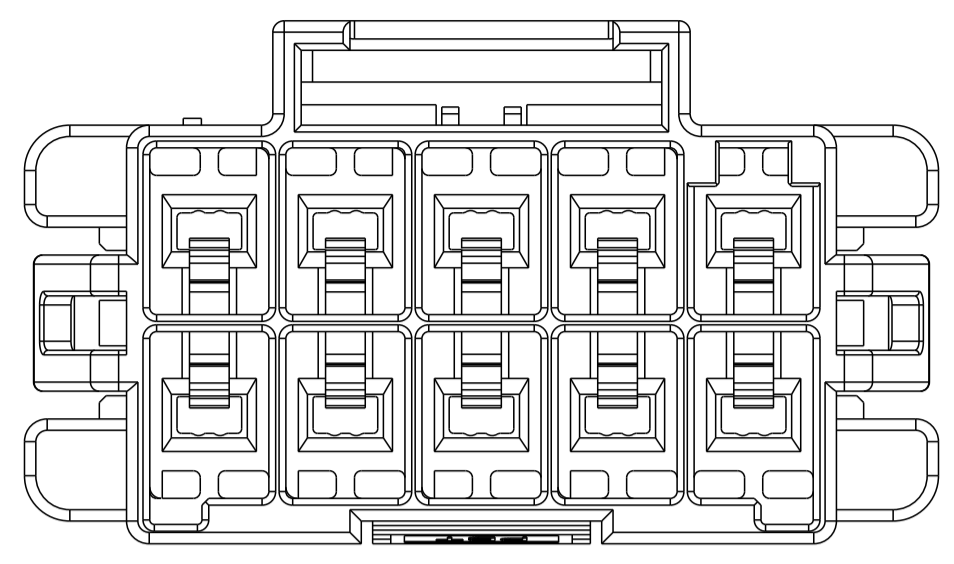
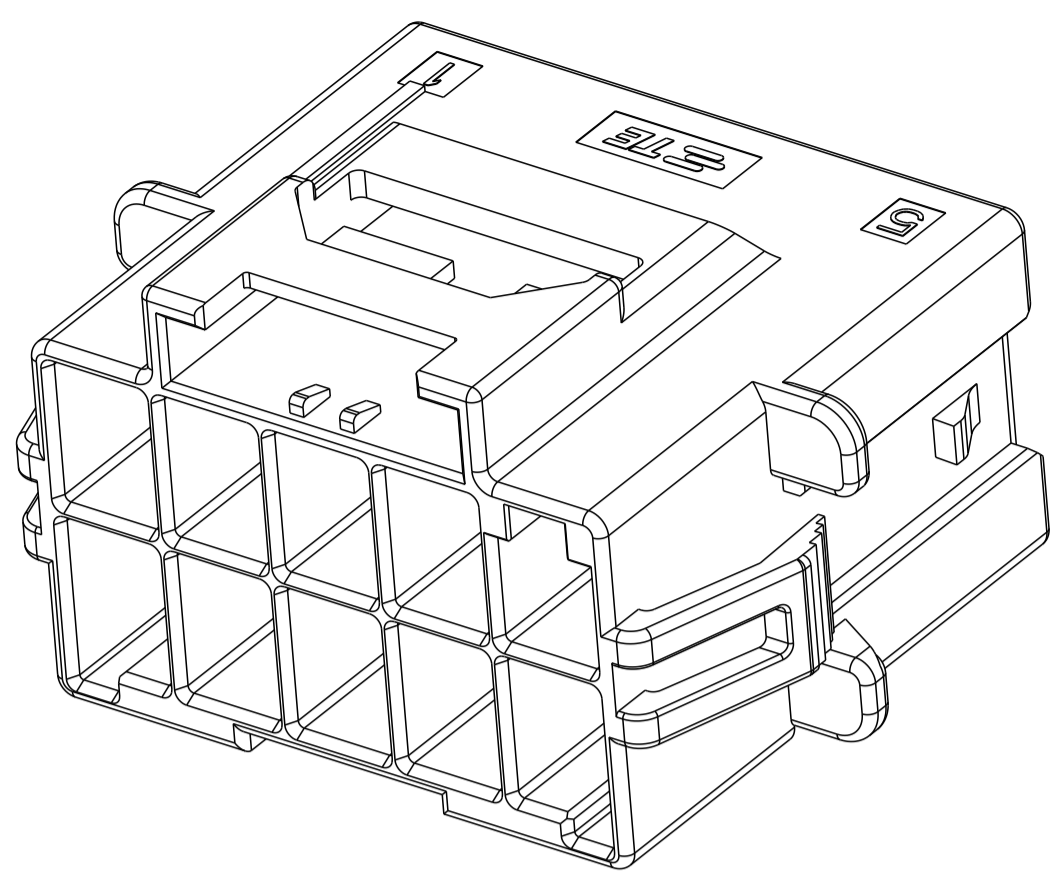

2\*5 POSITIONS

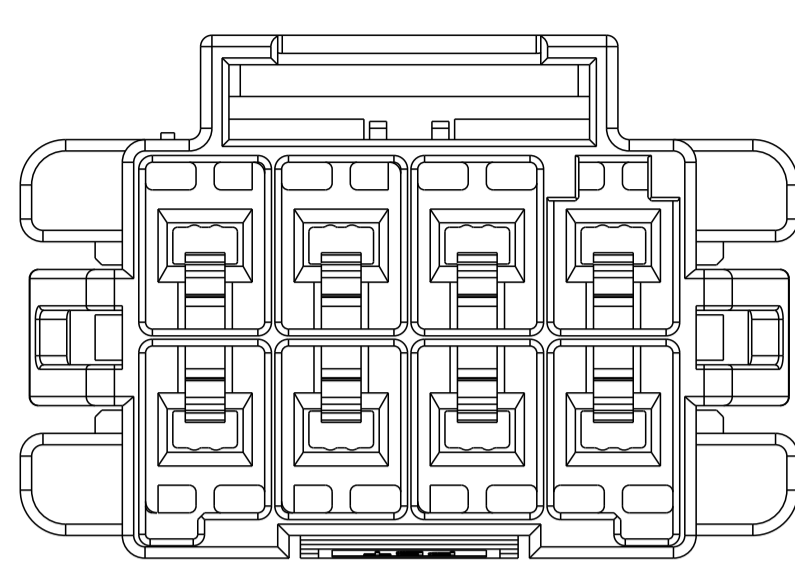
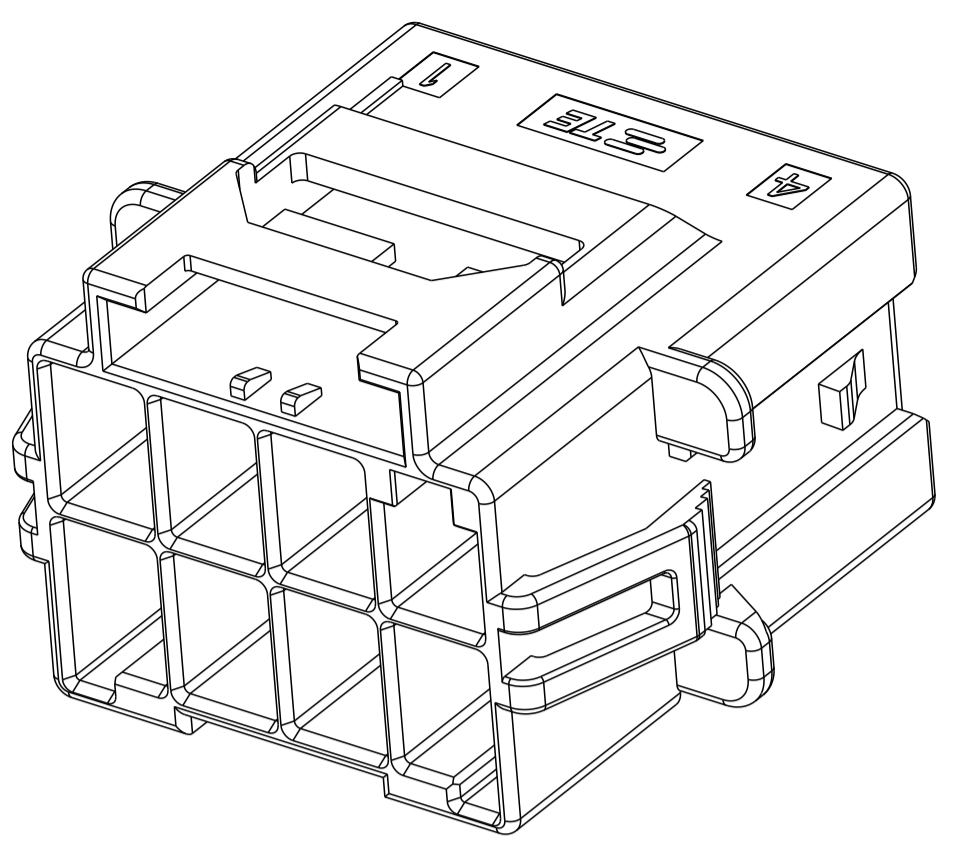

2\*4 POSITIONS

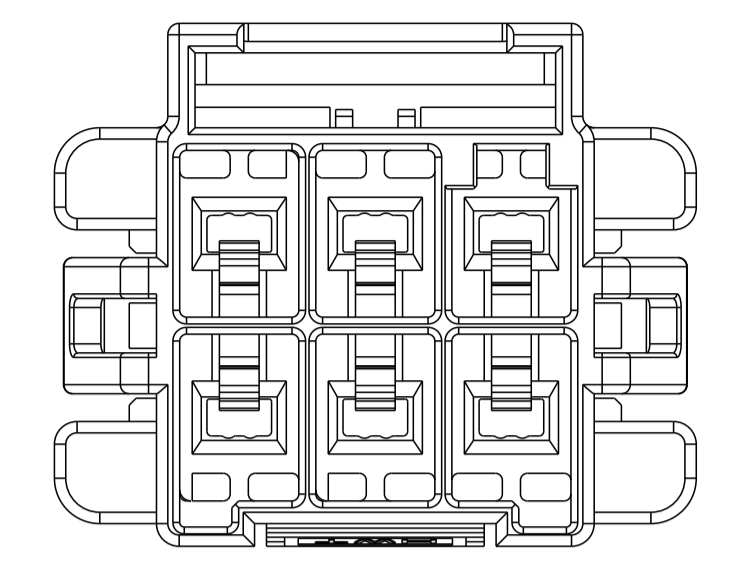
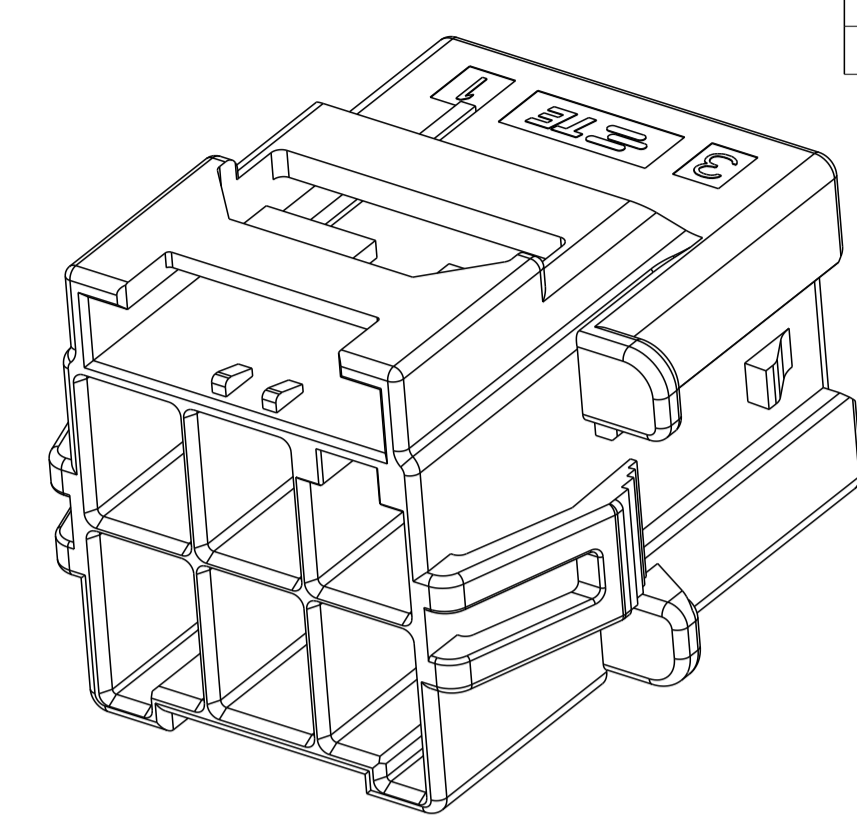

2\*3 POSITIONS

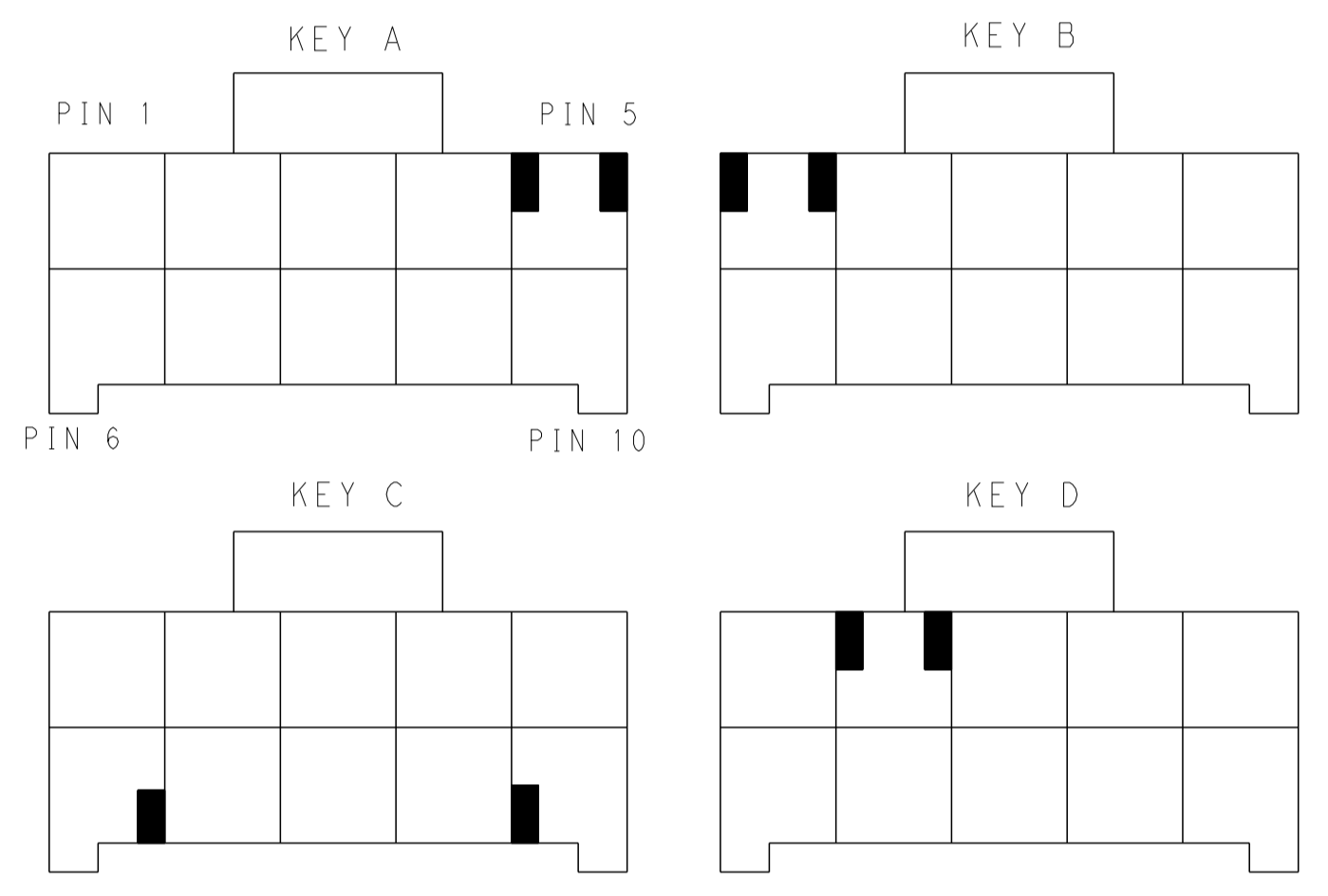

KEYING FOR 2\*5 POS.

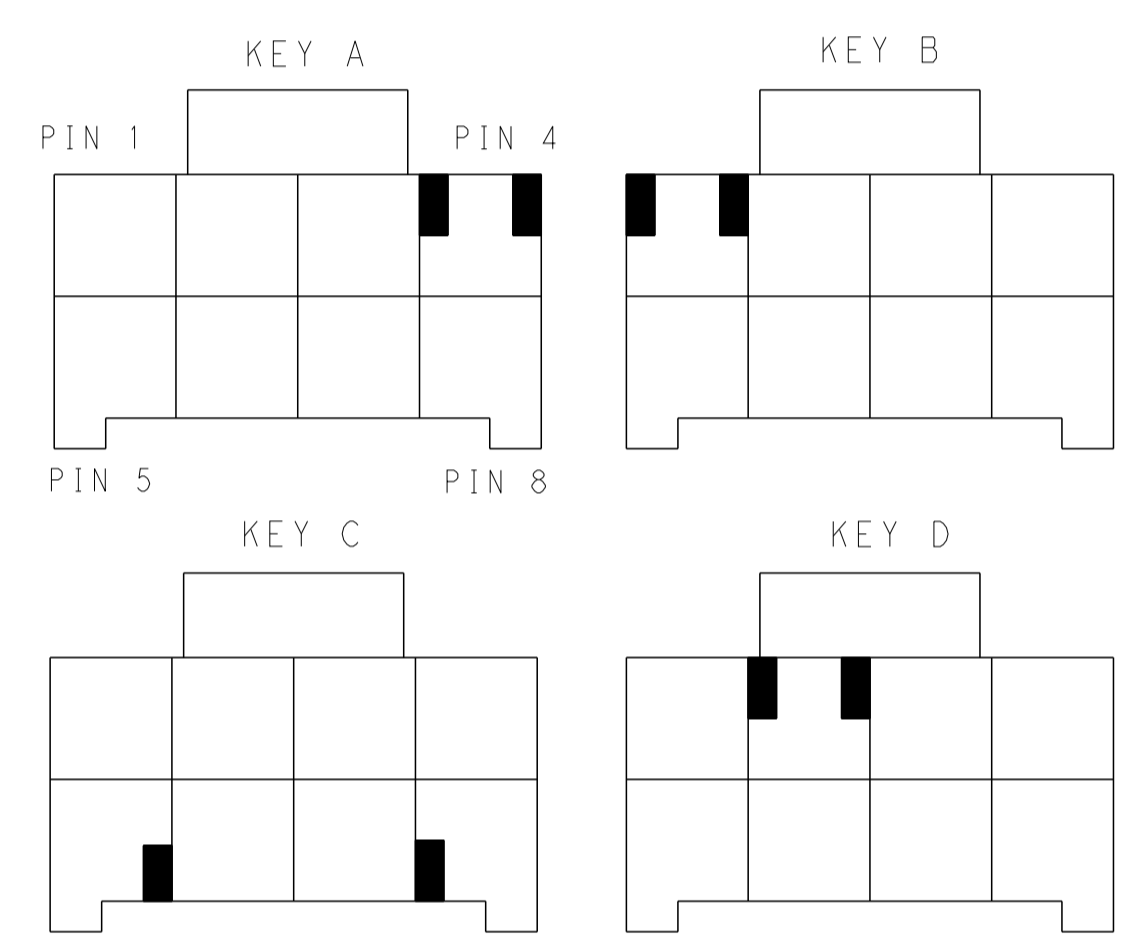

KEYING FOR 2\*4 POS.

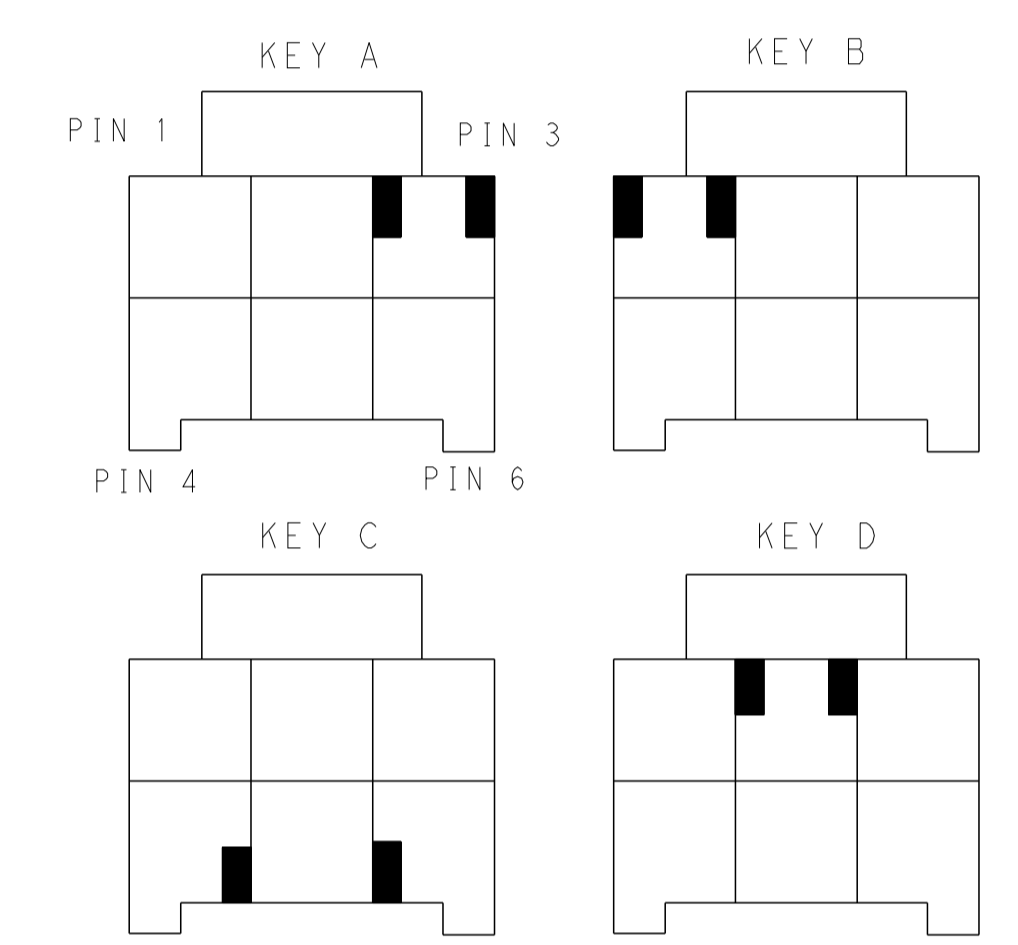

KEYING FOR 2\*3 POS.

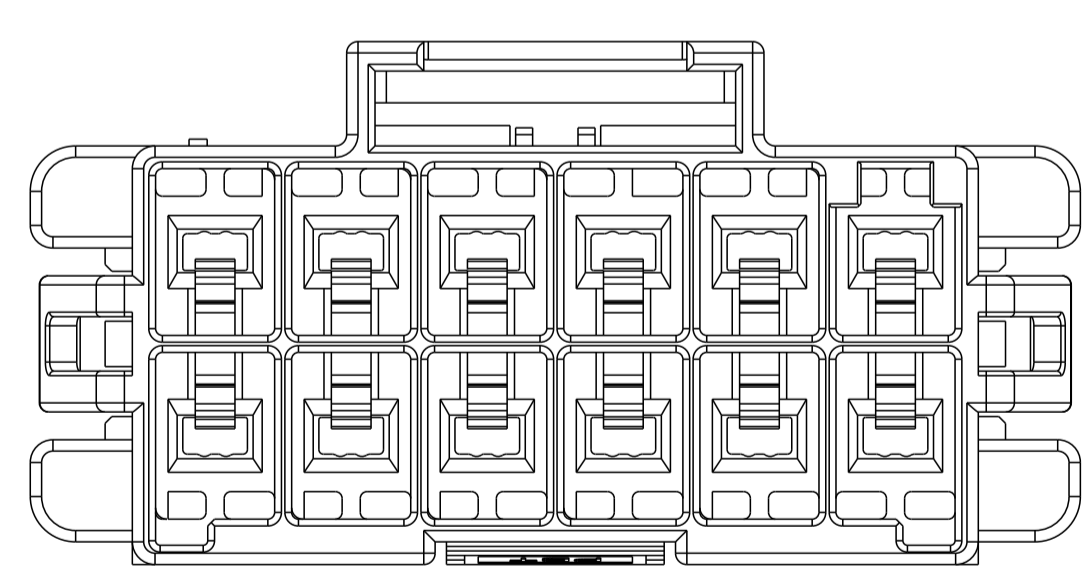
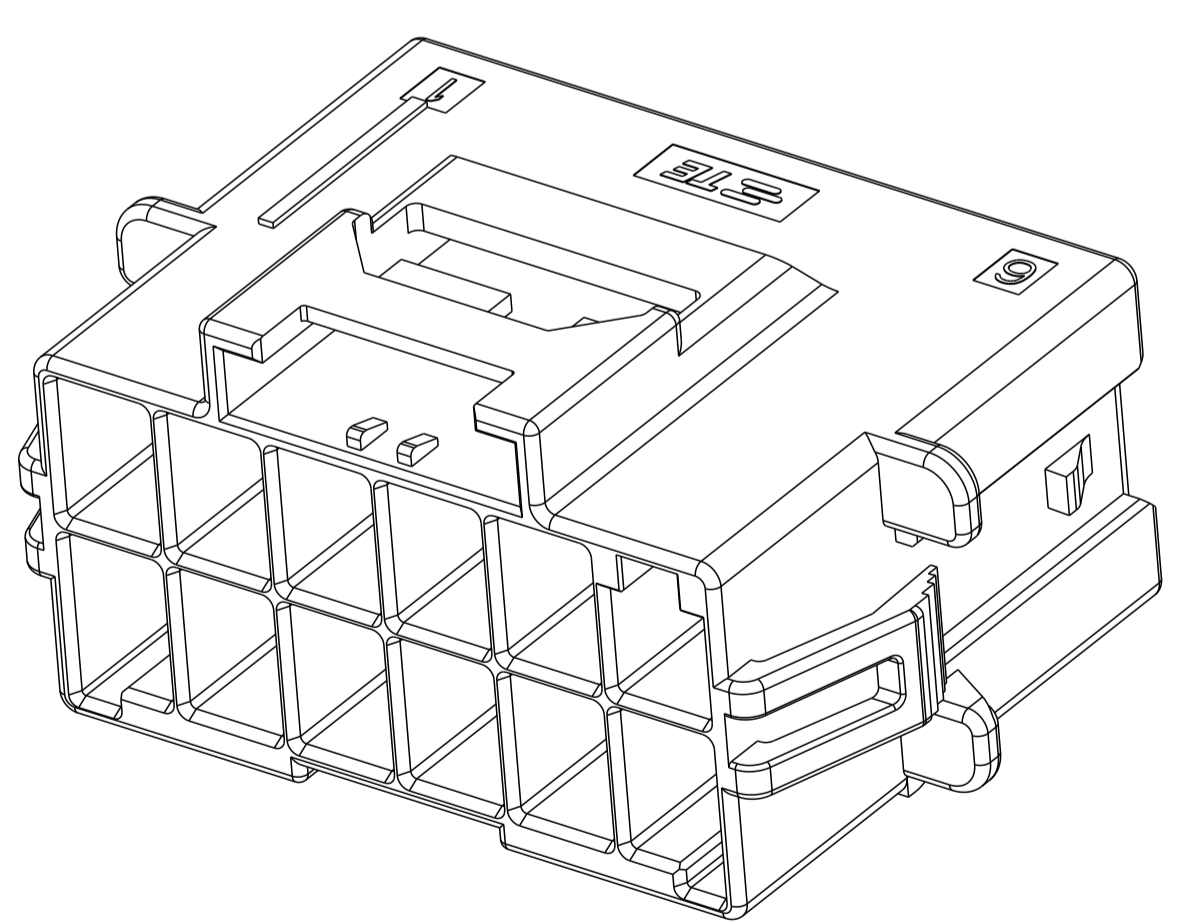

2\*6 POSITIONS

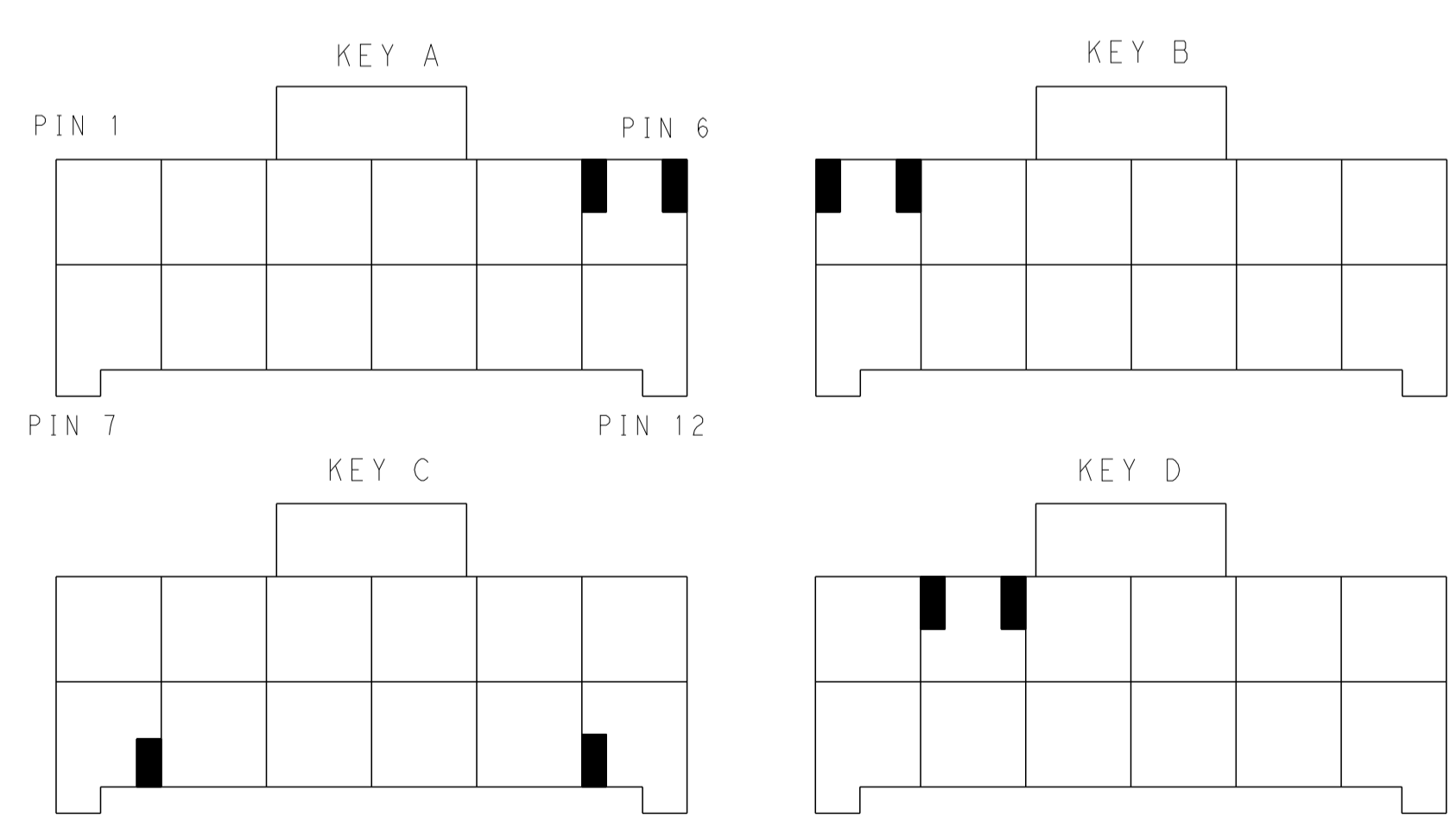

KEYING FOR 2\*6 POS.

POS.	MATERIAL	KEY	P/N
2*6	LEVEL 1	KEY A	1-1971775-6
		KEY B	2-1971775-6
		KEY C	3-1971775-6
		KEY D	4-1971775-6
LEVEL 2	6	KEY A	5-1971775-6
		KEY B	6-1971775-6
		KEY C	7-1971775-6
		KEY D	8-1971775-6
2*5	LEVEL 1	KEY A	1-1971775-5
		KEY B	2-1971775-5
		KEY C	3-1971775-5
		KEY D	4-1971775-5
LEVEL 2	6	KEY A	5-1971775-5
		KEY B	6-1971775-5
		KEY C	7-1971775-5
		KEY D	8-1971775-5

POS.	MATERIAL	KEY	P/N
2*4	LEVEL 1	KEY A	1-1971775-4
		KEY B	2-1971775-4
		KEY C	3-1971775-4
		KEY D	4-1971775-4
LEVEL 2	6	KEY A	5-1971775-4
		KEY B	6-1971775-4
		KEY C	7-1971775-4
		KEY D	8-1971775-4
2*3	LEVEL 1	KEY A	1-1971775-3
		KEY B	2-1971775-3
		KEY C	3-1971775-3
		KEY D	4-1971775-3
LEVEL 2	6	KEY A	5-1971775-3
		KEY B	6-1971775-3
		KEY C	7-1971775-3
		KEY D	8-1971775-3

THIS DRAWING IS A CONTROLLED DOCUMENT.

OWN: TOMMY WU 06JUL2012  
 CHK: TOMMY WU 06JUL2012  
 APVD: HAPYE WU 06JUL2012  
 YUHONG MAO 06JUL2012

TE Connectivity

NAME: CAP HOUSING, PANEL MOUNT, DOUBLE ROW POWER TRIPLE LOCK

SIZE: A1 CAGE CODE: 00779C DRAWING NO: 1971775

SCALE: SHEET 2 OF 2 REV G1

Customer Drawing