

Material :

- * Base: High temperature plastic UL 94V-0, Color Nature
- * Cover: High temperature plastic UL 94V-0, Color Black
- * Contact: Phosphor Bronze
- * Fixed tab: Phosphor Bronze with 2.50um(100u'') Min. Matte Tin Plated over 1.27um(50u'') Min. Nickel

Ordering Code

CF35 ** * D 0 RE -NH
 ① ② ③ ④ ⑤ ⑥ ⑦

- ① Series No.
- ② No. of Circuits 4~30PIN Enhanced version
- ③ Plating code:
 - 1= 80u''~120u''Matte Tin plated over , 50u''~80u''Min. Nicke.
 - 2= 0.03um(1.2u'') Min.Gold Flash, 50u''~80u'' MIN Nickel Underplating.
 - F= 0.03um(1.2u'') Min.Gold Flash on Contact area and Solder tails, 1.27um(50u'') Min. Nickel Underplating over all.
- ④ Contact style: D= Downside contact
- ⑤ 0= Color Nature
- ⑥ Packing: RE= Tape & Reel packing
- ⑦ -NH= For Lead Free IR Processed and Halogen Free

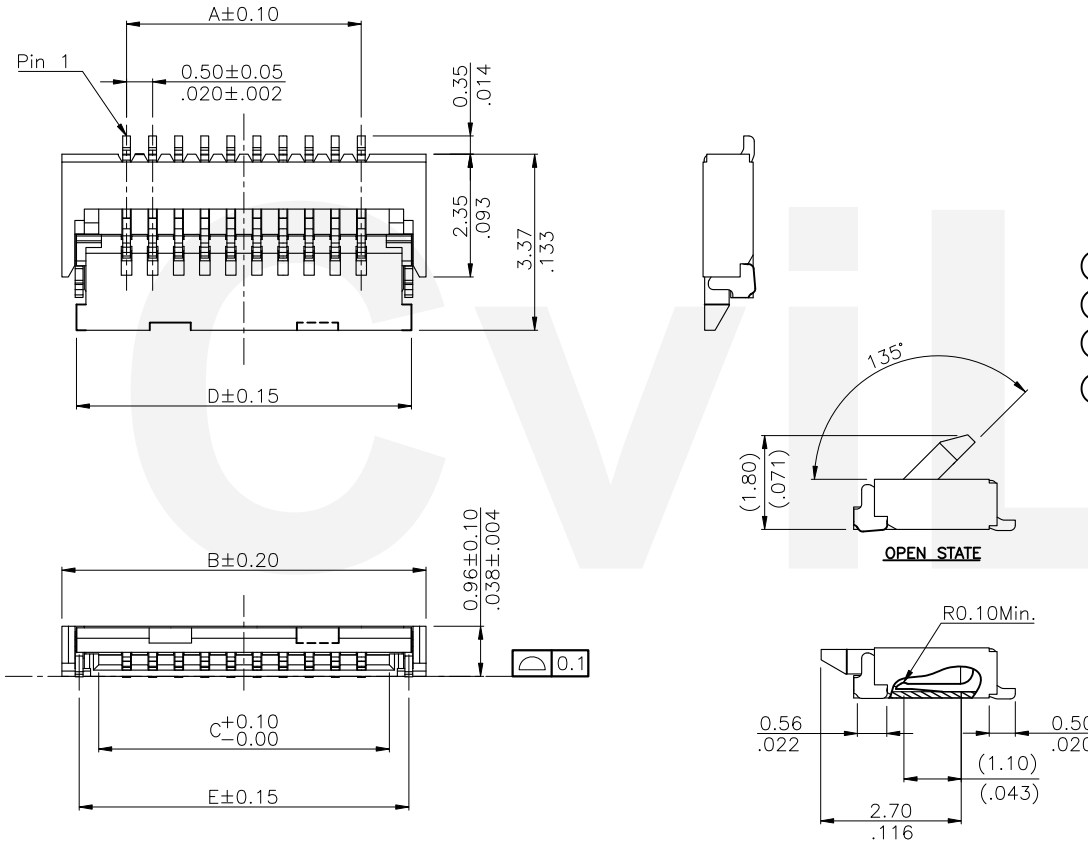

DIM A=0.5 X (No. of Circuits-1)
 DIM B=DIM A+2.50
 DIM C=DIM A+1.10
 DIM D=DIM A+1.90
 DIM E=DIM A+1.82

Halogen-Free Lead Free Process RoHS Compliant

④					DATE	UNIT: mm / inch	TITLE: 0.50mm(.020") ZIF FFC/FPC ONE-TOUCH CONNECTOR (Enhanced version)	 瀚荃股份有限公司 CviLux Corporation			
③					DATE	TOLERANCE UNLESS OTHERWISE SPECIFIED	MATERIAL:				DRAWING NO.
②					DATE	.X ± 0.20/.008 .X' ±	FINISH:	SCALE	10 / 1	SHEET	1 OF 3
①					DATE	.XX ± 0.15/.006 .X' ± 1'					
SYM	NAME	DATE	REVISIONS	APPROVED BY:	Phil	5/11-20'	.XXX ±				

CIVILUX
 2020.05.28
 ISSUED

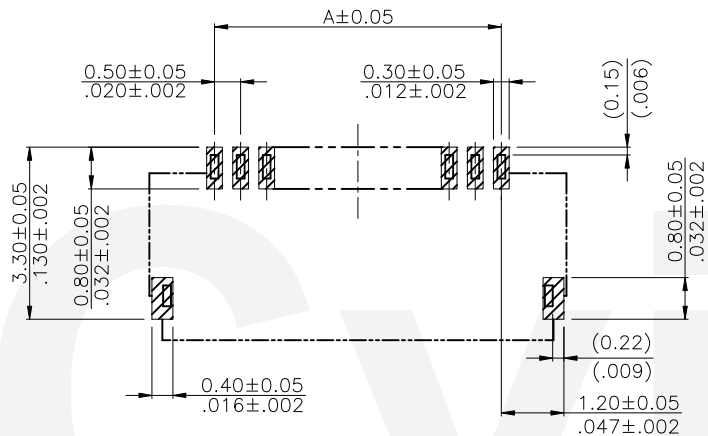

Recommended P.C. Board Layout

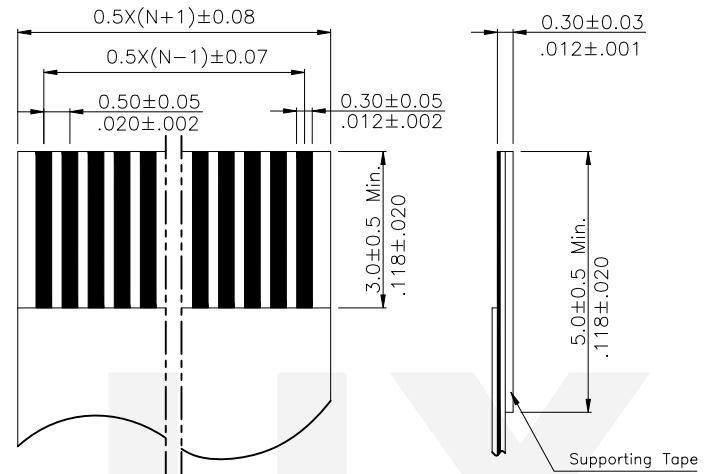

Accommodated FFC/FPC

Halogen-Free

Lead Free Process

RoHS Compliant

4					DATE	UNIT: mm / inch	TITLE: 0.50mm(.020") ZIF FFC/FPC ONE-TOUCH CONNECTOR (Enhanced version)	 瀚荃股份有限公司 CviLux Corporation
3				DRAWN BY: Hero	5/11-20'	TOLERANCE UNLESS OTHERWISE SPECIFIED	MATERIAL:	
2				ENGINEER: Hero	5/11-20'	.X ± 0.20/.008 X' ±	FINISH:	
1				CHECKED BY: Steve	5/11-20'	.XX ± 0.15/.006 X' ± 1'		
SYM	NAME	DATE	REVISIONS	APPROVED BY: Phil	5/11-20'	.XXX ±	XXX ±	DRAWING NO. CF3524SA PART NO. CF35***DORE-NH
								SCALE 10 / 1 SHEET 2 OF 3

CVILUX
2020.05.28
ISSUED

Notes:

1. 10 sprocket hole pitch cumulative tolerance ± 0.2
2. Camber not to exceed 1mm in 100mm.
3. Material: Polystyrene.
4. Pocket position relative to sprocket hole measured as true position of pocket, not pocked hole.
5. All dimensions meet EIA-481-B requirements.
6. Quantity: 3000 PCS/REEL

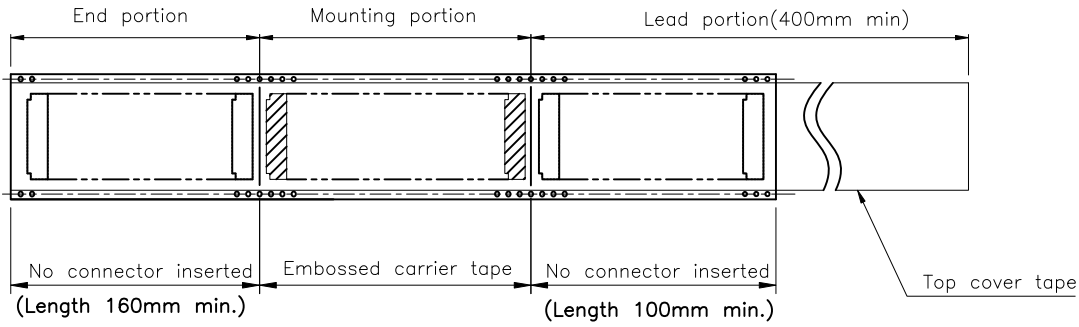

TAPE RUNNING DIRECTION

Circuits	Dimension					Packing (Reel/Carton)
	E	F	W1	W2	W3	
4-11	16.0(.630)	7.50(.295)	16.5(.650)	22.5(.885)	16.5(.650)	11
12-29	24.0(.945)	11.50(.453)	24.5(.965)	30.5(1.200)	24.5(.965)	9
30	32.0(1.260)	14.20(.559)	32.5(1.280)	38.5(1.516)	32.5(1.280)	7

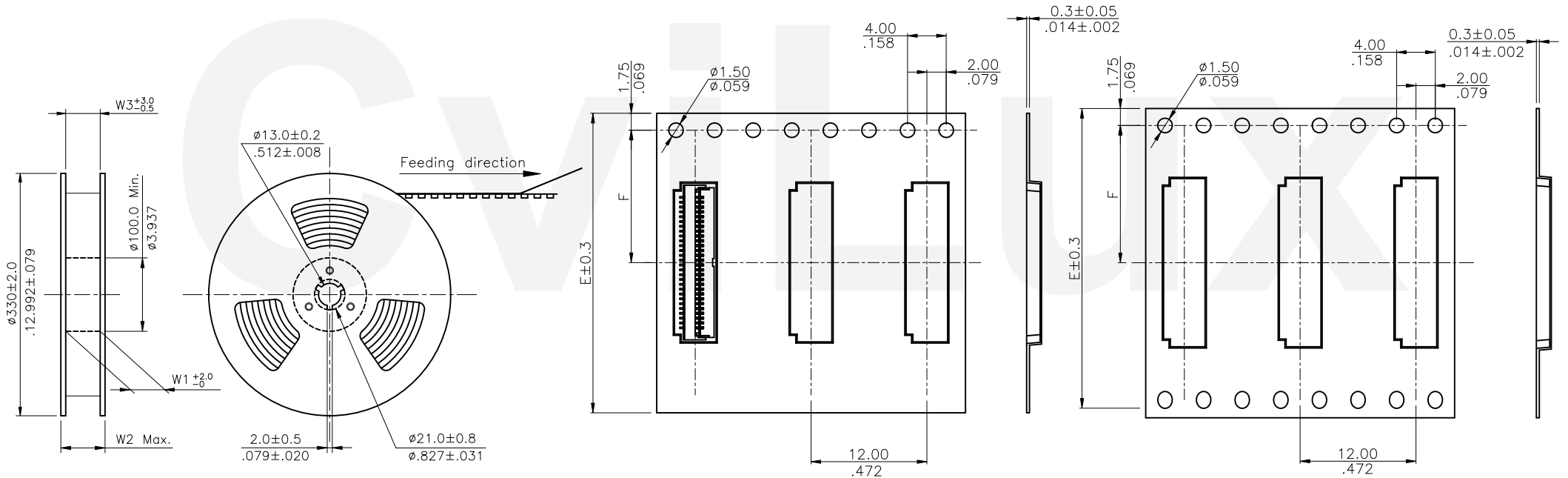

WIDTH : 16,24 mm Carrier
(SCALE 1:4)

WIDTH : 32,44 mm Carrier
(SCALE 1:4)

RoHS Compliant

4					DATE	UNIT: mm / inch	TITLE: 0.50mm(.020") ZIF FFC/FPC ONE-TOUCH CONNECTOR (Enhanced version)	 瀚荃股份有限公司 CviLux Corporation
3					DRAWN BY: Hero	5/11-20'	TOLERANCE UNLESS OTHERWISE SPECIFIED	
2					ENGINEER: Hero	5/11-20'	.X \pm 0.15/.006 X' \pm	MATERIAL:
1					CHECKED BY: Steve	5/11-20'	.XX \pm 0.10/.004 X' \pm 1'	FINISH:
SYM	NAME	DATE	REVISIONS	APPROVED BY: Phil	5/11-20'	.XXX \pm	.XX \pm	DRAWING NO. CF3524SA PART NO. CF35***DORE-NH
								SCALE 10 / 1 SHEET 3 OF 3

CVILUX
 2020.05.28
 ISSUED