

THE PRIMARY CARTON WITH A LABEL STATING "ELV AND RoHS COMPLAINT" IS LEAD FREE. CARTONS WITHOUT THIS LABEL MAY CONTAIN LEAD.

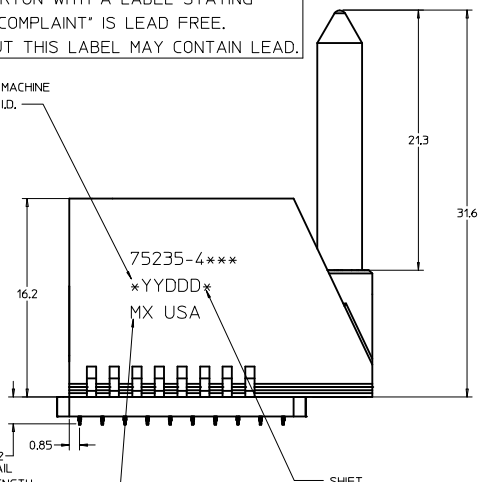

LEAD-FREE PLATING

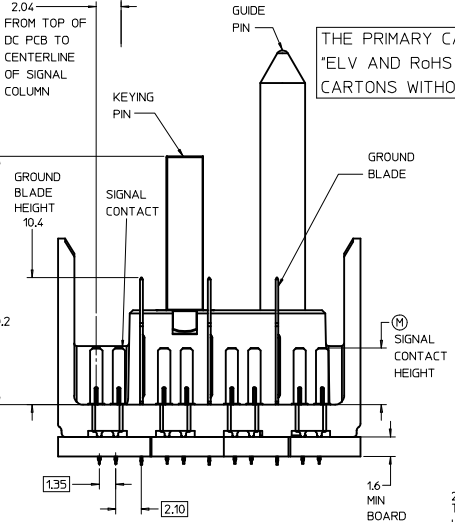
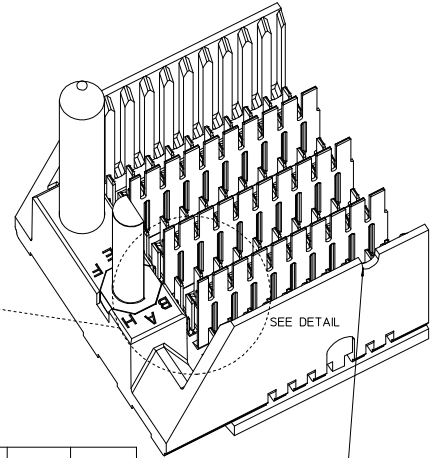
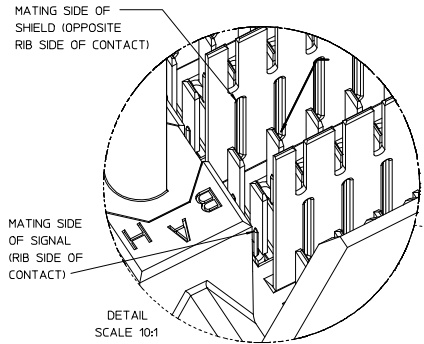

- NOTES:
1. MATERIAL: HOUSING - LIQUID CRYSTAL POLYMER (LCP) GLASS-FILLED, UL 94V-0, COLOR - GRAY, SIGNAL CONTACT AND GROUND BLADE - HIGH PERFORMANCE COPPER ALLOY.
  2. FINISHES: SELECTIVE GOLD (Au) ON CONTACT AREA, SELECTIVE MATTE TIN (Sn) ON PCB TAILS, NICKEL (Ni) OVERALL.
  3. THIS PART CONFORMS TO MOLEX PRODUCT SPECIFICATION PS-75221-999.
  4. FOR MIXED CONTACT MATING LENGTHS CONSULT MOLEX FOR AVAILABILITY. CONTACT PAIRS MUST BE THE SAME LENGTH.
  5. FOR SPECIFIC PART NUMBER AND MATING INFORMATION PLEASE REFER TO CHART.
  6. PACKAGE PER PK-70873-563.
  7. MARK PART NUMBER AND DATE CODE APPROXIMATELY WHERE SHOWN.
  8. OPTIONAL HOLE LOCATION FOR GROUNDED GUIDE PIN OR ADDITIONAL GUIDE PIN SUPPORT, FOR GROUNDED GUIDE PIN, HOLE TO BE PLATED, DRILL SIZE Ø2.58, PAD SIZE Ø5.50
  9. THESE PART CONFORM TO MOLEX COSMETIC SPECIFICATION PS-45499-002 CLASS B.
  10. MAPS (MOLEX ADVANCED PLATING SYSTEM).

SEE NOTE 7  
MODULE ORIENTATION RIGHT = 4  
75235-4 \* \* \*  
COLUMN 1=10 COL 2=25 COL  
KEYING ORIENTATION 0=NONE 1=A 2=B ETC...

PIN LENGTH DIM "M"	GOLD (Au) THICKNESS micrometers
0-3.55 mm	0.25 (MAPS)
1-4.55 mm	
2-5.55 mm	
3-3.55 mm	0.76
4-4.55 mm	
5-5.55 mm	
7-3.55 mm	1.27
8-4.55 mm	
9-5.55 mm	

ASSY PART NO.	K	L	P	TOTAL NO. OF DIFFERENTIAL PAIRS
75235-41**	9	16.65	24.78	40
75235-42**	24	44.40	52.55	100

P/N 75235-( )	---0*	---1*	---2*	---3*	---4*	---5*	---6*	---7*	---8*
KEYING PIN ORIENTATION									

<b>REV TO LEAD-FREE</b> EC NO: UCP 2013-0690 DRAWINGS 2012/09/06 CHYKMOLE 2012/09/06 APPROX MILLER 2012/12/05 REV DESCRIPTION	QUALITY SYMBOLS ∇=0 ∇=0 ∇=0	GENERAL TOLERANCES (UNLESS SPECIFIED) DIM mm INCH 4 PLACES ±.05 ±.002 3 PLACES ±.05 ±.002 2 PLACES ±.05 ±.002 1 PLACE ±.05 ±.002 0 PLACE ±.05 ±.002 ANGULAR ±1/2° DRAFT WHERE APPLICABLE MUST REMAIN WITHIN DIMENSIONS	DIMENSION STYLE MM ONLY DRAWN BY DATE NMARTIN 2003/12/16 CHECKED BY DATE SREED 2003/12/16 APPROVED BY DATE CBIXLER 2003/12/16	SCALE 5:1 DESIGN UNITS METRIC THIRD ANGLE PROJECTION	TITLE GBX 4-PAIR LF RIGHT END BACKPLANE SALES ASSEMBLY <b>molex</b> MATERIAL NO. SD-75235-410 DOCUMENT NO.	SHEET NO. 1 OF 1
	THIS DRAWING CONTAINS INFORMATION THAT IS PROPRIETARY TO MOLEX INCORPORATED AND SHOULD NOT BE USED WITHOUT WRITTEN PERMISSION					