

PI3USB221EQ

High-Speed USB2.0 1:2 Multiplexer/DeMultiplexer Switch with Signal Enable

Features

- V_{DD} Operation at 2.5 V and 3.3 V
 - V_{I/O} Accepts Signals up to 5.5 V
 - 1.8-V Compatible Control-Pin Inputs
 - Low-Power Mode When \overline{OE} Is Disabled (2 μ A)
 - r_{ON} = 6 Ω Maximum
 - Δ r_{ON} = 0.2 Ω Typical
 - C_{io(on)} = 4pF Typical
 - Support Over Voltage Protection
 - Low Power Consumption (50 μ A Maximum)
 - ESD Performance
 - IO Pins
 - 12KV HBM
 - 1KV CDM
 - +/-8KV contact Discharge (IEC61000-4-2)
 - VDD, GND, S, \overline{OE} Pins
 - 4KV HBM
 - 1KV CDM
 - High Bandwidth: 1.6 GHz Typical
 - Automotive Grade 1 temperature range: -40 to 125°C
 - Totally Lead-Free & Fully RoHS Compliant (Notes 1 & 2)
 - Halogen and Antimony Free. "Green" Device (Note 3)
 - The PI3USB221EQ is suitable for automotive applications requiring specific change control; this part is AEC-Q100 qualified, PPAP capable, and manufactured in IATF 16949 certified facilities.
- <https://www.diodes.com/quality/product-definitions/>
- Packaging (Pb-free & Green):
 - 10-contact, UQFN (ZUA10)

Applications

- Routes Signals for USB 1.0, 1.1, and 2.0
- Mobile Industry Processor Interface (MIPI) Signal Routing

Description

The PI3USB221EQ is a high-bandwidth switch specially designed for the switching of high-speed USB 2.0 signals in handset and consumer applications, such as cell phones, digital cameras, and notebooks with hubs or controllers with limited USB I/Os.

The wide bandwidth (1.1 GHz) of this switch allows signals to pass with minimum edge and phase distortion. The device multiplexes differential outputs from a USB host device to one of two corresponding outputs. The switch is bidirectional and offers little or no attenuation of the high-speed signals at the outputs.

It is designed for low bit-to-bit skew and high channel-to-channel noise isolation, and is compatible with various standards, such as high-speed USB 2.0 (480 Mbps).

The PI3USB221EQ offer over voltage protection for the D+/D- pins as per the USB 2.0 specification. with the chip power on or off if D+/D- pins are shorted to VBus (5V+/-5%), a less than 3.8V (typical) signal will transmit through 1D+/1D- and 2D+/2D- output.

Truth Table

S	\overline{OE}	Function
X	H	Disconnect
L	L	D = 1D
H	L	D = 2D

Block Diagram

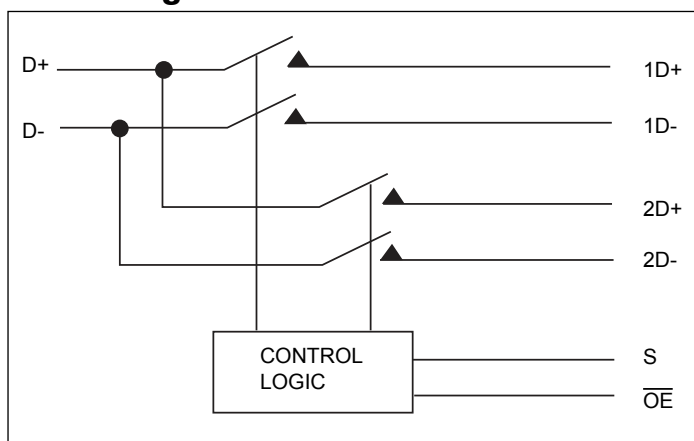

Notes:

1. No purposely added lead. Fully EU Directive 2002/95/EC (RoHS), 2011/65/EU (RoHS 2) & 2015/863/EU (RoHS 3) compliant.
2. See <https://www.diodes.com/quality/lead-free/> for more information about Diodes Incorporated's definitions of Halogen- and Antimony-free, "Green" and Lead-free.
3. Halogen- and Antimony-free "Green" products are defined as those which contain <900ppm bromine, <900ppm chlorine (<1500ppm total Br + Cl) and <1000ppm antimony compounds.

Pin Configuration

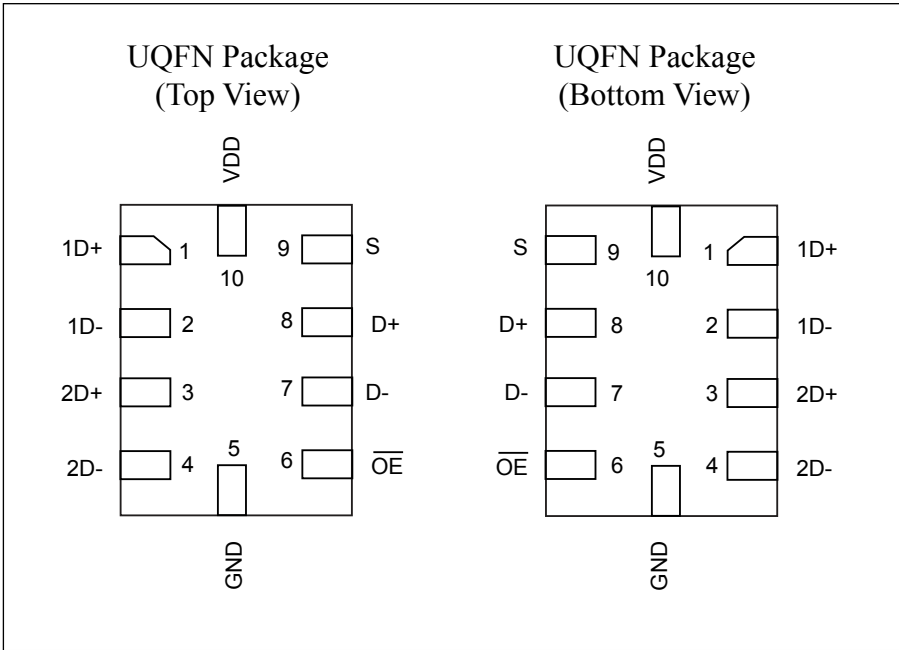

Pin Description

Name	Description
\overline{OE}	Active LOW, Output enable
S	Select input
D	COM port
nD	I/O for USB data path (port 1 and port 2)

Absolute Maximum Ratings⁽¹⁾

Over operating free-air temperature range (unless otherwise noted)

V _{DD} Supply Voltage Range	-0.5V to 4.6V
V _{IN} Control Input Voltage Range ^(2, 3)	-0.5V to 5.5V
V _{I/O} Switch I/O Voltage Range ^(2, 3, 4)	-0.5V to 5.5V
I _{IK} Control Input Clamp Current (V _{IN} < 0)	-50mA
I _{I/OK} I/O Port Clamp Current (V _{I/O} < 0)	-50mA
I _{I/O} ON-state Switch Current ⁽⁵⁾	±120mA
Continuous Current through V _{DD} or GND	±100mA
θ _{JA} Package Thermal Impedance	
TDFN Package	243°C/W
T _{stg} Storage Temperature Range	-65 to 150°C
T _j Junction Temperature	150°C

Notes:

1. Stresses beyond those listed under "absolute maximum ratings" may cause permanent damage to the device. These are stress ratings only, and functional operation of the device at these or any other conditions beyond those indicated under "recommended operating conditions" is not implied. Exposure to absolute-maximum-rated conditions for extended periods may affect device reliability.
2. All voltages are with respect to ground, unless otherwise specified.
3. The input and output voltage ratings may be exceeded if the input and output clamp-current ratings are observed.
4. VI and VO are used to denote specific conditions for VI/O.
5. II and IO are used to denote specific conditions for II/O.
6. The package thermal impedance is calculated in accordance with JESD 51-7.

Recommended Operating Conditions⁽¹⁾

Symbol	Description	Parameter	Min.	Max.	Unit
V _{DD}	Supply voltage		2.3	3.6	V
V _{IH}	High-level control input voltage	V _{DD} = 2.3 V to 2.7 V	1.3	-	
		V _{DD} = 2.7 V to 3.6 V	1.4	-	
V _{IL}	Low-level control input voltage	V _{DD} = 2.3 V to 2.7 V		0.6	
		V _{DD} = 2.7 V to 3.6 V		0.6	
V _{I/O}	Data input/output voltage		0	4.6	
T _A	Operating free-air temperature		-40	125	°C

Note:

1. All unused control inputs of the device must be held at V_{DD} or GND to ensure proper device operation.

Electrical Characteristics

Over operating free-air temperature range (unless otherwise noted)

Parameter	Testing Conditions	Min.	Typ.	Max.	Unit	
V_{IK}	$V_{DD} = 3.6V, 2.7V, I_I = -18 \text{ mA}$			-1.2	V	
I_{IN}	Control Inputs $V_{DD} = 3.6V, 2.7V, 0V, V_{IN} = 0V \text{ to } 3.6V$			± 1	μA	
$I_{OZ}^{(3)}$	$V_{DD} = 3.6V, 2.7V, V_{IN} = V_{DD} \text{ or } GND,$ $V_O = 0V \text{ to } 3.6V, V_I = 0V, \text{ Switch OFF}$			± 1		
$I_{(OFF)}$	$V_{DD} = 0V$	$V_{I/O} = 0V \text{ to } 3.6V$		± 2		
		$V_{I/O} = 0 \text{ to } 2.7V$		± 1		
I_{CC}	$V_{DD} = 3.6V, 2.7V, V_{IN} = V_{DD} \text{ or } GND,$ $I_{I/O} = 0 \text{ V, Switch ON or OFF}$		25	50		
I_{CC} (low power mode)	$V_{DD} = 3.6V, 2.7V, V_{IN} = V_{DD} \text{ or } GND,$ Switch disabled, (OE in high state)			4		
$D I_{CC}^{(4)}$	Control Inputs	$V_{DD} = 2.7V, S$ sweeps from 1.4V to 3.3V, OE/ = 0V		15		
		$V_{DD} = 2.7V, OE/$ sweeps from 1.4V to 3.3V, S = 0V		0.75		
C_{IN}	Control Inputs $V_{DD} = 3.3V, 2.5V, V_{IN} = 3.3V \text{ or } 0V$		1	2	pF	
$C_{io(OFF)}$	$V_{DD} = 3.3V, 2.5V, V_{IN} = 3.3V \text{ or } 0V, \text{ Switch OFF}$		2	3		
$C_{io(ON)}$	$V_{DD} = 3.3V, 2.5V, V_{IN} = 3.3V \text{ or } 0V, \text{ Switch ON}$		4	6		
$r_{ON}^{(5)}$	$V_{DD} = 3V, 2.3V$	$V_I = 0V, I_O = 30 \text{ mA}$		4		
		$V_I = 2.4V, I_O = -15 \text{ mA}$		7		
$D r_{ON}^{(6)}$	$V_{DD} = 3V, 2.3V$	$V_I = 0V, I_O = 30 \text{ mA}$		0.2		
		$V_I = 1.7V, I_O = -15 \text{ mA}$		0.2		
$r_{ON(Flat)}$	$V_{DD} = 3V, 2.3V$	$V_I = 0V, I_O = 30 \text{ mA}$		1		
		$V_I = 1.7V, I_O = -15 \text{ mA}$		1		
V_{pass}	$V_{DD} = 2.5 - 3.3V$	$V_{IN} > 3.8V, I_O = 10\mu A$	2.8	3.8	4.2	V

Notes:

- V_{IN} and I_{IN} refer to control inputs. $V_I, V_O, I_I,$ and I_O refer to data pins.
- All typical values are at $V_{DD} = 3.3 \text{ V}$ (unless otherwise noted), $T_A = 25^\circ C$.
- For I/O ports, the parameter IOZ includes the input leakage current.
- This is the increase in supply current for each input that is at the specified TTL voltage level, rather than V_{DD} or GND.
- Measured by the voltage drop between the input and output terminals at the indicated current through the switch. ON-state resistance is determined by the lower of the voltages of the two terminals.
- Dron is delta Ron between channels

Dynamic Electrical Characteristics

 Over operating range, $T_A = -40^\circ C \text{ to } 85^\circ C, V_{DD} = 3.3 \text{ V} \pm 10\%, GND = 0V$

Symbol	Parameter	Test Conditions	Typ. ⁽¹⁾	Unit
X_{TALK}	Crosstalk	$R_L = 50\Omega, f = 250 \text{ MHz}$	-40	dB
O_{IRR}	OFF isolation	$R_L = 50\Omega, f = 250 \text{ MHz}$	-41	
BW	Bandwidth (-3 dB)	$R_L = 50\Omega$	1.6	GHz

Note:

- For Max or Min conditions, use the appropriate value specified under Electrical Characteristics for the applicable device type.

Switching Characteristics

Over operating range, $T_A = -40^{\circ}\text{C}$ to 85°C , $V_{DD} = 3.3\text{ V} \pm 10\%$, $\text{GND} = 0\text{V}$

Symbol	Parameter	Min.	Typ. ⁽¹⁾	Max.	Unit
t_{pd}	Propagation Delay ^(2,3)		0.25		ns
t_{ON}	Line enable time	S to D, nD		125	
		$\overline{\text{OE}}$ to D, nD		100	
t_{OFF}	Line disable time	S to D, nD		12	
		$\overline{\text{OE}}$ to D, nD		12	
$t_{SK(O)}$	Output skew between center port to any other port ⁽²⁾		0.1	0.2	
$t_{SK(P)}$	Skew between opposite transitions of the same output ($t_{PHL} - t_{PLH}$) ⁽²⁾		0.1	0.2	
t_{VPASS}	OVP response time		53		ns

Notes:

1. For Max or Min conditions, use the appropriate value specified under Electrical Characteristics for the applicable device type.
2. Specified by design
3. The switch contributes no propagational delay other than the RC delay of the on resistance of the switch and the load capacitance. The time constant for the switch alone is of the order of 0.25 ns for 10-pF load. Since this time constant is much smaller than the rise/fall times of typical driving signals, it adds very little propagational delay to the system. Propagational delay of the bus switch, when used in a system, is determined by the driving circuit on the driving side of the switch and its interactions with the load on the driven side.

Application Information

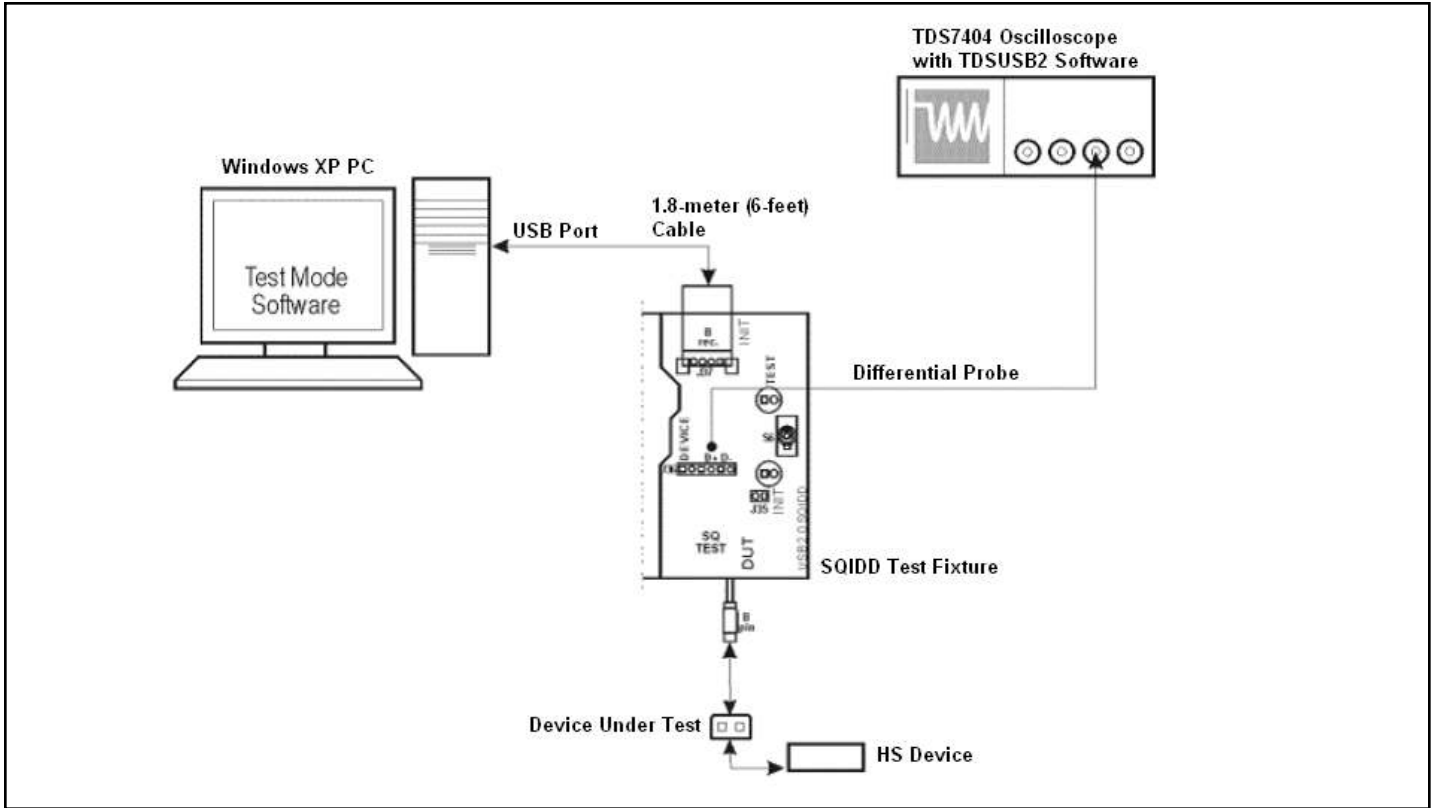
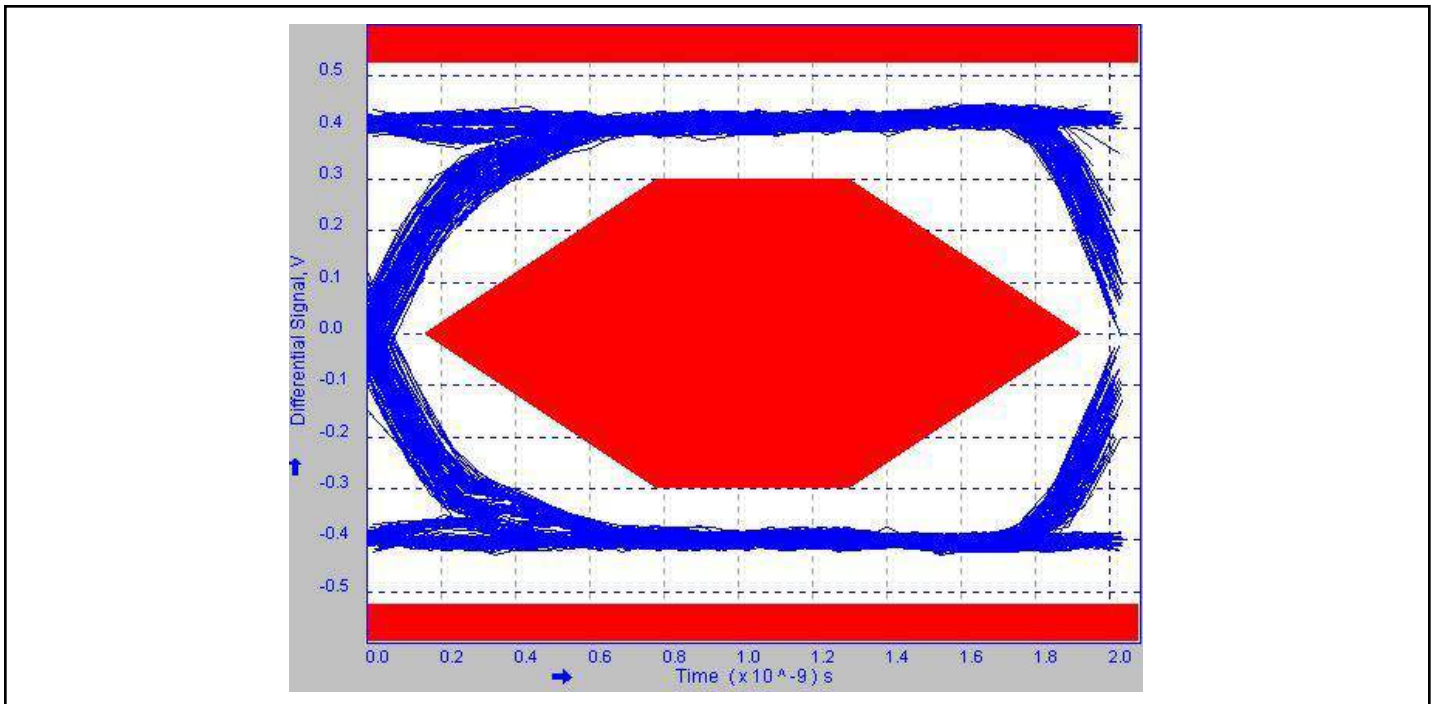

Figure 1: HS Eye Test Setup

Test Result



Test Result: High-speed, Up-stream, Near-end Eye of PI3USB221EQ

Parameter Measurement Information

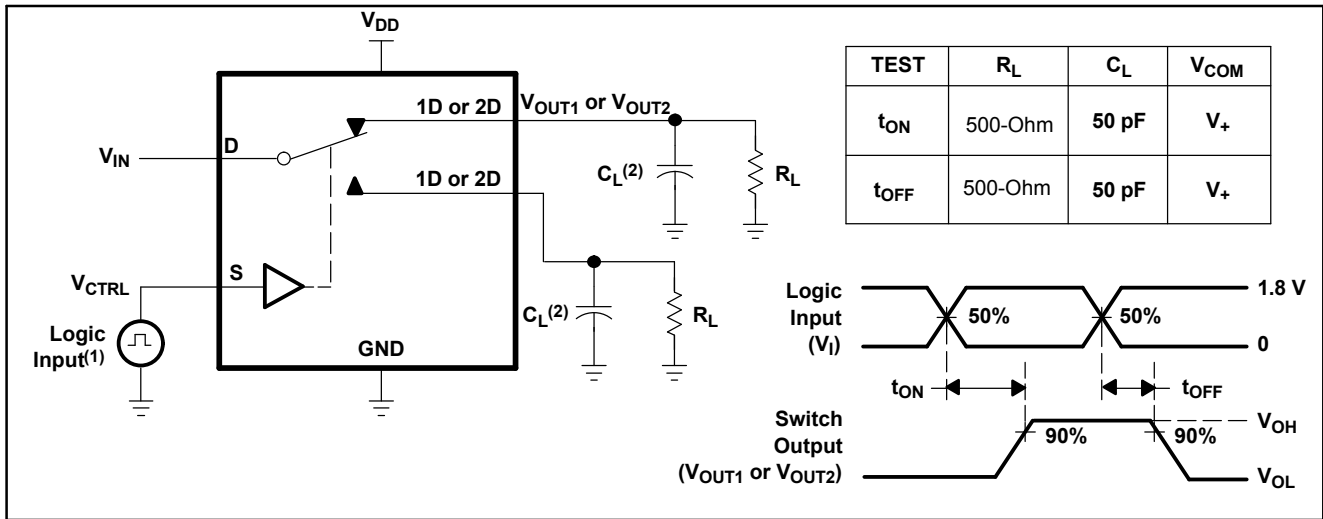

- (1) All input pulses are supplied by generators having the following characteristics: PRR ≤ 10 MHz, Z_O = 50-Ohm, t_r < 5 ns, t_f < 5 ns.
- (2) C_L includes probe and jig capacitance.

Figure 2. Turn-On (t_{ON}) and Turn-Off Time (t_{OFF})

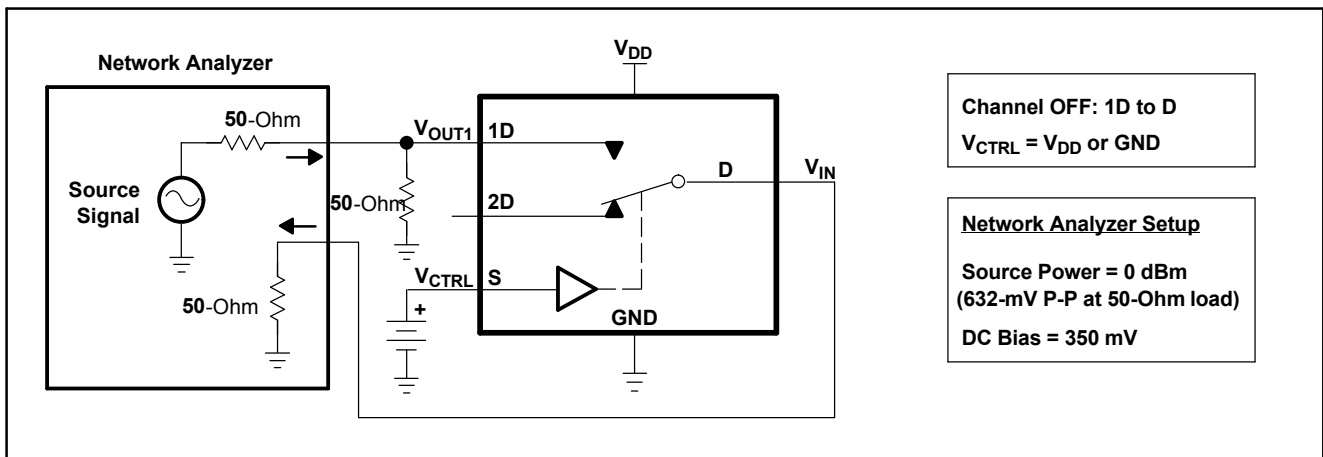

Figure 3. OFF Isolation (O_{ISO})

PI3USB221EQ

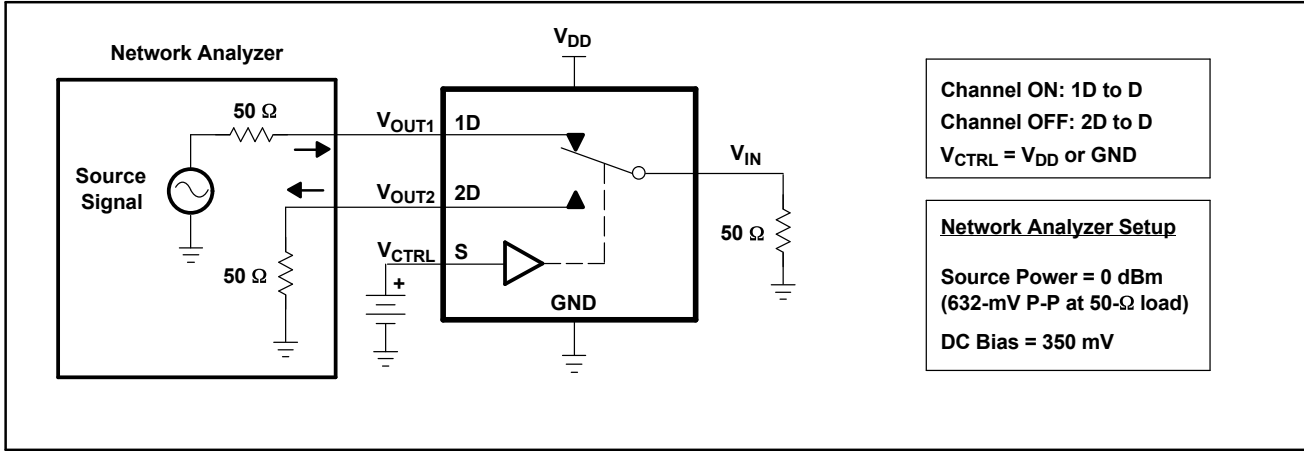

Figure 4. Crosstalk (X_{TALK})

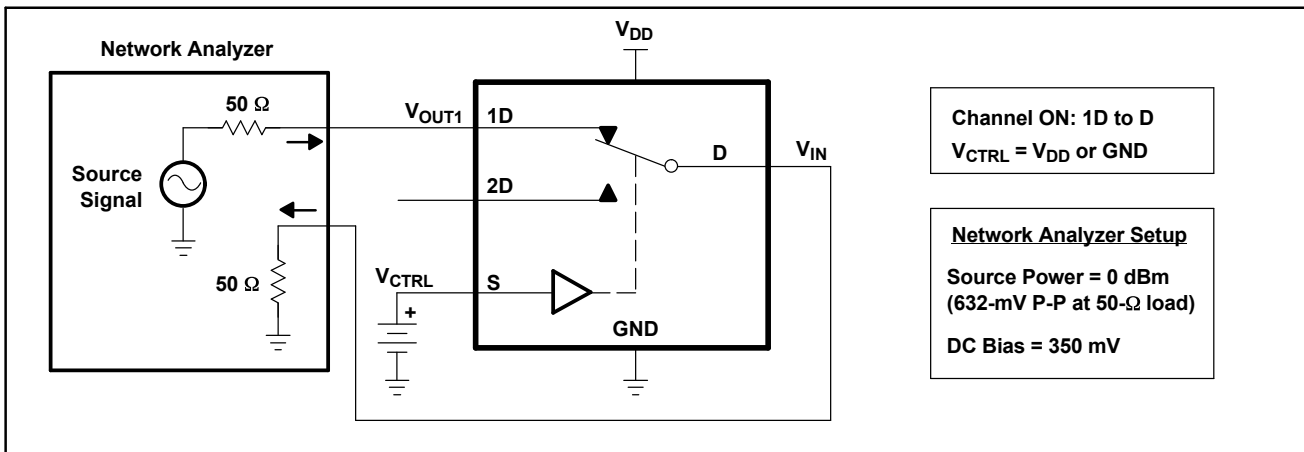

Figure 5. Bandwidth (BW)

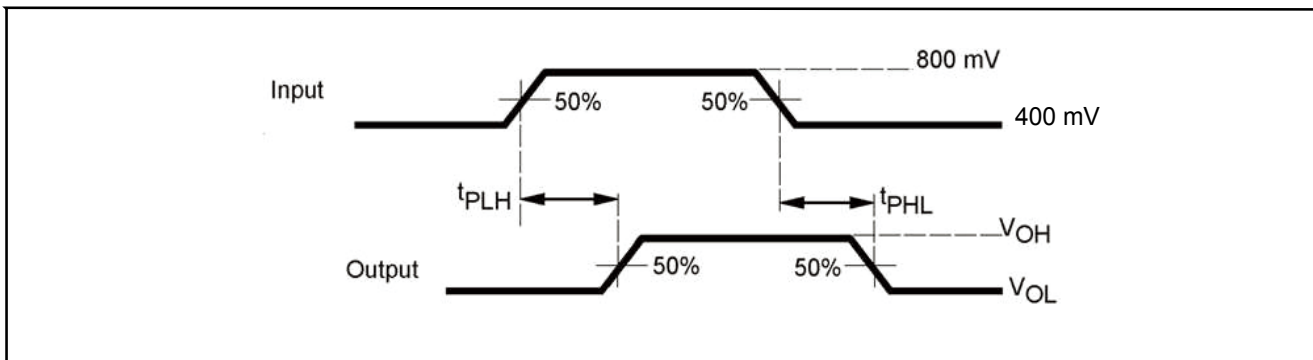

Figure 6. Propagation Delay

PI3USB221EQ

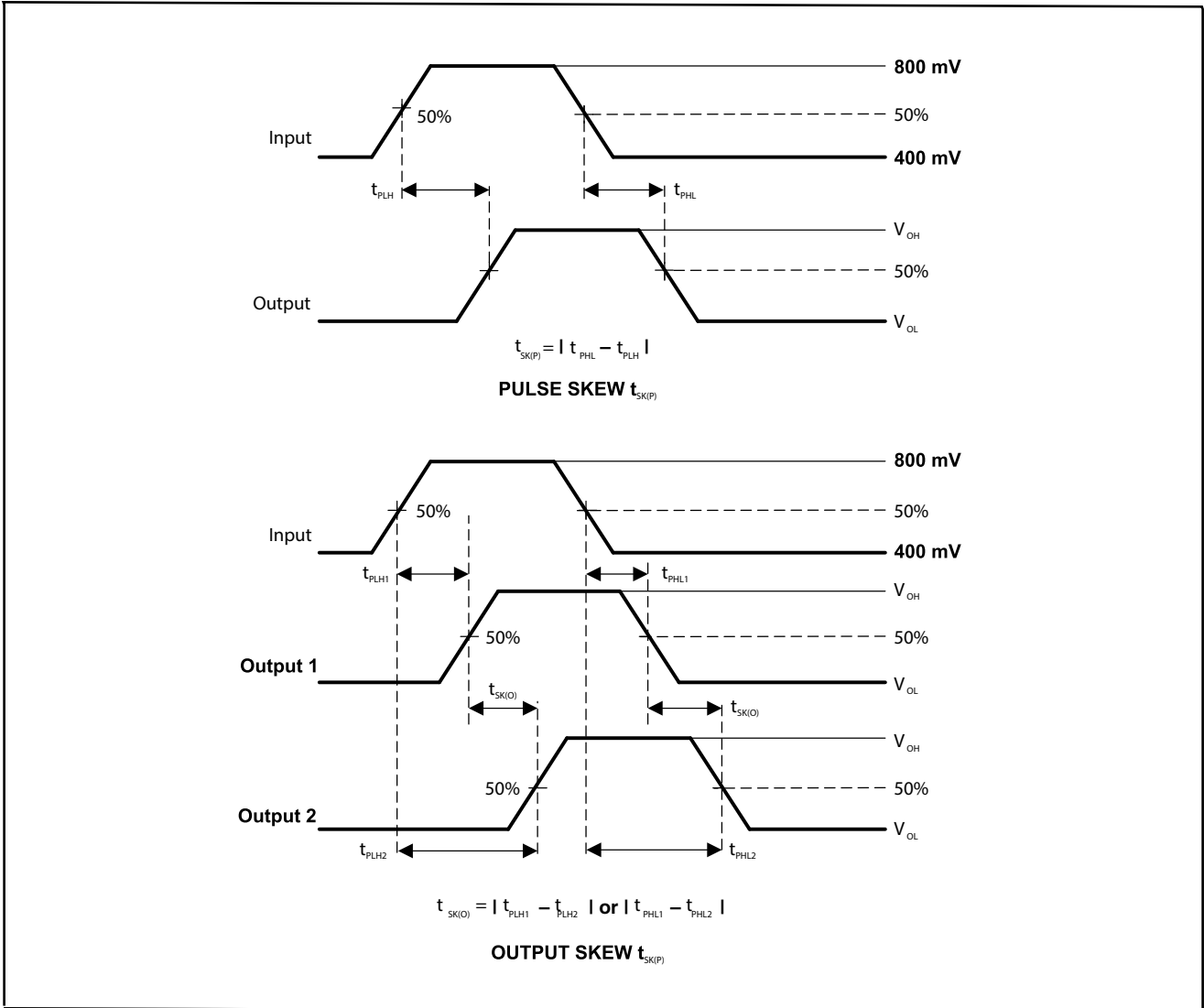

Figure 7. Skew Test

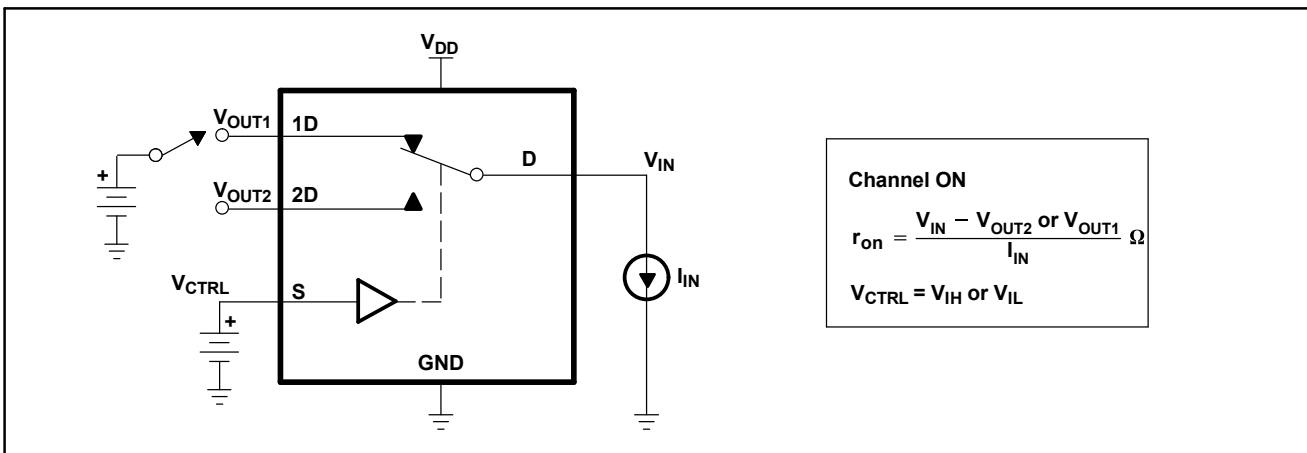

Figure 8. ON-State Resistance (r_{on})

PI3USB221EQ

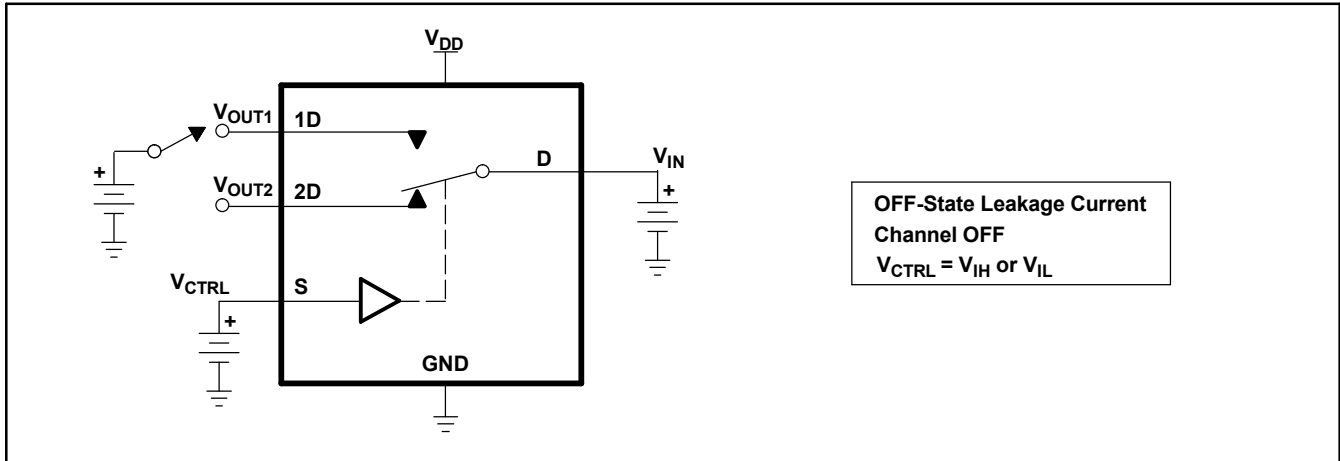

Figure 9. OFF-State Leakage Current

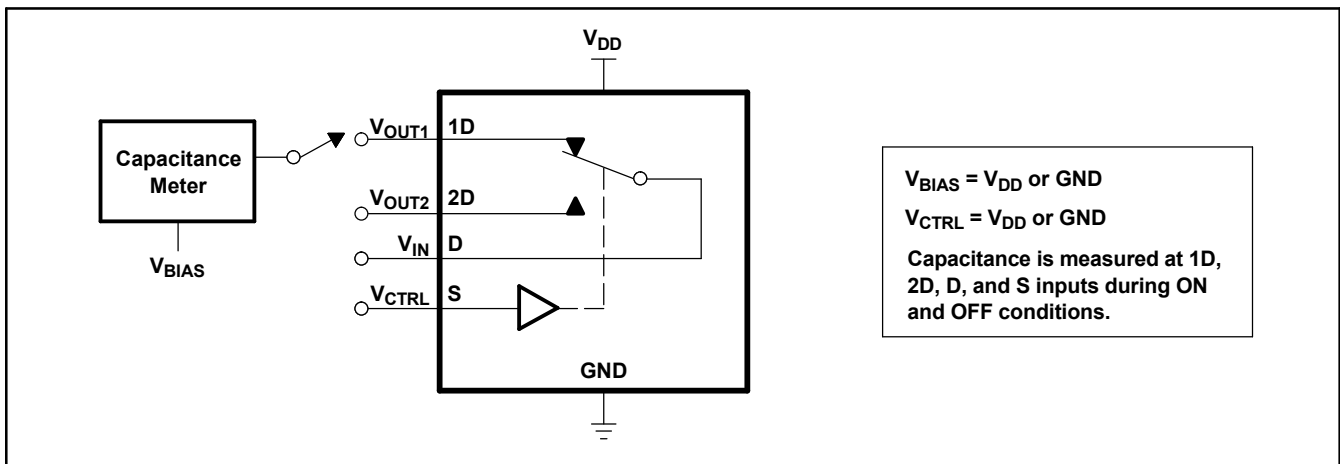
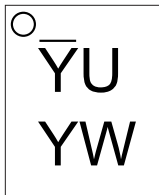

Figure 10. Capacitance

Part Marking

ZUA Package



Y : Shorten Year Code

W : Shorten Workweek Code

PI3USB221EQ

Packaging Mechanical: 10-UQFN (ZUA)

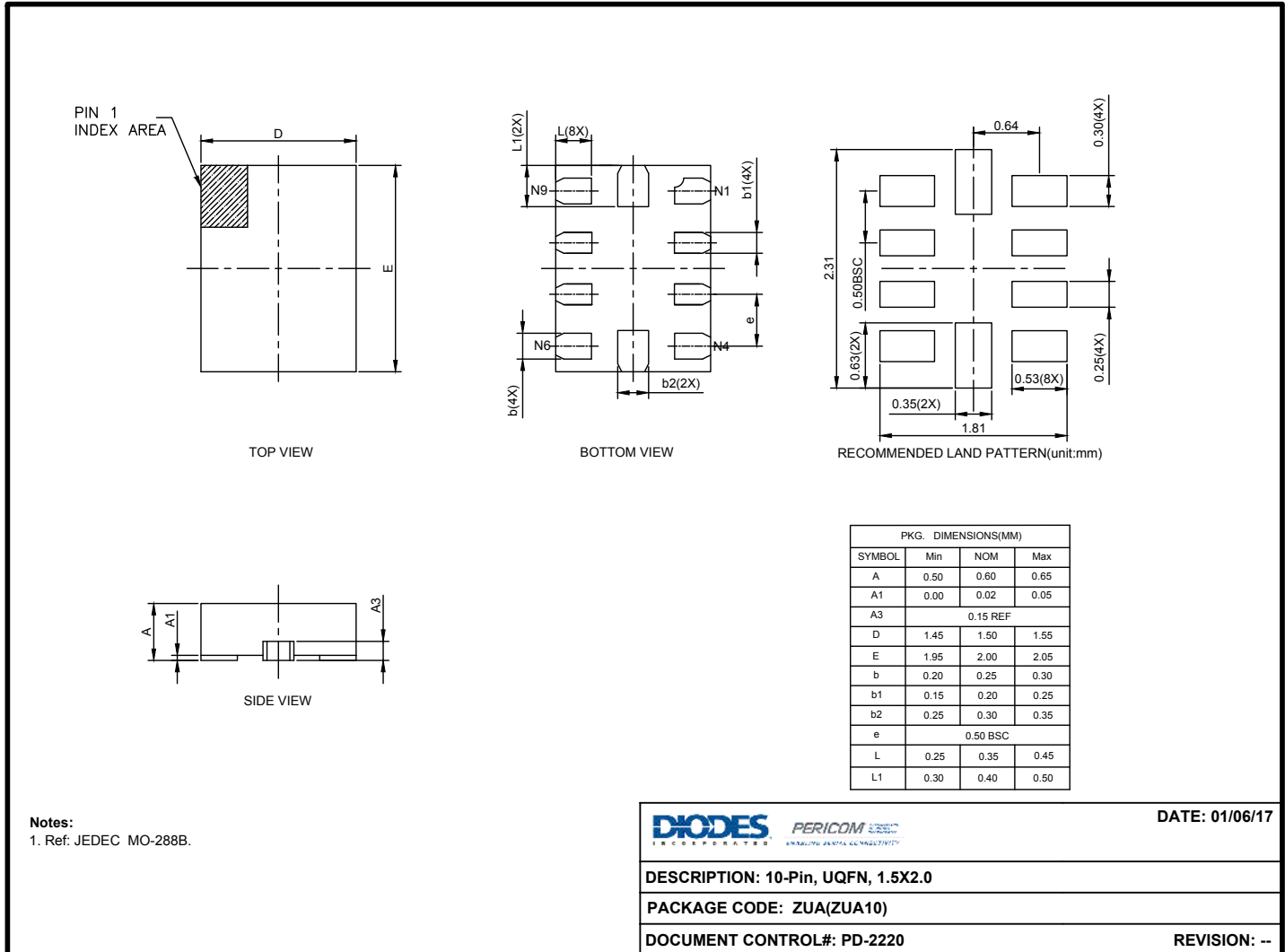

17-0002

For latest package info.

please check: <http://www.diodes.com/design/support/packaging/pericom-packaging/packaging-mechanicals-and-thermal-characteristics/>

Ordering Information

Ordering Number	Package Code	Package Description
PI3USB221EQ1ZUAEX	ZUA	10-Pin, 1.5x2.0 (UQFN)

Notes:

1. No purposely added lead. Fully EU Directive 2002/95/EC (RoHS), 2011/65/EU (RoHS 2) & 2015/863/EU (RoHS 3) compliant.
2. See <https://www.diodes.com/quality/lead-free/> for more information about Diodes Incorporated's definitions of Halogen- and Antimony-free, "Green" and Lead-free.
3. Halogen- and Antimony-free "Green" products are defined as those which contain <900ppm bromine, <900ppm chlorine (<1500ppm total Br + Cl) and <1000ppm antimony compounds.
4. Q = Automotive Compliant
5. 1 = AEC-Q100 Grade Level
6. E = Pb-free and Green
7. X suffix = Tape/Reel

IMPORTANT NOTICE

DIODES INCORPORATED MAKES NO WARRANTY OF ANY KIND, EXPRESS OR IMPLIED, WITH REGARDS TO THIS DOCUMENT, INCLUDING, BUT NOT LIMITED TO, THE IMPLIED WARRANTIES OF MERCHANTABILITY AND FITNESS FOR A PARTICULAR PURPOSE (AND THEIR EQUIVALENTS UNDER THE LAWS OF ANY JURISDICTION).

Diodes Incorporated and its subsidiaries reserve the right to make modifications, enhancements, improvements, corrections or other changes without further notice to this document and any product described herein. Diodes Incorporated does not assume any liability arising out of the application or use of this document or any product described herein; neither does Diodes Incorporated convey any license under its patent or trademark rights, nor the rights of others. Any Customer or user of this document or products described herein in such applications shall assume all risks of such use and will agree to hold Diodes Incorporated and all the companies whose products are represented on Diodes Incorporated website, harmless against all damages.

Diodes Incorporated does not warrant or accept any liability whatsoever in respect of any products purchased through unauthorized sales channel.

Should Customers purchase or use Diodes Incorporated products for any unintended or unauthorized application, Customers shall indemnify and hold Diodes Incorporated and its representatives harmless against all claims, damages, expenses, and attorney fees arising out of, directly or indirectly, any claim of personal injury or death associated with such unintended or unauthorized application.

Products described herein may be covered by one or more United States, international or foreign patents pending. Product names and markings noted herein may also be covered by one or more United States, international or foreign trademarks.

This document is written in English but may be translated into multiple languages for reference. Only the English version of this document is the final and definitive format released by Diodes Incorporated.

LIFE SUPPORT

Diodes Incorporated products are specifically not authorized for use as critical components in life support devices or systems without the express written approval of the Chief Executive Officer of Diodes Incorporated. As used herein:

A. Life support devices or systems are devices or systems which:

1. are intended to implant into the body, or
 2. support or sustain life and whose failure to perform when properly used in accordance with instructions for use provided in the labeling can be reasonably expected to result in significant injury to the user.
- B. A critical component is any component in a life support device or system whose failure to perform can be reasonably expected to cause the failure of the life support device or to affect its safety or effectiveness.

Customers represent that they have all necessary expertise in the safety and regulatory ramifications of their life support devices or systems, and acknowledge and agree that they are solely responsible for all legal, regulatory and safety-related requirements concerning their products and any use of Diodes Incorporated products in such safety-critical, life support devices or systems, notwithstanding any devices- or systems-related information or support that may be provided by Diodes Incorporated. Further, Customers must fully indemnify Diodes Incorporated and its representatives against any damages arising out of the use of Diodes Incorporated products in such safety-critical, life support devices or systems.

Copyright © 2016, Diodes Incorporated
www.diodes.com