

Evaluation Board for the **AD5243** Digital Potentiometer

FEATURES

- Full-featured evaluation board for the **AD5243**
- Various test circuits
- Various ac/dc input signals
- PC control via a separately purchased system demonstration platform (SDP-B)
- PC software for control

PACKAGE CONTENTS

- EVAL-AD5243SDZ
- CD that includes

- Self-installing software that allows users to control the board and exercise all functions of the device
- Electronic version of the **AD5243** data sheet
- Electronic version of the **UG-346** user guide

GENERAL DESCRIPTION

This user guide describes the evaluation board for evaluating the **AD5243**, a dual-channel, 256-position digital potentiometer.

The **AD5243** supports single-supply 2.7 V to 5.5 V operation, making the device suited for battery-powered applications and many other applications.

In addition, the **AD5243** uses a versatile I²C serial interface that operates in fast mode, allowing speeds of up to 400 kbps.

The EVAL-AD5243SDZ can operate in single-supply mode and incorporates an internal power supply from the USB.

Complete specifications for the **AD5243** part are in the **AD5243** data sheet, which is available from Analog Devices, Inc., and should be consulted in conjunction with this user guide when using the evaluation board.

DIGITAL PICTURE OF EVALUATION BOARD WITH SYSTEM DEMONSTRATION PLATFORM

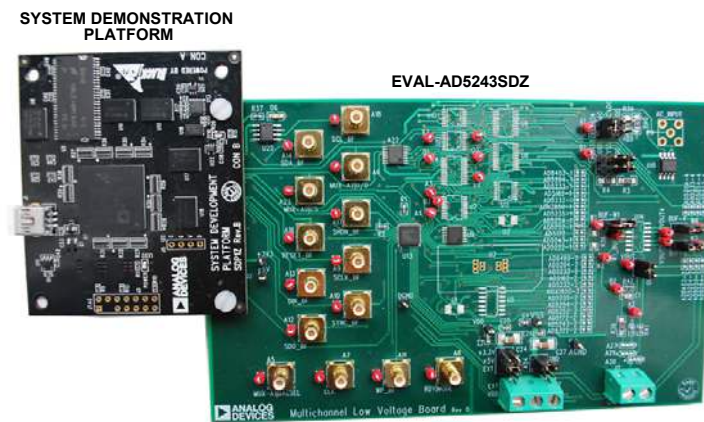

Figure 1.

TABLE OF CONTENTS

Features	1	Test Circuits	4
Package Contents.....	1	Evaluation Board Software.....	6
General Description	1	Installing the Software	6
Digital Picture of Evaluation Board with System Demonstration Platform.....	1	Running the Software	6
Revision History	2	Software Operation	7
Evaluation Board Hardware	3	Evaluation Board Schematics and Artwork.....	8
Power Supplies	3	Ordering Information.....	14
Link Options	3	Bill of Materials.....	14
		Related Links.....	15

REVISION HISTORY

12/11—Revision 0: Initial Version

EVALUATION BOARD HARDWARE

POWER SUPPLIES

The EVAL-AD5243SDZ supports using single power supplies.

The evaluation board can be powered either from the SDP-B port or externally by the J1-1 and J1-2 connectors, as described in Table 1.

All supplies are decoupled to ground using 10 μ F tantalum and 0.1 μ F ceramic capacitors.

Table 1. Maximum and Minimum Voltages of the Connectors

Connector No.	Label	Voltage
J1-1	EXT	Analog positive power supply, V_{DD} .
	VDD	For single-supply operation, the voltage is 2.7 V to 5 V.
J1-2	GND	Analog ground.

LINK OPTIONS

Several link and switch options are incorporated in the evaluation board and should be set up before using the board. Table 2 describes the positions of the links to control the evaluation board by a PC, via the SDP-B board, using the EVAL-AD5243SDZ in single-supply mode. The functions of these link options are described in detail in Table 3 through Table 6.

Table 2. Link Options Setup for SDP-B Control (Default)

Link No.	Option
A25	3.3 V
A24	GND

Table 3. Link Functions

Link No.	Power Supply	Options
A25	V_{DD}	This link selects one of the following as the positive power supply: 5 V (from SDP-B). 3.3 V (from SDP-B). EXT (external supply from the J1-1 connector).
A24	V_{SS}	This link should be connected to GND (analog ground).

TEST CIRCUITS

The EVAL-AD5243SDZ incorporates several test circuits to evaluate the AD5243 performance.

DAC

RDAC1 can be operated as a digital-to-analog converter (DAC), as shown in Figure 2.

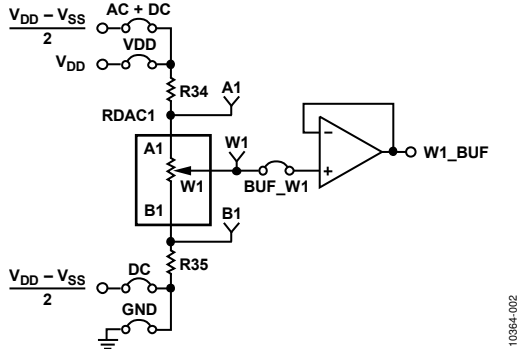

Figure 2. DAC

Table 4 shows the options available for the voltage references.

Table 4. DAC Voltage References

Terminal	Link	Options	Description
A1	A20	AC + DC	Connects Terminal A1 to $(V_{DD} - V_{SS})/2$
		VDD	Connects Terminal A1 to V_{DD}
W1	BUF_W1		Connects Terminal W1 to an output buffer
B1	A21	DC	Connects Terminal B1 to $(V_{DD} - V_{SS})/2$
		GND	Connects Terminal B1 to analog ground

The output voltage is defined in Equation 1.

$$V_{OUT} = (V_{A1} - V_{B1}) \times \frac{R_{WB1}}{256} \tag{1}$$

where:

- R_{WB1} is the resistor between the W1 and B1 terminals.
- V_{A1} is the voltage applied to the A1 terminal (A20 link).
- V_{B1} is the voltage applied to the B1 terminal (A21 link).

However, by using the R34 and R35 external resistors, the user can reduce the voltage of the voltage references. In this case, use the A1 and B1 test points to measure the voltage applied to the A0 and B0 terminals and then recalculate V_{A0} and V_{B0} in Equation 1.

AC Signal Attenuation

RDAC1 can be used to attenuate an ac signal, which must be provided externally using the AC_INPUT connector, as shown in Figure 3.

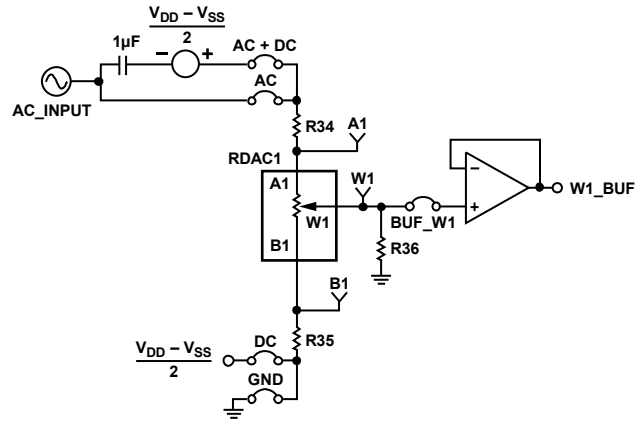

Figure 3. AC Signal Attenuator

Depending on the voltage supply rails and the dc offset voltage of the ac signal, various configurations can be used as described in Table 5.

Table 5. AC Signal Attenuation Link Options

Link	Options	Conditions
A20	AC + DC	No dc offset voltage. AC signal is outside the voltage supply rails due to the dc offset voltage. DC offset voltage $\neq V_{DD}/2$. ¹
	AC	All other conditions.
A21	DC	Use in conjunction with ac + dc link.
	GND	All other conditions.

¹ Recommended to ensure optimal total harmonic distortion (THD) performance.

The signal attenuation is defined in Equation 2.

$$Attenuation \text{ (dB)} = 20 \times \log \left(\frac{R_{WB1} + R_W}{R_{END-TO-END}} \right) \tag{2}$$

where:

- R_{WB1} is the resistor between the W1 and B1 terminals.
- R_W is the wiper resistance.
- $R_{END-TO-END}$ is the end-to-end resistance value.

In addition, R36 can be used to achieve a pseudologarithmic attenuation. To do so, adjust the R36 resistor until a desirable transfer function is found.

Signal Amplifier

RDAC2 can be operated as an inverting or noninverting signal amplifier supporting linear or pseudologarithmic gains. Table 6 shows the available configurations.

The noninverting amplifier with linear gain is shown in Figure 4, and the gain is defined in Equation 3.

$$G = 1 + \frac{R_{WB2}}{R38} \tag{3}$$

where R_{WB2} is the resistor between the W2 and B2 terminals.

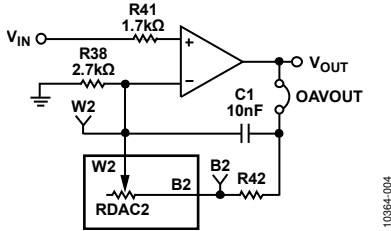

Figure 4. Linear Noninverting Amplifier

The noninverting amplifier with pseudologarithmic gain is shown in Figure 5, and the gain is defined in Equation 4.

$$G = 1 + \frac{R_{WB2}}{R_{AW2}} \tag{4}$$

where:

R_{WB2} is the resistor between the W2 and B2 terminals.

R_{AW2} is the resistor between the A2 and W2 terminals.

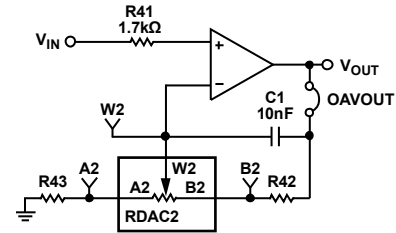

Figure 5. Pseudologarithmic Noninverting Amplifier

R43 and R42 can be used to set the maximum and minimum gain limits.

The inverting amplifier with linear gain is shown in Figure 6, and the gain is defined in Equation 5.

Note that the input signal, V_{IN} , must be negative.

$$G = -\frac{R_{WB2}}{R38} \tag{5}$$

where R_{WB2} is the resistor between the W2 and B2 terminals.

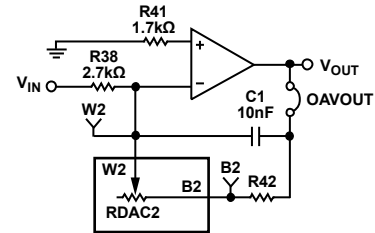

Figure 6. Linear Inverting Amplifier

Table 6. Amplifier Selection Link Options

Amplifier	Gain	Link	Label	V _{IN} Range
Noninverting	Linear	A27	LINEAR	0 V to V _{DD}
		A29	NON-INV	
		A30	NON-INV	
Noninverting	Pseudologarithmic	A27	PSEUDOLOG	0 V to V _{DD}
		A29	NON-INV	
		A30	NON-INV	
Inverting	Linear	A27	LINEAR	-V _{DD} to 0 V
		A29	INV	
		A30	INV	

EVALUATION BOARD SOFTWARE

INSTALLING THE SOFTWARE

The EVAL-AD5243SDZ evaluation kit includes evaluation board software provided on a CD. The software is compatible with Windows® XP, Windows Vista, and Windows 7 (both 32 bits and 64 bits).

Install the software before connecting the [SDP-B board](#) to the USB port of the PC to ensure that the SDP-B board is recognized when it is connected to the PC.

1. Start the Windows operating system and insert the CD.
2. The installation software opens automatically. If it does not, run the **setup.exe** file from the CD.
3. After installation is completed, power up the evaluation board as described in the Power Supplies section.
4. Connect the EVAL-AD5243SDZ into the SDP-B board and the SDP-B board into the PC using the USB cable included in the evaluation kit.
5. When the software detects the evaluation board, follow the instructions that appear to finalize the installation.

RUNNING THE SOFTWARE

To run the program, do the following:

1. Click **Start > All Programs > Analog Devices > AD5243 > AD5243 Eval Board**. To uninstall the program, click **Start > Control Panel > Add or Remove Programs > AD5243 Eval Board**.
2. If the SDP-B board is not connected to the USB port when the software is launched, a connectivity error displays (see Figure 7). Simply connect the evaluation board to the USB port of the PC, wait a few seconds, click **Rescan**, and follow the instructions.

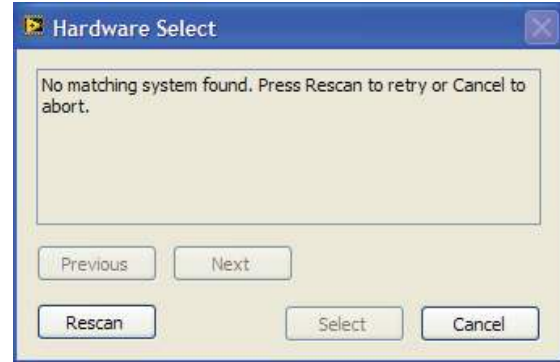

Figure 7. Pop-Up Window Error

The main window of the EVAL-AD5243SDZ evaluation software then opens, as shown in Figure 8.

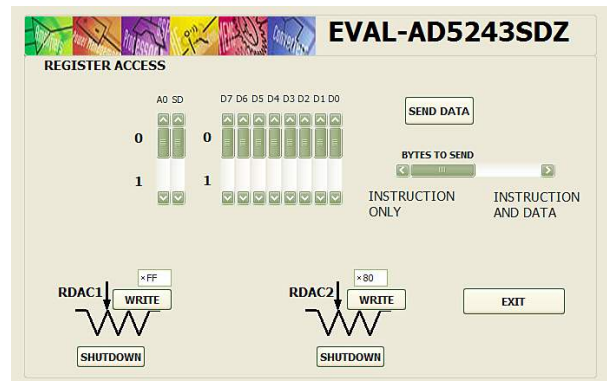

Figure 8. EVAL-AD5243SDZ Evaluation Board Software Main Window

SOFTWARE OPERATION

The main window of the EVAL-AD5243SDZ software is divided into the following sections: **RDAC1**, **RDAC2**, and **REGISTER ACCESS**.

RDAC1 and **RDAC2** can be used to update the RDAC registers by entering a desirable value into the text box and clicking **WRITE**. Additionally, clicking **SHUTDOWN** allows placing the RDAC in shutdown mode. When the button is clicked, the bit toggles automatically.

REGISTER ACCESS has the following options:

- **SEND DATA** is a customized I²C data-word that can be sent by manually switching the scroll bars from 0 to 1 or from 1 to 0, as desired, and then clicking **SEND DATA**. The command can contain one or two bytes, selected by **BYTES TO SEND**. In addition, the scroll bars are updated on each write transfer, showing the command sent to the part.
- Clicking **EXIT** closes the program but does not reset the part.

EVALUATION BOARD SCHEMATICS AND ARTWORK

10964-011

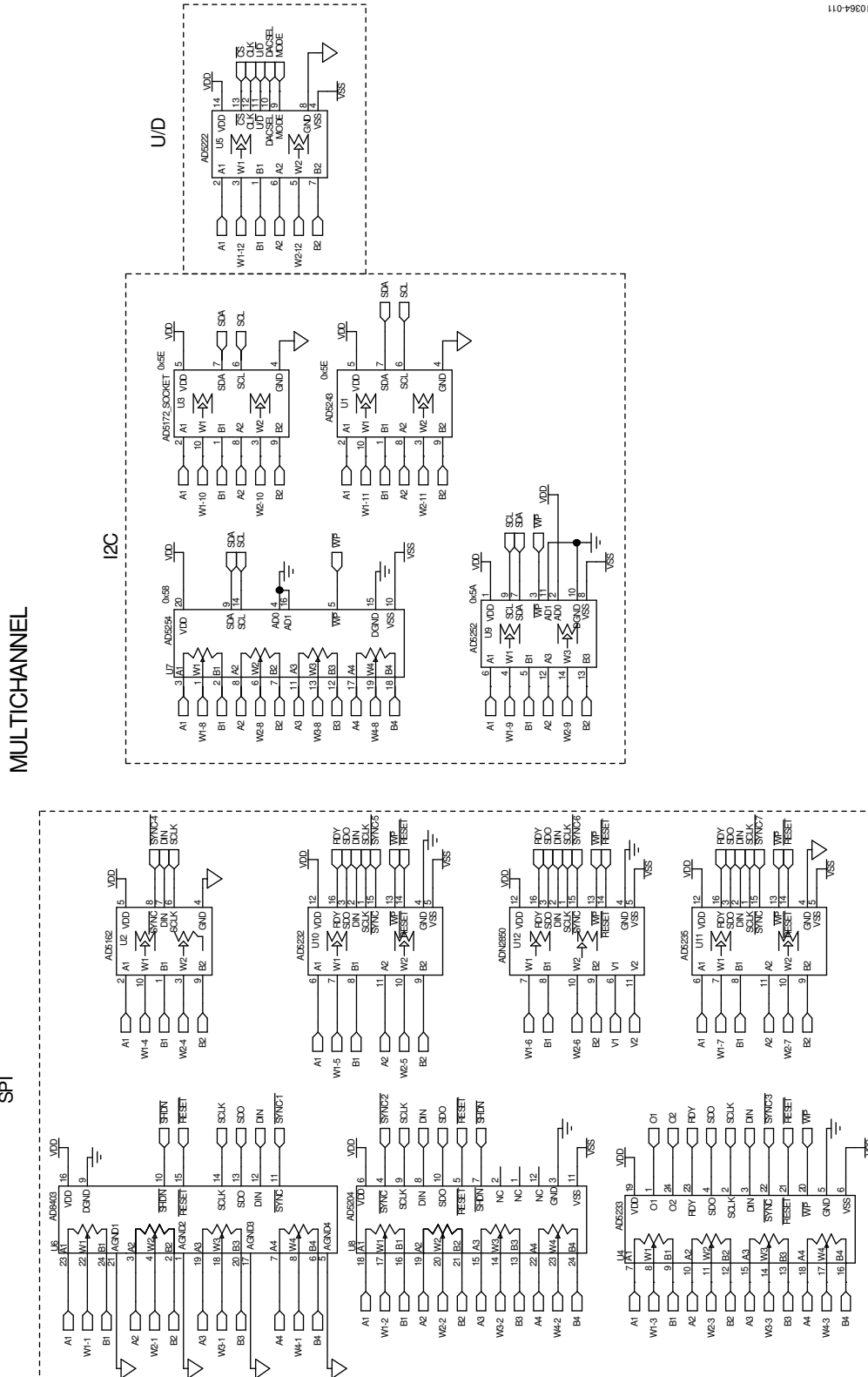

Figure 9. Schematic of Multiboard Digital Potentiometers

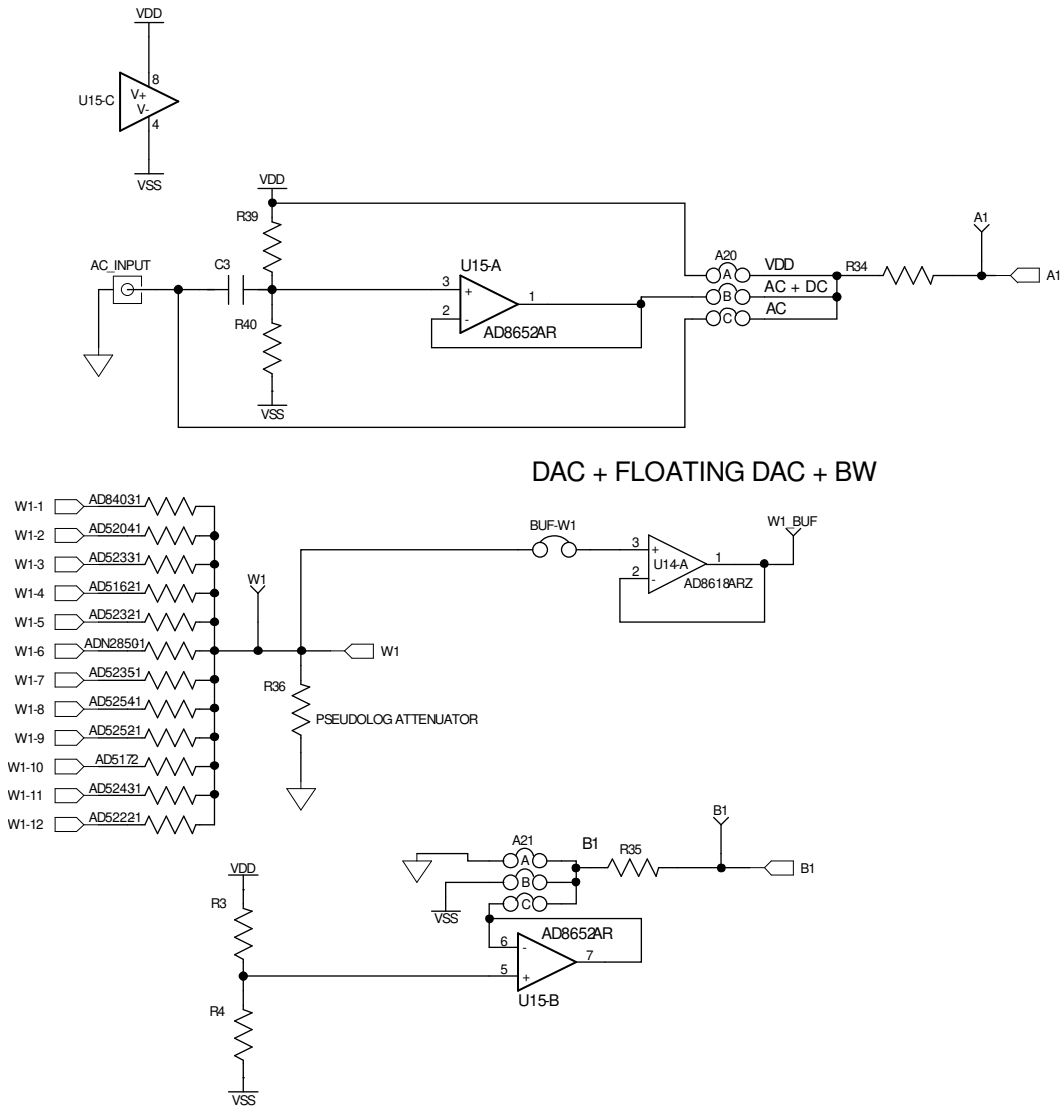

Figure 10. Schematic of Multiboard RDAC0 Circuits

INVERTING AND NON-INVERTING WITH LINEAR AND PSEUDO-LOG GAIN

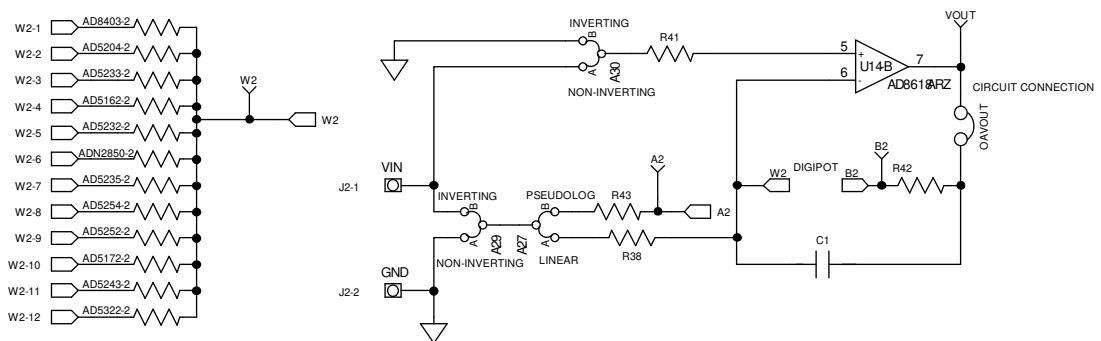
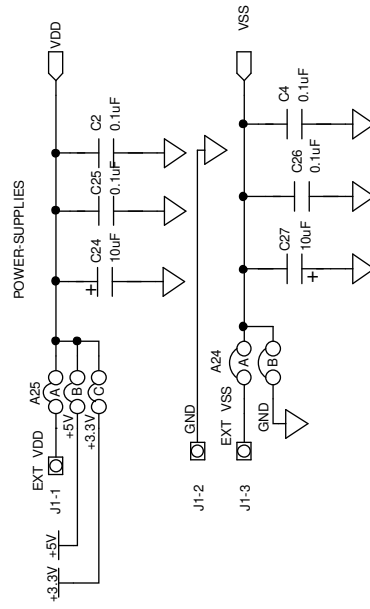
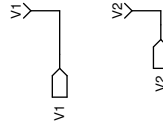

Figure 11. Schematic of Multiboard RDAC1 Circuits

POWER-SUPPLY



CURRENT MONITOR



DIGITAL PINS

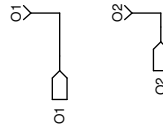

CHANNELS 3 AND 4

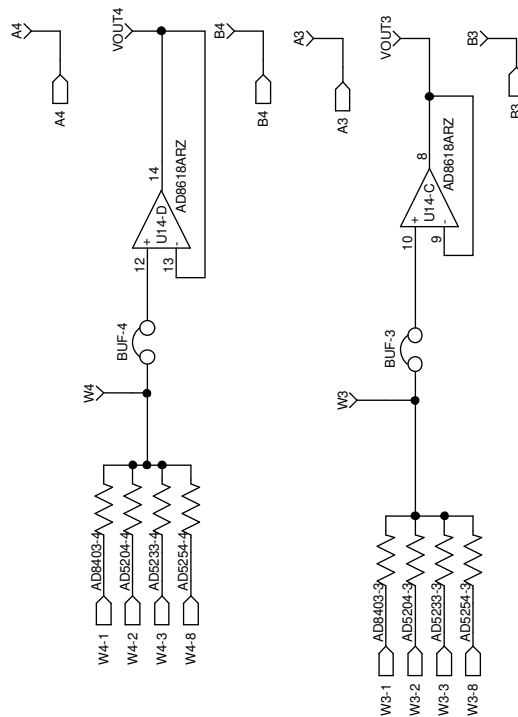

Figure 12. Schematic of AD5243 Power Supplies and Other Channels

10964-014

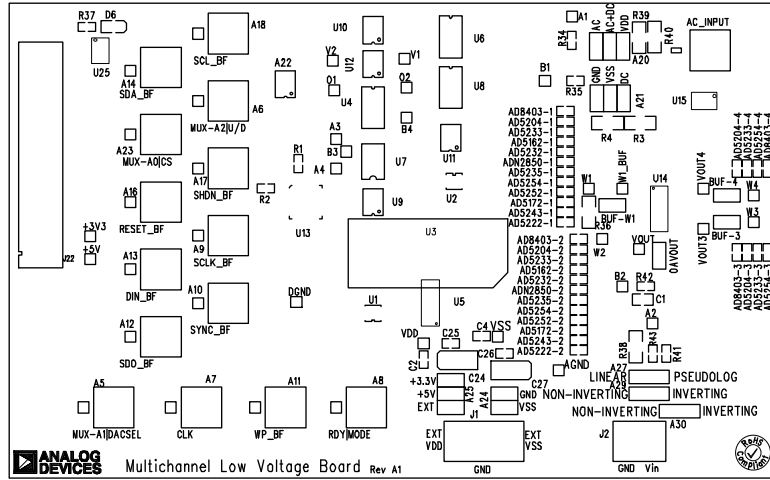

Figure 14. Component Side View

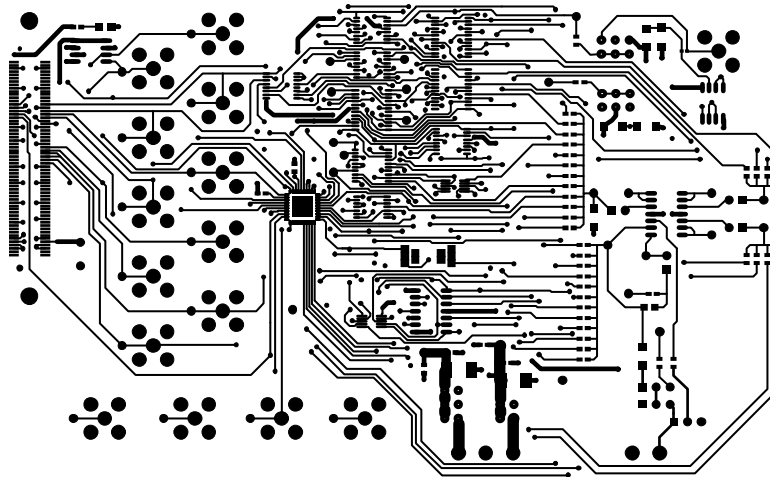

Figure 15. Component Placement Drawing

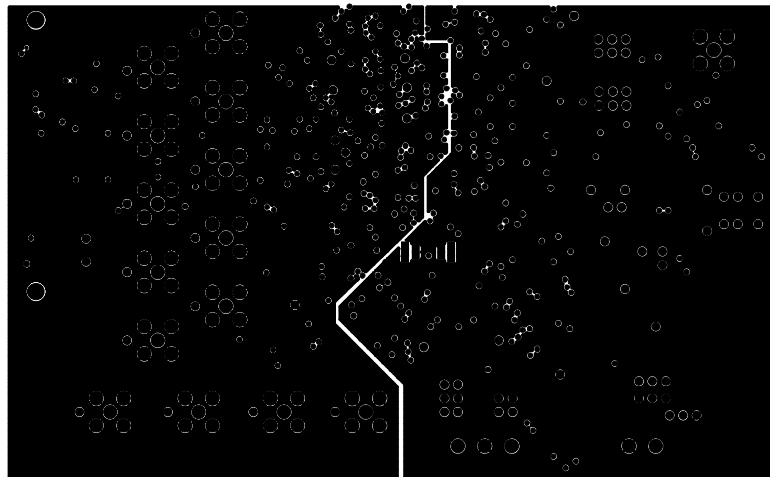

Figure 16. Layer 2 Side PCB Drawing

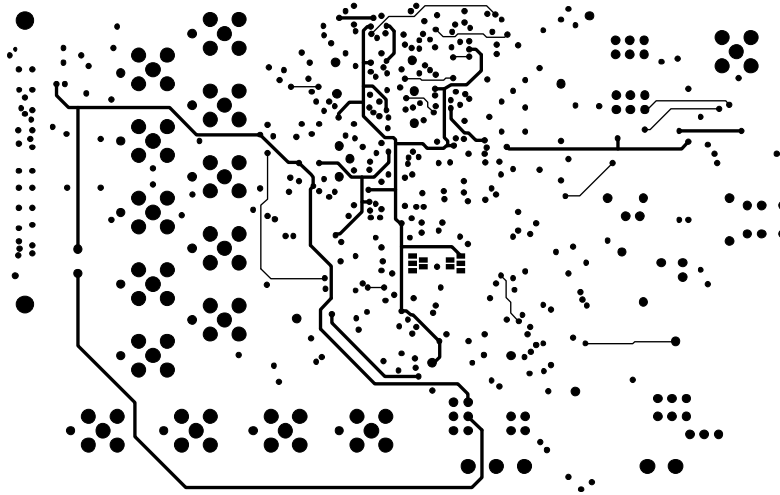

Figure 17. Layer 3 Side PCB Drawing

10384-019

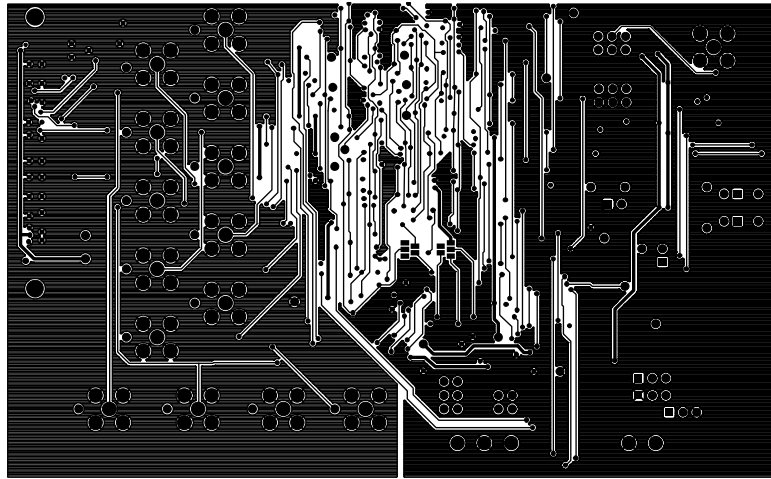

Figure 18. Solder Side PCB Drawing

10384-020

ORDERING INFORMATION

BILL OF MATERIALS

Table 7.

Qty	Reference Designator	Description	Supplier ¹ /Part Number
1	C1	10 nF capacitor, 0805	FEC 1692285
4	C2, C4, C25, C26	0.1 μ F capacitor, 0603	FEC 138-2224
1	C3	1 μ F capacitor, 0402	FEC 1288253
2	C24, C27	10 μ F capacitor, 1206	FEC 1611967
1	D6	LED, green	FEC 579-0852
1	J1	3-pin connector	FEC 151790
1	J2	2-pin connector	FEC 151789
1	J22	Receptacle, 0.6 mm, 120-way	Digi-Key H1219-ND
4	A20, A21, A24, A25	Header 2-row, 36 + 36 way and jumper socket, black	FEC 148-535 and FEC 150-410
3	A27, A29, A30	Header 1-row, 3-way and jumper socket, black	FEC 102-2248 and FEC 150-410
4	BUF-W1, OAVOUT, BUF-3, BUF-4	Header 1-row, 2-way and jumper socket, black	FEC 102-2247 and FEC 150-410
1	R41	1.78 k Ω resistor, 0603, 1%	FEC 1170811
2	R1, R2	2.2 k Ω resistor, 0603, 1%	FEC 933-0810
5	R3, R4, R38, R39, R40	2.7 k Ω resistor, 1206, 1%	FEC 9337288
36	AD5162-1, AD5162-2, AD5243-1, AD5243-2, AD5204-1, AD5204-2, AD5204-3, AD5204-4, AD5222-1, AD5222-2, AD5232-1, AD5232-2, AD5233-1, AD5233-2, AD5233-3, AD5233-4, AD5235-1, AD5235-2, AD5243-1, AD5243-2, AD5252-1, AD5252-2, AD5243-1, AD5243-2, AD5243-3, AD5243-4, AD5243-1, AD5243-2, AD5243-3, AD5243-4, ADN2850-1, ADN2850-2, R34, R35, R42, R43	0 Ω resistor, 0603	FEC 9331662
1	R37	1 k Ω resistor, 0603, 1%	FEC 933-0380
6	3.3 V, 5 V, DGND, AGND, VDD, VSS	Test point, PCB, black, PK100	FEC 873-1128
34	A1, A2, A3, A4, RDY MODE, RESET_BF, SCL_BF, SCLK_BF, SDA_BF, SDO_BF, SHDN_BF, SYNC_BF, MUX-A0 CS, MUX-A1 DACSEL MUX-A2 U/D, O1, O2, DIN_BF, CLK, B1, B2, B3, B4, V1, V2, VOUT, VOUT2, VOUT3, VOUT4, W1, W1_BUF, W2, W3, W4, WP_BUF	Test point, PCB, red, PK100	FEC 873-1144
1	U1	256-position, dual-channel, I ² C-compatible digital potentiometer	Analog Devices AD5243
1	U2	256-position, dual-channel, SPI digital potentiometer	Analog Devices AD5162
1	U3	256-position, one-time programmable, dual-channel, I ² C digital potentiometer	Analog Devices AD5243
1	U4	Nonvolatile, quad, 64-position digital potentiometer	Analog Devices AD5233
1	U5	Dual, increment/decrement digital potentiometer	Analog Devices AD5222
1	U6	4-channel digital potentiometer	Analog Devices AD5243
1	U7	Quad, 256-position, I ² C, nonvolatile memory digital potentiometer	Analog Devices AD5254
1	U8	4-channel digital potentiometer	Analog Devices AD5204
1	U9	I ² C, nonvolatile memory, dual, 256-position digital potentiometer	Analog Devices AD5252
1	U10	Nonvolatile memory, dual, 256-position digital potentiometer	Analog Devices AD5232
1	U11	Dual, 1024-position digital potentiometer with nonvolatile memory and SPI interface	Analog Devices AD5235

Qty	Reference Designator	Description	Supplier ¹ /Part Number
1	U12	Dual, 1024-position digital rheostat with nonvolatile memory and SPI interface	Analog Devices ADN2850
1	U13	2.5 V/3.3 V, 16-bit (dual 8-bit), 2-port level translator bus switch	Analog Devices ADG3247
1	A22	3 V/5 V, ± 5 V CMOS, 8-channel analog multiplexer	Analog Devices ADG658
1	U15	50 MHz, precision, low distortion, low noise CMOS amplifier	Analog Devices AD8652
1	U14	Precision, 20 MHz, CMOS, quad, rail-to-rail operational amplifier	Analog Devices AD8618
1	U25	24LC64 EEPROM	FEC 975-8070

¹ FEC refers to Farnell Electronic Component Distributors; Digi-Key refers to Digi-Key Corporation.

RELATED LINKS

Resource	Description
AD5243	Product Page, 256-Position Dual-Channel I ² C Compatible Digital Potentiometer
AD5162	Product Page, 256-Position Dual-Channel SPI Digital Potentiometer
AD5233	Product Page, Nonvolatile, Quad, 64-Position Digital Potentiometer
AD5222	Product Page, Dual, Increment/Decrement Digital Potentiometer
AD5243	Product Page, 4-Channel Digital Potentiometer
AD5254	Product Page, Quad 256-Position I ² C Nonvolatile Memory, Digital Potentiometer
AD5204	Product Page, 4-Channel Digital Potentiometer
AD5252	Product Page, I ² C, Nonvolatile Memory, Dual, 256-Position Digital Potentiometer
AD5232	Product Page, Nonvolatile Memory, Dual, 256-Position Digital Potentiometer
AD5235	Product Page, Dual 1024-Position Digital Potentiometer with Nonvolatile Memory and SPI Interface
ADN2850	Product Page, Dual 1024-Position Digital Rheostat with Nonvolatile Memory and SPI Interface
ADG3247	Product Page, 2.5 V/3.3 V, 16-Bit (Dual 8-Bit), 2-Port Level Translator, Bus Switch
ADG658	Product Page, 3 V/5 V ± 5 V CMOS 8-Channel Analog Multiplexer
AD8652	Product Page, 50 MHz, Precision, Low Distortion, Low Noise CMOS Amplifier
AD8618	Product Page, Precision 20 MHz CMOS Quad Rail-to-Rail Operational Amplifier

NOTES

I²C refers to a communications protocol originally developed by Philips Semiconductors (now NXP Semiconductors).

**ESD Caution**

ESD (electrostatic discharge) sensitive device. Charged devices and circuit boards can discharge without detection. Although this product features patented or proprietary protection circuitry, damage may occur on devices subjected to high energy ESD. Therefore, proper ESD precautions should be taken to avoid performance degradation or loss of functionality.

Legal Terms and Conditions

By using the evaluation board discussed herein (together with any tools, components documentation or support materials, the "Evaluation Board"), you are agreeing to be bound by the terms and conditions set forth below ("Agreement") unless you have purchased the Evaluation Board, in which case the Analog Devices Standard Terms and Conditions of Sale shall govern. Do not use the Evaluation Board until you have read and agreed to the Agreement. Your use of the Evaluation Board shall signify your acceptance of the Agreement. This Agreement is made by and between you ("Customer") and Analog Devices, Inc. ("ADI"), with its principal place of business at One Technology Way, Norwood, MA 02062, USA. Subject to the terms and conditions of the Agreement, ADI hereby grants to Customer a free, limited, personal, temporary, non-exclusive, non-sublicensable, non-transferable license to use the Evaluation Board FOR EVALUATION PURPOSES ONLY. Customer understands and agrees that the Evaluation Board is provided for the sole and exclusive purpose referenced above, and agrees not to use the Evaluation Board for any other purpose. Furthermore, the license granted is expressly made subject to the following additional limitations: Customer shall not (i) rent, lease, display, sell, transfer, assign, sublicense, or distribute the Evaluation Board; and (ii) permit any Third Party to access the Evaluation Board. As used herein, the term "Third Party" includes any entity other than ADI, Customer, their employees, affiliates and in-house consultants. The Evaluation Board is NOT sold to Customer; all rights not expressly granted herein, including ownership of the Evaluation Board, are reserved by ADI. CONFIDENTIALITY. This Agreement and the Evaluation Board shall all be considered the confidential and proprietary information of ADI. Customer may not disclose or transfer any portion of the Evaluation Board to any other party for any reason. Upon discontinuation of use of the Evaluation Board or termination of this Agreement, Customer agrees to promptly return the Evaluation Board to ADI. ADDITIONAL RESTRICTIONS. Customer may not disassemble, decompile or reverse engineer chips on the Evaluation Board. Customer shall inform ADI of any occurred damages or any modifications or alterations it makes to the Evaluation Board, including but not limited to soldering or any other activity that affects the material content of the Evaluation Board. Modifications to the Evaluation Board must comply with applicable law, including but not limited to the RoHS Directive. TERMINATION. ADI may terminate this Agreement at any time upon giving written notice to Customer. Customer agrees to return to ADI the Evaluation Board at that time. LIMITATION OF LIABILITY. THE EVALUATION BOARD PROVIDED HEREUNDER IS PROVIDED "AS IS" AND ADI MAKES NO WARRANTIES OR REPRESENTATIONS OF ANY KIND WITH RESPECT TO IT. ADI SPECIFICALLY DISCLAIMS ANY REPRESENTATIONS, ENDORSEMENTS, GUARANTEES, OR WARRANTIES, EXPRESS OR IMPLIED, RELATED TO THE EVALUATION BOARD INCLUDING, BUT NOT LIMITED TO, THE IMPLIED WARRANTY OF MERCHANTABILITY, TITLE, FITNESS FOR A PARTICULAR PURPOSE OR NON-INFRINGEMENT OF INTELLECTUAL PROPERTY RIGHTS. IN NO EVENT WILL ADI AND ITS LICENSORS BE LIABLE FOR ANY INCIDENTAL, SPECIAL, INDIRECT, OR CONSEQUENTIAL DAMAGES RESULTING FROM CUSTOMER'S POSSESSION OR USE OF THE EVALUATION BOARD, INCLUDING BUT NOT LIMITED TO LOST PROFITS, DELAY COSTS, LABOR COSTS OR LOSS OF GOODWILL. ADI'S TOTAL LIABILITY FROM ANY AND ALL CAUSES SHALL BE LIMITED TO THE AMOUNT OF ONE HUNDRED US DOLLARS (\$100.00). EXPORT. Customer agrees that it will not directly or indirectly export the Evaluation Board to another country, and that it will comply with all applicable United States federal laws and regulations relating to exports. GOVERNING LAW. This Agreement shall be governed by and construed in accordance with the substantive laws of the Commonwealth of Massachusetts (excluding conflict of law rules). Any legal action regarding this Agreement will be heard in the state or federal courts having jurisdiction in Suffolk County, Massachusetts, and Customer hereby submits to the personal jurisdiction and venue of such courts. The United Nations Convention on Contracts for the International Sale of Goods shall not apply to this Agreement and is expressly disclaimed.