

ebn-popst MFG. NOTES

1 LEAD DIMENSION IS AT FULL EXTENSION

REV.	EC #	REVISION DESCRIPTION	DATE	D.ENG.	CHECKER
001	2887	RELEASE TO PRODUCTION	06/08/00	BARB	MZ
002	6579	CHANGE 22AWG TO 18AWG. ADD PROD.ID LABEL	09/22/04	DTM	DW
003	6579	CHANGE LEAD LENGTH TO 72" (WAS 36")	08/05/16	DTM	DTM

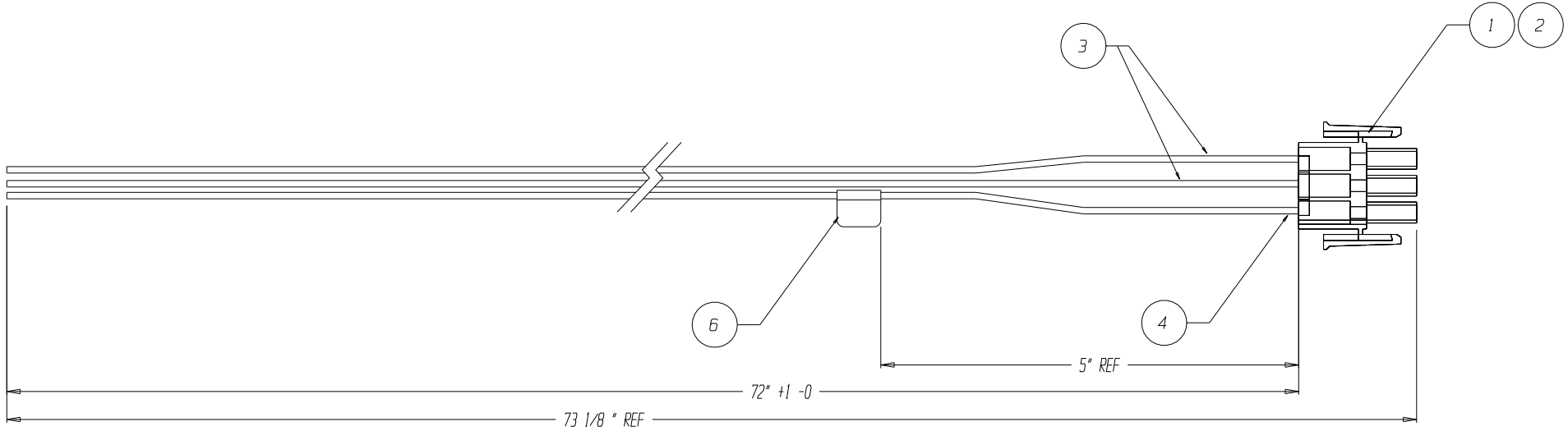

LEAD PIN CALLOUT	
PIN 1	BLACK
PIN 2	BLACK
PIN 3	GREEN/YELLOW

WIRE TIE USED TO BUNDLE WRAP

ITEM	QTY	PART NUMBER	DESCRIPTION
6	1	605-50-2660	PRODUCT ID LABEL
5	1	400-50-0003	WIRE TIE 4"
4	1	410-18-0003	GREEN/YELLOW AWG18 UL1007
3	2	410-18-0014	BLACK AWG18 UL1007
2	3	405-12-0089	AMP 350536-1 TERM (REEL)
	REF	405-12-0006	AMP 350550-1 TERM (LOOSE)
1	1	405-14-0004	AMP 350766-1 CONNECTOR

ebn-popst Inc. DISCLOSURE THIS DOCUMENT IS THE PROPERTY OF ebn-popst Inc. ITS USE IS AUTHORIZED BY ebn-popst Inc. ONLY. ALL QUESTIONS MUST BE REFERRED TO ebn-popst Inc. PERSONNEL: DESIGN ENG., MFG.ENG., AND / OR PURCHASING. CAUTION: ANY PRINTED COPY IS UNCONTROLLED AND TO BE USED FOR REFERENCE ONLY. REFER TO ebn-popst In. CAD SYS. FOR VERIFICATION. Form No. 1073 Rev. H		MATERIAL: N/A FINISH: N/A IF APPLICABLE PLACE SECOND FINISH AND DESCRIPTION HERE ALL INNER BEND RADI = 1mm BOTTOM BEND UNLESS OTHERWISE STATED TOLERANCES, UNLESS OTHERWISE STATED: DECIMAL .XXX ± .020 HOLES .XXX ± .003 TOLERANCES FOR CNC FLAT .XXX EXCLUDING HOLE DIA. +/- .010 TOLERANCE .XX ± .030 ANGLES ± 1° REF	BEND DEDUCTION N/A COSMETICS PER ebn-popst SPEC-Q-1 SEE CAD FOR DIMS. NOT SHOWN BREAK ALL SHARP EDGES ALL DIMENSIONS ARE IN INCHES 	PART NO. 420-05-0276 TITLE AC POWER CONTROL HARNESS FIRST USED ON 420-05-0276 DESIGN ENG. DTM ORG. DATE 05/01/00 E# EA-0663	
		REVISION 003	SHEET 1 OF 1		