



AMP★ ECONOMATE★ I
ZERO INSERTION FORCE (ZIF)
CONTACT REPLACEMENT TOOL
 Catalog No. 266235-1

IS 2997	
RELEASED	1-15-82
REVISED	

1. INTRODUCTION

AMP ZIF Contact Replacement Tool No. 266235-1 is used to replace individual damaged contacts on pc boards and panels without removing the ZIF connector housings.

This tool assembly (Figure 1) consists of three replaceable parts: a plastic handle, a threaded metal tip holder which screws into the handle, and a contact replacement tip which is inserted into the tip holder

and locked into position by two setscrews. If the contact replacement tip is damaged or broken at any time, it can be removed simply by loosening the two setscrews. A new tip is then inserted to the proper position (Figure 1) and the setscrews retightened. Replacement tips and/or tools can be obtained from AMP Incorporated.

Replacement of contacts through the connector housing requires removal of one or more wings from the housing. This is accomplished by the use of AMP ZIF Connector Housing Wing Removal and Replacement Tool No. 266233-1, as described in AMP Instruction Sheet IS 2995, supplied with the tool.

Following removal of wing (or wings), as required, the contacts to be replaced must be removed using AMP Pin and Contact Replacement Tool No. 265871-□, with Contact Removal Tip No. 265964-1, as described in AMP Instruction Sheet IS 2636, supplied with the tool.

2. CONTACT REPLACEMENT INSTRUCTIONS

2.1 WING REMOVAL

With ZIF cams in closed position (Figure 2), remove wing (or wings), as required for replacement of damaged contact(s). This is accomplished by using ZIF Wing Removal and Replacement Tool No. 266233-1. Carefully follow instructions given in IS 2995, supplied with the tool, to remove wings.

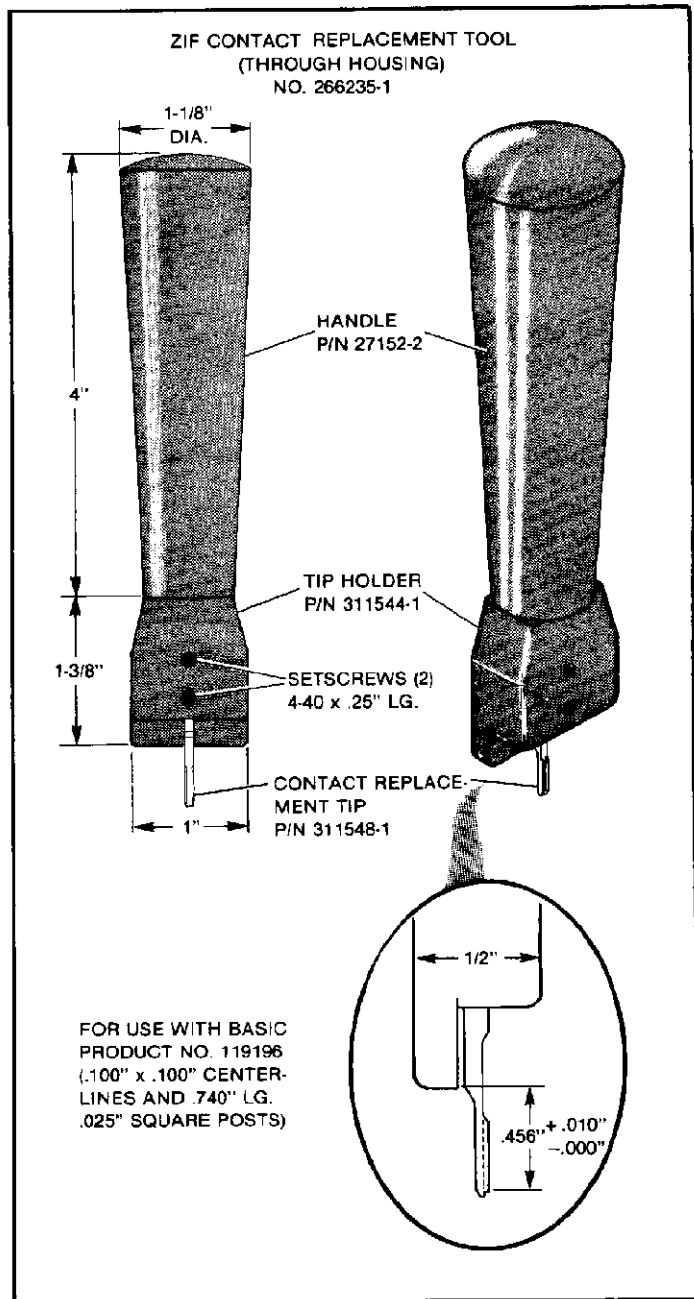

Figure 1

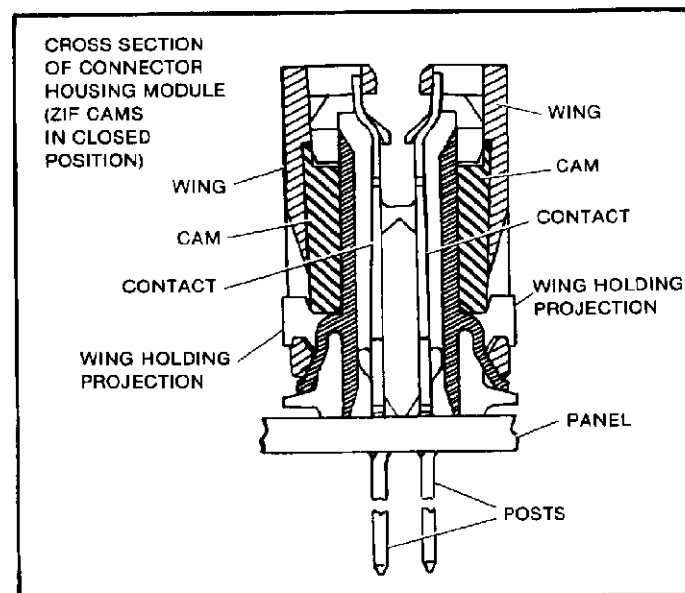

Figure 2

2.2 DAMAGED CONTACT REMOVAL

Use Pin and Contact Replacement Tool No. 265871-□, with Contact Removal Tip No. 265964-1, to remove

Copyright 1982 by AMP Incorporated, Harrisburg, Pa. All International Rights Reserved. AMP Incorporated products covered by U.S. and Foreign Patents and/or Patents Pending.

damaged contact(s). Carefully follow instructions given in IS 2636, supplied with the tool, to remove the contact(s).

NOTE: IS 2636 is included in Customer Manual CM 2642 which is provided with all AMP ACTION PIN[®] Assembly Kits.

2.3 CONTACT REPLACEMENT

NOTE: Do not re-use ACTION PIN contacts removed from pc board or panel.

- (a) Insert replacement contact, with lance facing away from center of connector, into place in connector housing and through pin hole in pc board or panel. See Figure 3.

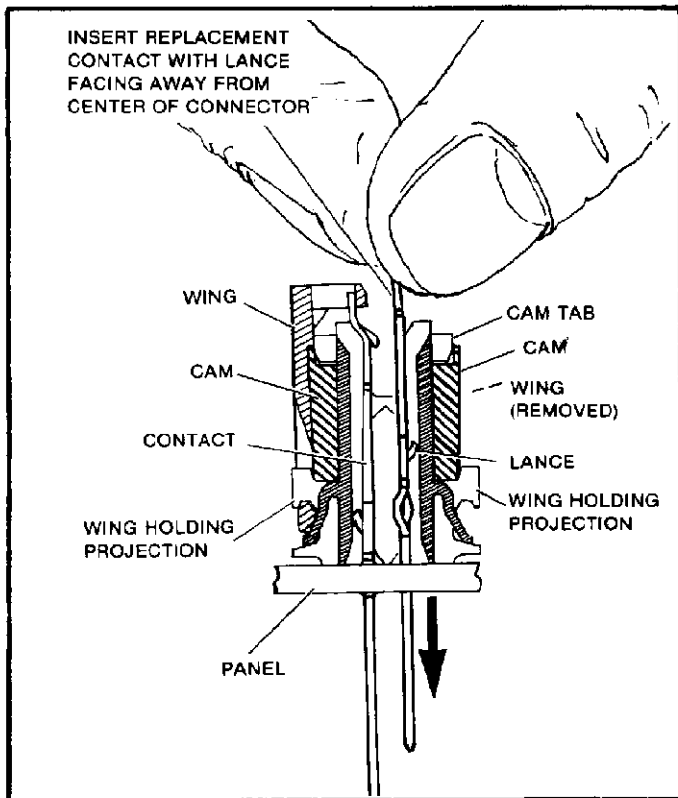

Figure 3

- (b) Place contact replacement tip of tool on lance side of contact down against push shoulder of contact and push contact down until tool bottoms on cam tab at top of housing. See Figure 4.
- (c) Repeat steps (a) and (b), as necessary, to replace all contacts that were removed.

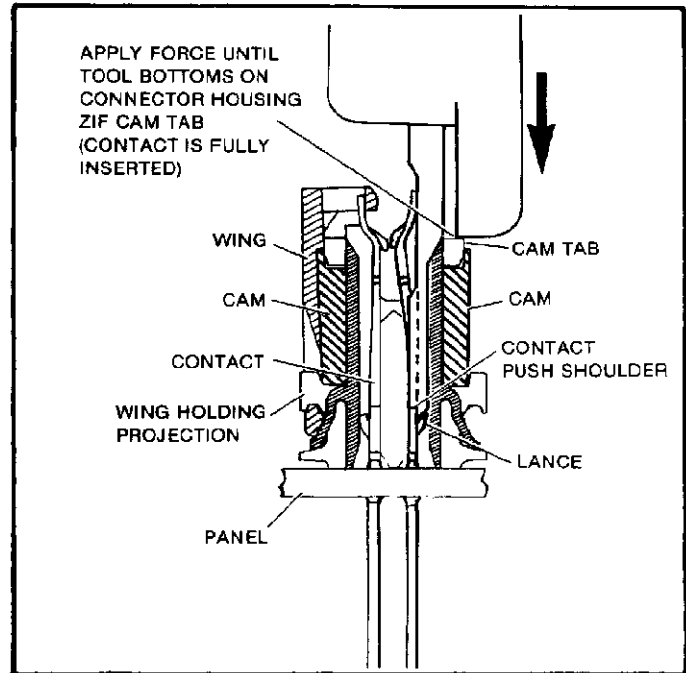

Figure 4

2.4 WING REASSEMBLY

- (a) Use the ZIF wing removal and replacement tool to reassemble wings to connector housing. Carefully follow instructions given in IS 2995, supplied with the tool, for replacing wings.
- (b) When all wings are replaced, actuate cams to check connector for proper ZIF operation.