

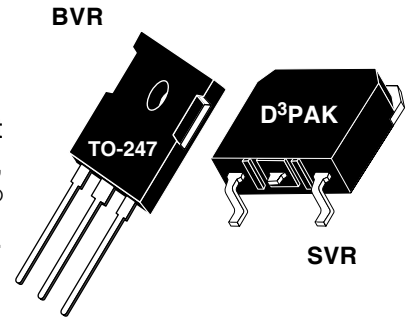

Power MOS V<sup>®</sup> is a new generation of high voltage N-Channel enhancement mode power MOSFETs. This new technology minimizes the JFET effect, increases packing density and reduces the on-resistance. Power MOS V<sup>®</sup> also achieves faster switching speeds through optimized gate layout.

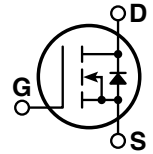

- **Faster Switching**
- **Lower Leakage**
- **TO-247 or Surface Mount D<sup>3</sup>PAK Package**
- **Avalanche Energy Rated**



### MAXIMUM RATINGS

All Ratings: T<sub>C</sub> = 25°C unless otherwise specified.

Symbol	Parameter	APT6030BVR_SVR	UNIT
V <sub>DSS</sub>	Drain-Source Voltage	600	Volts
I <sub>D</sub>	Continuous Drain Current @ T <sub>C</sub> = 25°C	21	Amps
I <sub>DM</sub>	Pulsed Drain Current <sup>①</sup>	84	
V <sub>GS</sub>	Gate-Source Voltage Continuous	±30	Volts
V <sub>GSM</sub>	Gate-Source Voltage Transient	±40	
P <sub>D</sub>	Total Power Dissipation @ T <sub>C</sub> = 25°C	298	Watts
	Linear Derating Factor	2.38	W/°C
T <sub>J</sub> , T <sub>STG</sub>	Operating and Storage Junction Temperature Range	-55 to 150	°C
T <sub>L</sub>	Lead Temperature: 0.063" from Case for 10 Sec.	300	
I <sub>AR</sub>	Avalanche Current <sup>①</sup> (Repetitive and Non-Repetitive)	21	Amps
E <sub>AR</sub>	Repetitive Avalanche Energy <sup>①</sup>	30	mJ
E <sub>AS</sub>	Single Pulse Avalanche Energy <sup>④</sup>	1300	

### STATIC ELECTRICAL CHARACTERISTICS

Symbol	Characteristic / Test Conditions	MIN	TYP	MAX	UNIT
BV <sub>DSS</sub>	Drain-Source Breakdown Voltage (V <sub>GS</sub> = 0V, I <sub>D</sub> = 250μA)	600			Volts
R <sub>DS(on)</sub>	Drain-Source On-State Resistance <sup>②</sup> (V <sub>GS</sub> = 10V, I <sub>D</sub> = 10.5A)			0.300	Ohms
I <sub>DSS</sub>	Zero Gate Voltage Drain Current (V <sub>DS</sub> = 600V, V <sub>GS</sub> = 0V)			25	μA
	Zero Gate Voltage Drain Current (V <sub>DS</sub> = 480V, V <sub>GS</sub> = 0V, T <sub>C</sub> = 125°C)			250	
I <sub>GSS</sub>	Gate-Source Leakage Current (V <sub>GS</sub> = ±30V, V <sub>DS</sub> = 0V)			±100	nA
V <sub>GS(th)</sub>	Gate Threshold Voltage (V <sub>DS</sub> = V <sub>GS</sub> , I <sub>D</sub> = 1mA)	2		4	Volts

 **CAUTION:** These Devices are Sensitive to Electrostatic Discharge. Proper Handling Procedures Should Be Followed.

### DYNAMIC CHARACTERISTICS

APT6030BVR\_SVR

Symbol	Characteristic	Test Conditions	MIN	TYP	MAX	UNIT
$C_{iss}$	Input Capacitance	$V_{GS} = 0V$ $V_{DS} = 25V$ $f = 1 \text{ MHz}$		3750		pF
$C_{oss}$	Output Capacitance			430		
$C_{rss}$	Reverse Transfer Capacitance			160		
$Q_g$	Total Gate Charge ③	$V_{GS} = 10V$ $V_{DD} = 300V$ $I_D = 21A @ 25^\circ C$		150		nC
$Q_{gs}$	Gate-Source Charge			18		
$Q_{gd}$	Gate-Drain ("Miller") Charge			60		
$t_{d(on)}$	Turn-on Delay Time	$V_{GS} = 15V$ $V_{DD} = 300V$ $I_D = 21A @ 25^\circ C$ $R_G = 1.6\Omega$		12		ns
$t_r$	Rise Time			10		
$t_{d(off)}$	Turn-off Delay Time			47		
$t_f$	Fall Time			8		

### SOURCE-DRAIN DIODE RATINGS AND CHARACTERISTICS

Symbol	Characteristic / Test Conditions	MIN	TYP	MAX	UNIT
$I_S$	Continuous Source Current (Body Diode)			21	Amps
$I_{SM}$	Pulsed Source Current ① (Body Diode)			84	
$V_{SD}$	Diode Forward Voltage ② ( $V_{GS} = 0V, I_S = -21A$ )			1.3	Volts
$t_{rr}$	Reverse Recovery Time ( $I_S = -21A, di_S/dt = 100A/\mu s$ )		475		ns
$Q_{rr}$	Reverse Recovery Charge ( $I_S = -21A, di_S/dt = 100A/\mu s$ )		10		$\mu C$
$dv/dt$	Peak Diode Recovery $dv/dt$ ⑤			8	V/ns

### THERMAL CHARACTERISTICS

Symbol	Characteristic	MIN	TYP	MAX	UNIT
$R_{\theta JC}$	Junction to Case			0.42	$^\circ C/W$
$R_{\theta JA}$	Junction to Ambient			40	

① Repetitive Rating: Pulse width limited by maximum junction temperature

② Pulse Test: Pulse width < 380  $\mu s$ , Duty Cycle < 2%

③ See MIL-STD-750 Method 3471

APT Reserves the right to change, without notice, the specifications and information contained herein.

④ Starting  $T_j = +25^\circ C$ ,  $L = 5.90mH$ ,  $R_G = 25\Omega$ , Peak  $I_L = 21A$

⑤  $dv/dt$  numbers reflect the limitations of the test circuit rather than the device itself.  $I_S \leq -I_D 21A$   $di/dt \leq 700A/\mu s$   $v_R \leq 600V$   $T_J \leq 150^\circ C$

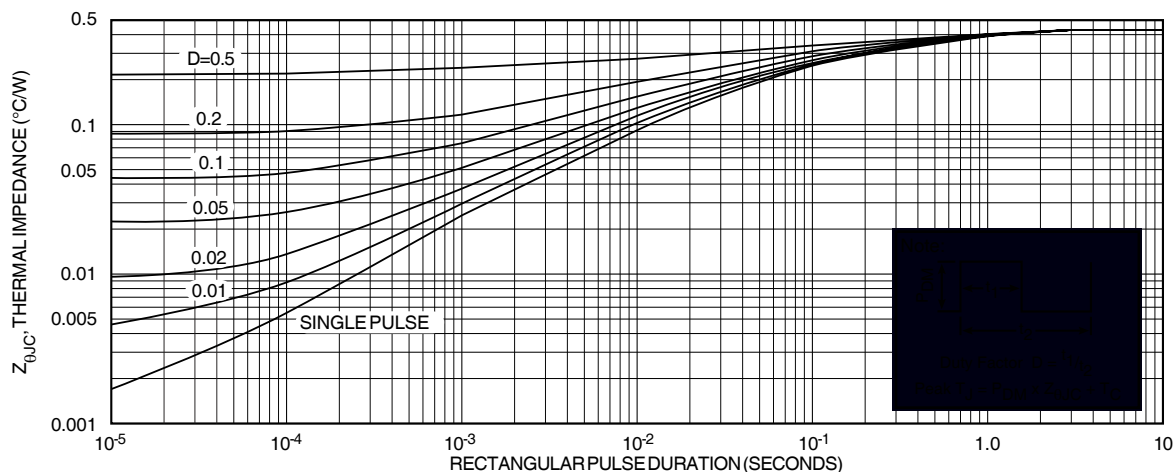

FIGURE 1, MAXIMUM EFFECTIVE TRANSIENT THERMAL IMPEDANCE, JUNCTION-TO-CASE vs PULSE DURATION

Typical Performance Curves

APT6030BVR\_SVR

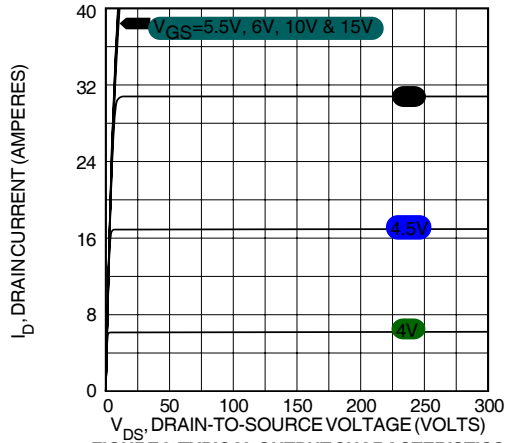

FIGURE 2, TYPICAL OUTPUT CHARACTERISTICS

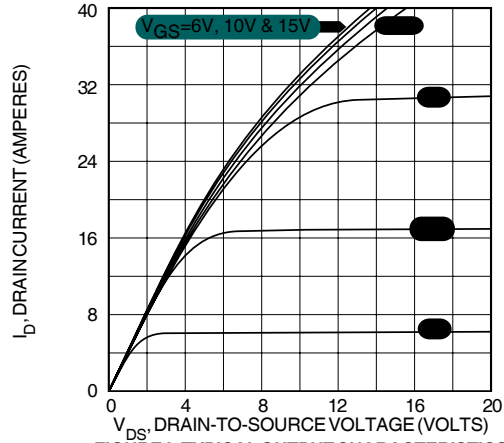

FIGURE 3, TYPICAL OUTPUT CHARACTERISTICS

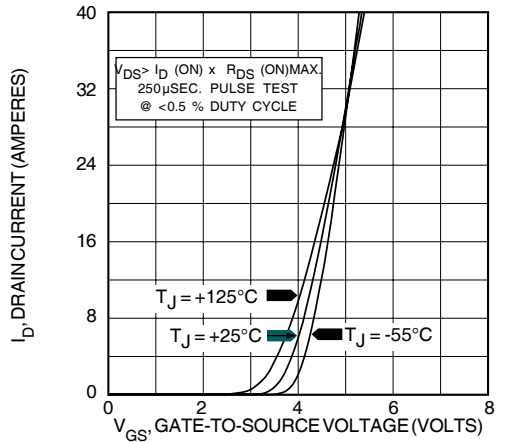

FIGURE 4, TYPICAL TRANSFER CHARACTERISTICS

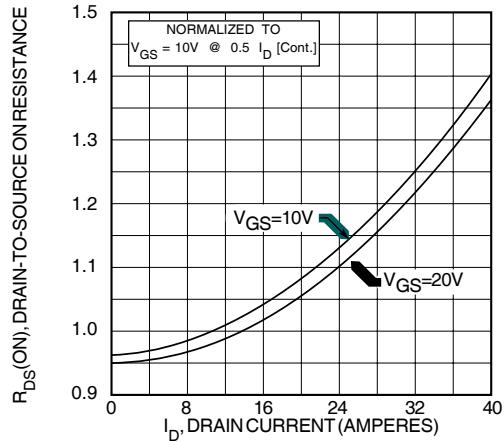

FIGURE 5,  $R_{DS(ON)}$  vs DRAIN CURRENT

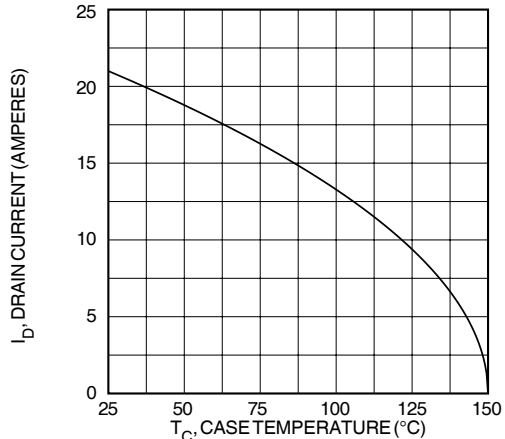

FIGURE 6, MAXIMUM DRAIN CURRENT vs CASE TEMPERATURE

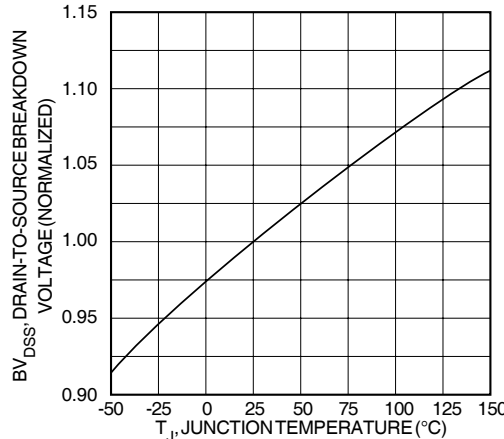

FIGURE 7, BREAKDOWN VOLTAGE vs TEMPERATURE

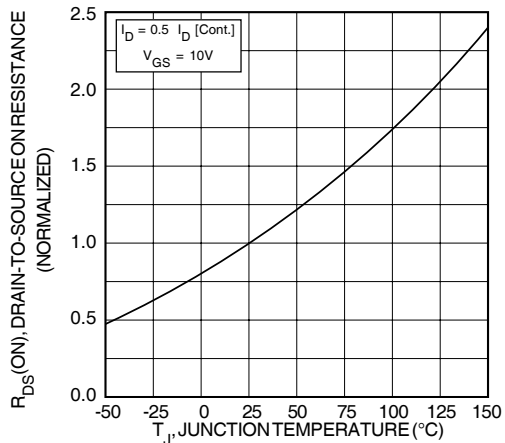

FIGURE 8, ON-RESISTANCE vs. TEMPERATURE

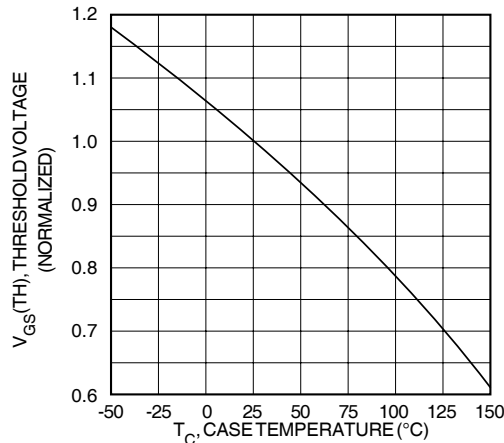

FIGURE 9, THRESHOLD VOLTAGE vs TEMPERATURE

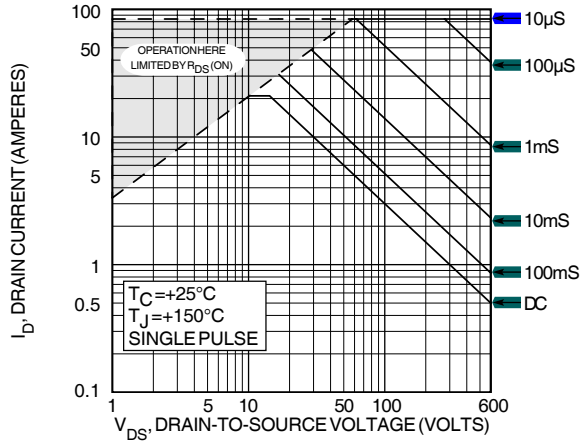

FIGURE 10, MAXIMUM SAFE OPERATING AREA

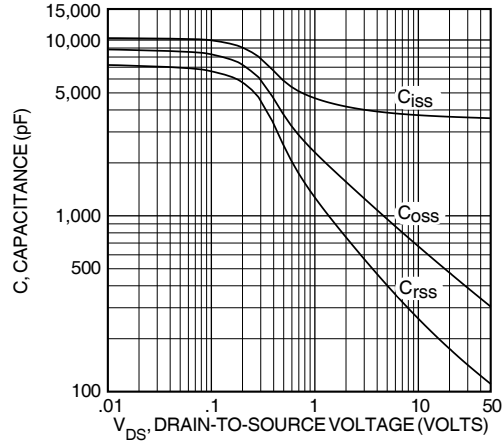

FIGURE 11, TYPICAL CAPACITANCE vs DRAIN-TO-SOURCE VOLTAGE

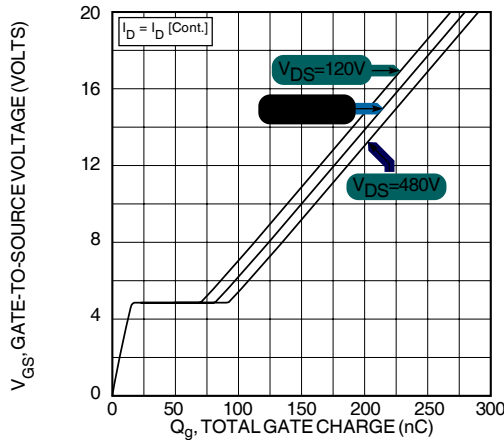

FIGURE 12, GATE CHARGES vs GATE-TO-SOURCE VOLTAGE

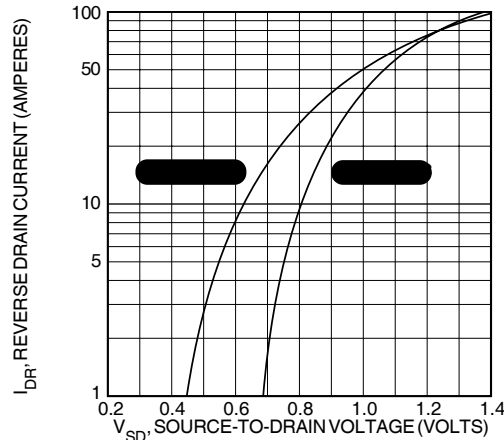
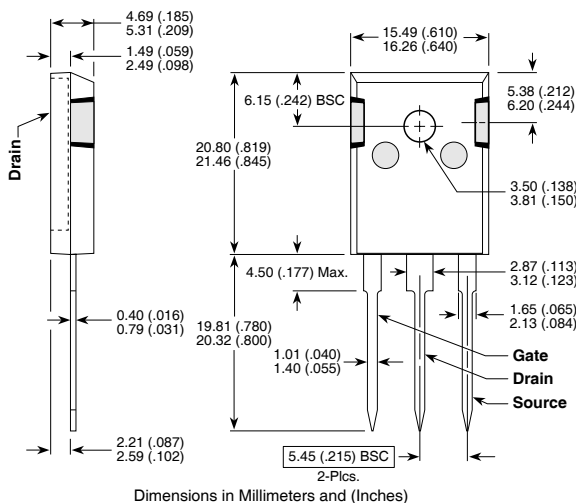

FIGURE 13, TYPICAL SOURCE-DRAIN DIODE FORWARD VOLTAGE

TO-247 Package Outline (BVR)



Dimensions in Millimeters and (Inches)

D<sup>3</sup>PAK Package Outline (SVR)

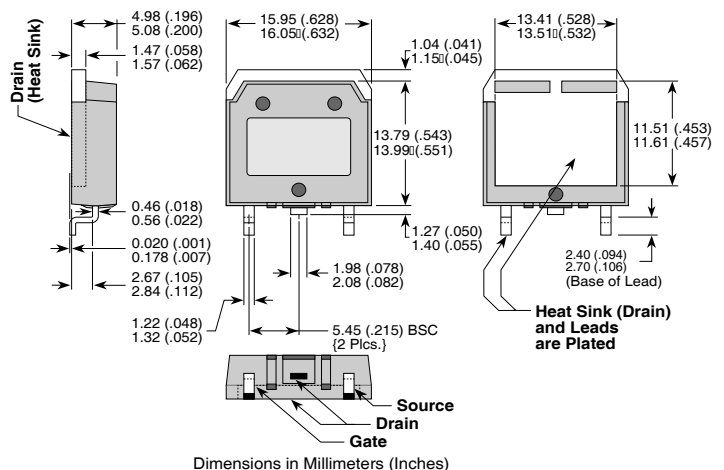

Dimensions in Millimeters (Inches)