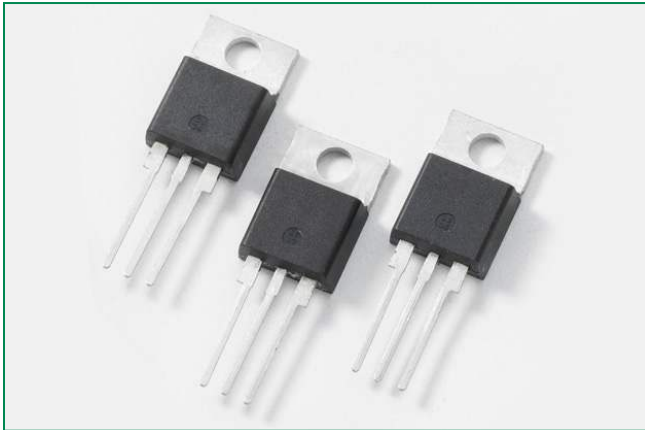


**Qxx30xHx & Qxx35xHx Series**



**Agency Approval**

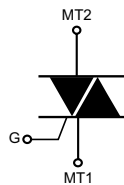
Agency	Agency File Number
	E71639*

\* - L Package and 30A only.

**Main Features**

Symbol	Value	Unit
$I_{T(RMS)}$	30 or 35	A
$V_{DRM}/V_{RRM}$	400 or 600	V
$I_{GT(Q1)}$	25 or 50	mA

**Schematic Symbol**



**Description**

The 30 Amp / 35 Amp bi-directional solid state switch series is designed for AC switching and phase control applications such as motor speed and temperature modulation controls, lighting controls, and static switching relays.

Standard type components normally operate in Quadrants I & III triggered from AC line.

Standard alternistor triac components operate with in-phase signals in Quadrants I or III and ONLY unipolar negative gate pulses for Quadrant II or III. The alternistor triac will not operate in Quadrant IV. These are used in circuit applications requiring a high dv/dt capability.

**Features & Benefits**

- RoHS Compliant
- Glass – passivated junctions
- Voltage capability up to 800V
- Surge capability up to 350A at 60 Hz half cycle
- L-Package isolation rating of 2500V rms

**Applications**

Excellent for AC switching and phase control applications such as heating, lighting, and motor speed controls.

Typical applications are AC solid-state switches, industrial power tools, exercise equipment, white goods and commercial appliances.

Alternistor Triacs (no snubber required) are used in applications with extremely inductive loads requiring highest commutation performance.

Internally constructed isolated packages are offered for ease of heat sinking with highest isolation voltage.

**Additional Information**



**Datasheet**



**Resources**



**Samples**

### Absolute Maximum Ratings — Alternistor Triac (3 Quadrants)

Symbol	Parameter			Value	Unit
$I_{T(RMS)}$	RMS on-state current (full sine wave)	Qxx35RH5/Qxx35NH5	$T_c = 90^\circ\text{C}$	35	A
		Qxx30LH5/Qxx30LH3	$T_c = 50^\circ\text{C}$	30	
$I_{TSM}$	Non repetitive surge peak on-state current (full cycle, $T_J$ initial = $25^\circ\text{C}$ )	f = 50 Hz	t = 20 ms	290	A
		f = 60 Hz	t = 16.7 ms	350	
$I^2t$	$I^2t$ Value for fusing	-	$t_p = 8.3$ ms	508	$\text{A}^2\text{s}$
di/dt	Critical rate of rise of on-state current ( $I_G = 200\text{mA}$ with $\leq 0.1\mu\text{s}$ rise time)	f = 120 Hz	$T_J = 125^\circ\text{C}$	100	$\text{A}/\mu\text{s}$
$I_{GTM}$	Peak gate trigger current	$t_p = 20\mu\text{s}$	$T_J = 125^\circ\text{C}$	4	A
$P_{G(AV)}$	Average gate power dissipation		$T_J = 125^\circ\text{C}$	0.5	W
$T_{stg}$	Storage temperature range			-40 to 125	$^\circ\text{C}$
$T_J$	Operating junction temperature range			-25 to 125	$^\circ\text{C}$

### Electrical Characteristics ( $T_J = 25^\circ\text{C}$ , unless otherwise specified) — Alternistor Triac (3 Quadrants)

Symbol	Test Conditions	Quadrant		Qxx35RH5 Qxx35NH5 Qxx30LH5	Qxx30LH3	Unit
$I_{GT}$	$V_D = 12\text{V}$ $R_L = 30\ \Omega$	I – II – III	MAX.	50	25	mA
$V_{GT}$	$V_D = 12\text{V}$ $R_L = 30\ \Omega$	I – II – III	MAX.	2	2	V
$V_{GD}$	$V_D = V_{DRM}$ $R_L = 3.3\ \text{k}\Omega$ $T_J = 125^\circ\text{C}$	I – II – III	MIN.	0.2	0.2	V
$I_H$	$I_T = 400\text{mA}$		MAX.	75	40	mA
dv/dt	$V_D = V_{DRM}$ Gate Open $T_J = 125^\circ\text{C}$	400V 600V	MIN.	475 400	350 250	$\text{V}/\mu\text{s}$
(dv/dt)c	(di/dt)c = 18.9 A/ms $T_J = 125^\circ\text{C}$		MIN.	20	10	$\text{V}/\mu\text{s}$
$t_{gt}$	<b>35A device</b> $I_G = 2 \times I_{GT}$ PW = 15 $\mu\text{s}$ $I_T = 49.5\text{A(pk)}$ <b>30A device</b> $I_G = 2 \times I_{GT}$ PW = 15 $\mu\text{s}$ $I_T = 42.4\text{A(pk)}$		TYP.	3	3	$\mu\text{s}$

Note: xx = voltage/10

### Static Characteristics

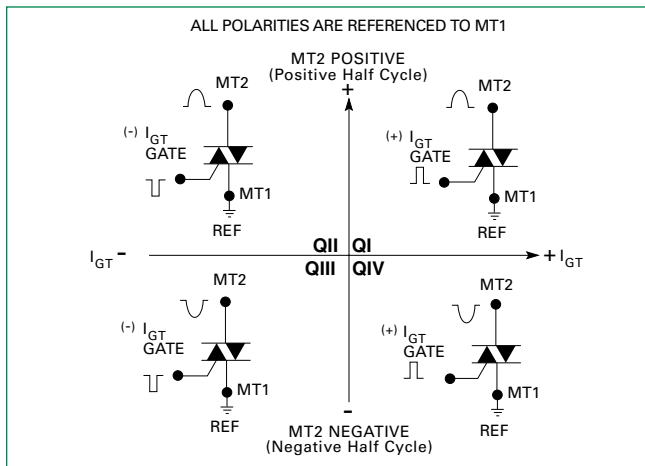
Symbol	Test Conditions				Value	Unit	
$V_{TM}$	35A device $I_{TM} = 49.5A$ $t_p = 380 \mu s$		MAX.		1.5	V	
	30A device $I_{TM} = 42.4A$ $t_p = 380 \mu s$				1.4		
$I_{DRM}$ $I_{RRM}$	$V_D = V_{DRM}/V_{RRM}$	Qxx35RH/NH5	$T_J = 25^\circ C$	400 - 600V	MAX.	10	$\mu A$
		Qxx30LH5 Qxx30LH3	$T_J = 125^\circ C$	400 - 600V		2	mA

### Thermal Resistances

Symbol	Parameter		Value	Unit
$R_{\theta(J-C)}$	Junction to case (AC)	Qxx35RH5 / Qxx35NH5	0.85	-
		Qxx30LH5 / Qxx30LH3	2.30	
$R_{\theta(J-A)}$	Junction to ambient	Qxx35RH5	45	$^\circ C/W$
		Qxx30LH5 / Qxx30LH3	50	

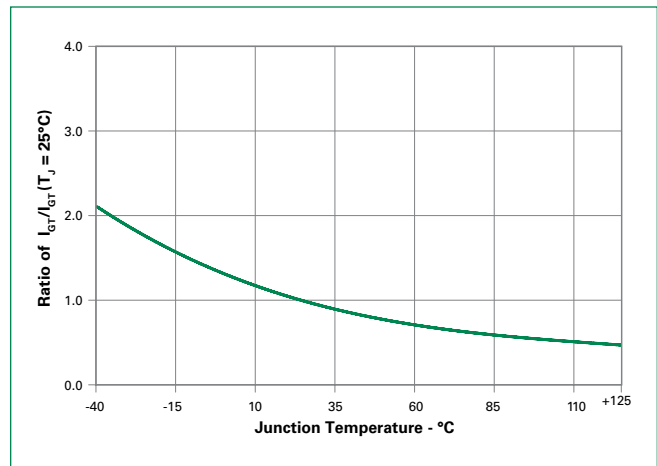
Note: xx = voltage/10

**Figure 1: Definition of Quadrants**

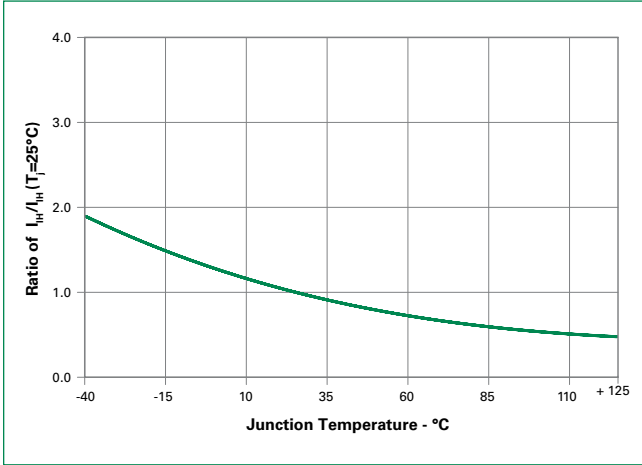


Note: Alternistors will not operate in QIV

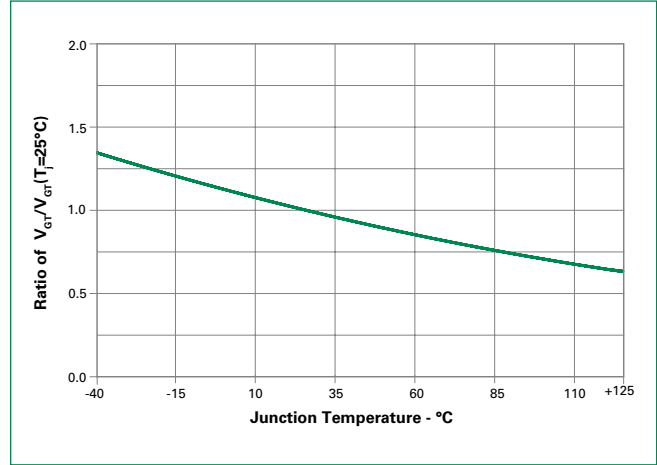
**Figure 2: Normalized DC Gate Trigger Current for All Quadrants vs. Junction Temperature**



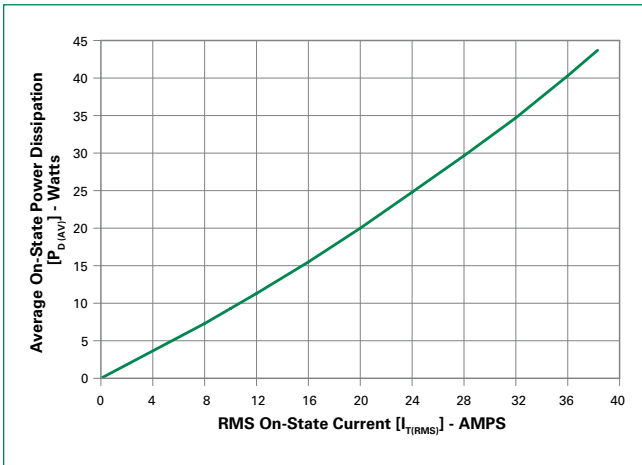
**Figure 3: Normalized DC Holding Current vs. Junction Temperature**



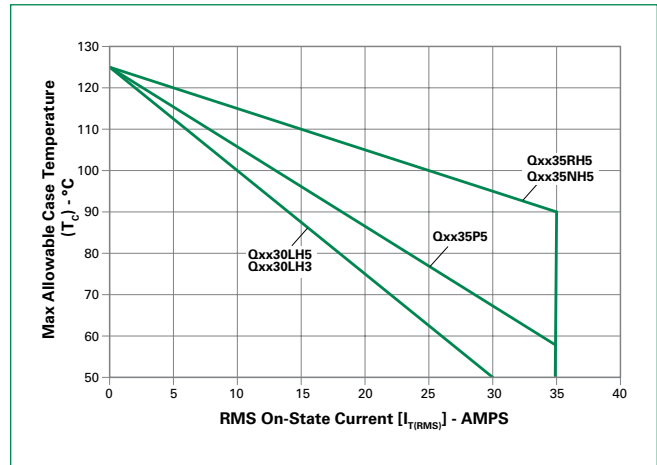
**Figure 4: Normalized DC Gate Trigger Voltage for All Quadrants vs. Junction Temperature**



**Figure 5: Power Dissipation (Typical) vs. RMS On-State Current**

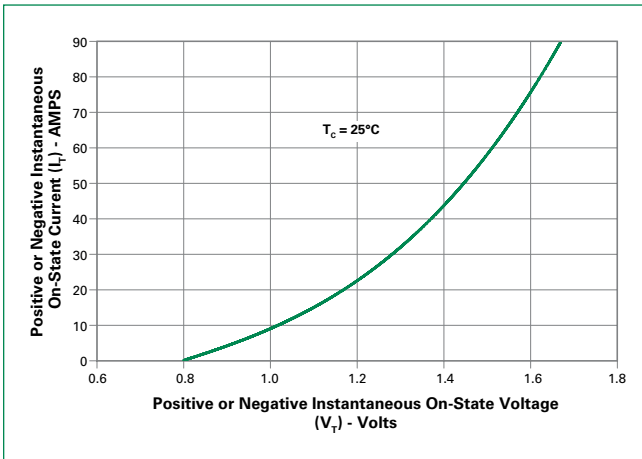


**Figure 6: Maximum Allowable Case Temperature vs. On-State Current**

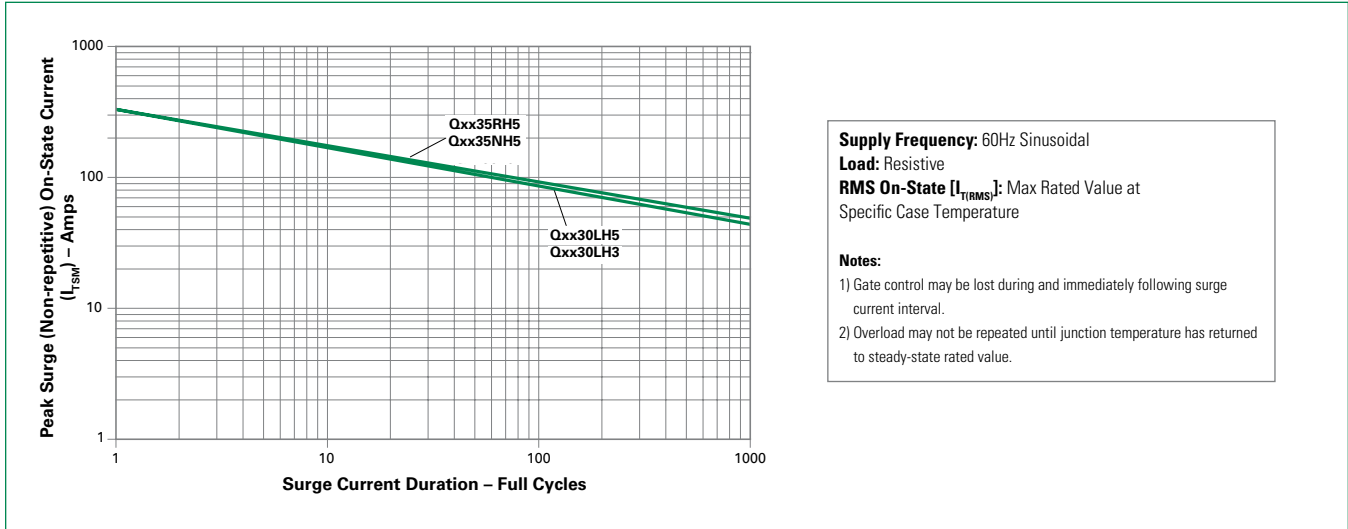


Note: xx = voltage

**Figure 7: On-State Current vs. On-State Voltage (Typical)**



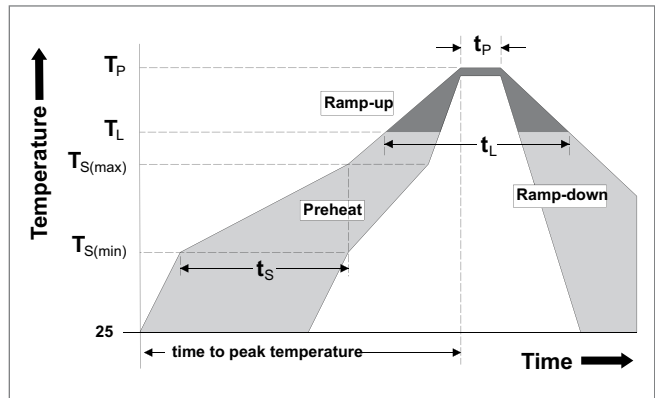
**Figure 8: Surge Peak On-State Current vs. Number of Cycles**



Note: xx = voltage

**Soldering Parameters**

<b>Reflow Condition</b>		Pb – Free assembly
<b>Pre Heat</b>	- Temperature Min ( $T_{s(min)}$ )	150°C
	- Temperature Max ( $T_{s(max)}$ )	200°C
	- Time (min to max) ( $t_s$ )	60 – 180 secs
<b>Average ramp up rate (Liquidus Temp) (<math>T_L</math>) to peak</b>		5°C/second max
<b><math>T_{S(max)}</math> to <math>T_L</math> - Ramp-up Rate</b>		5°C/second max
<b>Reflow</b>	- Temperature ( $T_L$ ) (Liquidus)	217°C
	- Time (min to max) ( $t_s$ )	60 – 150 seconds
<b>Peak Temperature (<math>T_p</math>)</b>		260 <sup>+0/-5</sup> °C
<b>Time within 5°C of actual peak Temperature (<math>t_p</math>)</b>		20 – 40 seconds
<b>Ramp-down Rate</b>		5°C/second max
<b>Time 25°C to peak Temperature (<math>T_p</math>)</b>		8 minutes Max.
<b>Do not exceed</b>		280°C



### Physical Specifications

<b>Terminal Finish</b>	100% Matte Tin-plated.
<b>Body Material</b>	UL Recognized compound meeting flammability rating V-0
<b>Terminal Material</b>	Copper Alloy

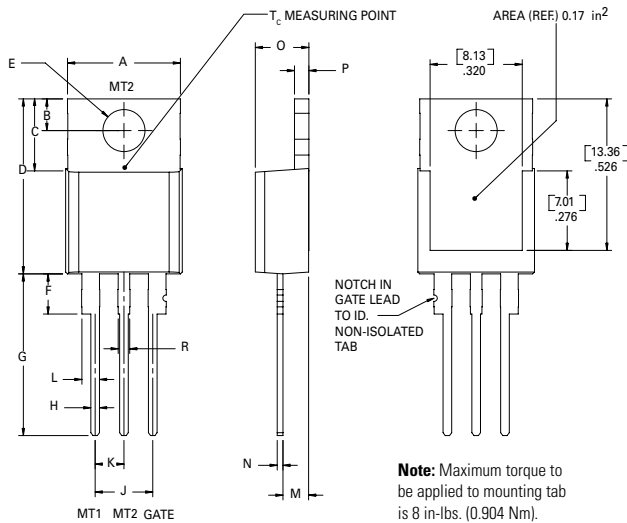
### Design Considerations

Careful selection of the correct component for the application's operating parameters and environment will go a long way toward extending the operating life of the Thyristor. Good design practice should limit the maximum continuous current through the main terminals to 75% of the component rating. Other ways to ensure long life for a power discrete semiconductor are proper heat sinking and selection of voltage ratings for worst case conditions. Overheating, overvoltage (including dv/dt), and surge currents are the main killers of semiconductors. Correct mounting, soldering, and forming of the leads also help protect against component damage.

### Environmental Specifications

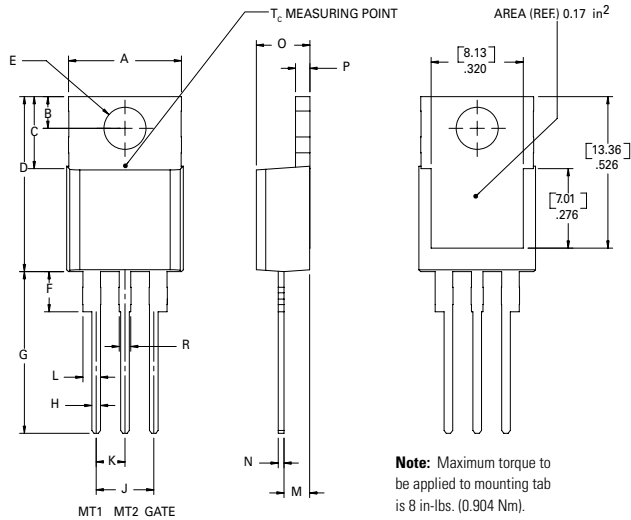
Test	Specifications and Conditions
<b>AC Blocking</b>	MIL-STD-750, M-1040, Cond A Applied Peak AC voltage @ 125°C for 1008 hours
<b>Temperature Cycling</b>	MIL-STD-750, M-1051, 100 cycles; -40°C to +150°C; 15-min dwell-time
<b>Temperature/Humidity</b>	EIA / JEDEC, JESD22-A101 1008 hours; 320V - DC: 85°C; 85% rel humidity
<b>High Temp Storage</b>	MIL-STD-750, M-1031, 1008 hours; 150°C
<b>Low-Temp Storage</b>	1008 hours; -40°C
<b>Thermal Shock</b>	MIL-STD-750, M-1056 10 cycles; 0°C to 100°C; 5-min dwell-time at each temperature; 10 sec (max) transfer time between temperature
<b>Autoclave</b>	EIA / JEDEC, JESD22-A102 168 hours (121°C at 2 ATMs) and 100% R/H
<b>Resistance to Solder Heat</b>	MIL-STD-750 Method 2031
<b>Solderability</b>	ANSI/J-STD-002, category 3, Test A
<b>Lead Bend</b>	MIL-STD-750, M-2036 Cond E

### Dimensions — TO-220AB (R-Package) — Non-Isolated Mounting Tab Common with Center Lead



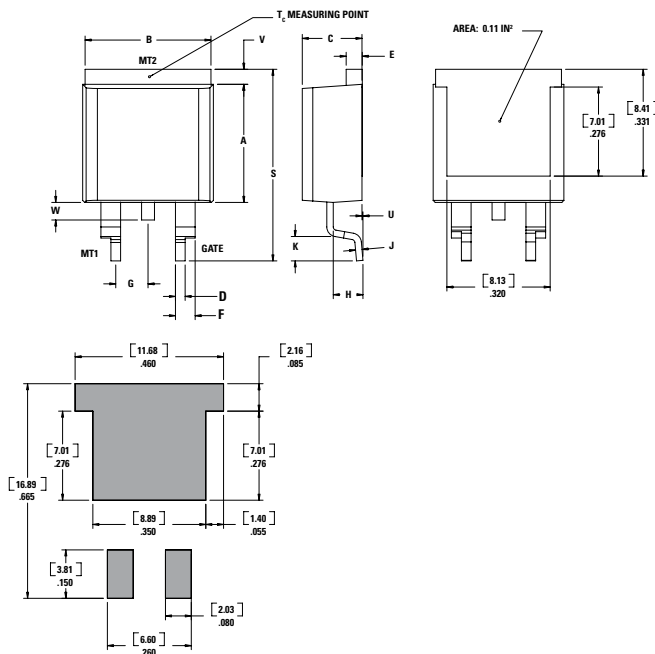
Dimension	Inches		Millimeters	
	Min	Max	Min	Max
<b>A</b>	0.380	0.420	9.65	10.67
<b>B</b>	0.105	0.115	2.67	2.92
<b>C</b>	0.230	0.250	5.84	6.35
<b>D</b>	0.590	0.620	14.99	15.75
<b>E</b>	0.142	0.147	3.61	3.73
<b>F</b>	0.110	0.130	2.79	3.30
<b>G</b>	0.540	0.575	13.72	14.61
<b>H</b>	0.025	0.035	0.64	0.89
<b>J</b>	0.195	0.205	4.95	5.21
<b>K</b>	0.095	0.105	2.41	2.67
<b>L</b>	0.060	0.075	1.52	1.91
<b>M</b>	0.085	0.095	2.16	2.41
<b>N</b>	0.018	0.024	0.46	0.61
<b>O</b>	0.178	0.188	4.52	4.78
<b>P</b>	0.045	0.060	1.14	1.52
<b>R</b>	0.038	0.048	0.97	1.22

### Dimensions — TO-220AB (L-Package) — Isolated Mounting Tab



Dimension	Inches		Millimeters	
	Min	Max	Min	Max
A	0.380	0.420	9.65	10.67
B	0.105	0.115	2.67	2.92
C	0.230	0.250	5.84	6.35
D	0.590	0.620	14.99	15.75
E	0.142	0.147	3.61	3.73
F	0.110	0.130	2.79	3.30
G	0.540	0.575	13.72	14.61
H	0.025	0.035	0.64	0.89
J	0.195	0.205	4.95	5.21
K	0.095	0.105	2.41	2.67
L	0.060	0.075	1.52	1.91
M	0.085	0.095	2.16	2.41
N	0.018	0.024	0.46	0.61
O	0.178	0.188	4.52	4.78
P	0.045	0.060	1.14	1.52
R	0.038	0.048	0.97	1.22

### Dimensions — TO-263 (N-Package) — D<sup>2</sup> Pak Surface Mount



Dimension	Inches		Millimeters	
	Min	Max	Min	Max
A	0.360	0.370	9.14	9.40
B	0.380	0.420	9.65	10.67
C	0.178	0.188	4.52	4.78
D	0.025	0.035	0.64	0.89
E	0.045	0.060	1.14	1.52
F	0.060	0.075	1.52	1.91
G	0.095	0.105	2.41	2.67
H	0.092	0.102	2.34	2.59
J	0.018	0.024	0.46	0.61
K	0.090	0.110	2.29	2.79
S	0.590	0.625	14.99	15.88
V	0.035	0.045	0.89	1.14
U	0.002	0.010	0.05	0.25
W	0.040	0.070	1.016	1.78

### Product Selector

Part Number	Voltage			Gate Sensitivity Quadrants		I <sub>T(RMS)</sub>	Type	Package
	400V	600V	800V	I – II – III	IV			
Qxx35RH5	X	X		50 mA		35A	Alternistor Triac	TO-220R
Qxx35NH5	X	X		50 mA		35A	Alternistor Triac	TO-263 D <sup>2</sup> -PAK
Qxx30LH5	X	X		50 mA		30A	Alternistor Triac	TO-220L
Qxx30LH3	X	X		25 mA		30A	Alternistor Triac	TO-220L

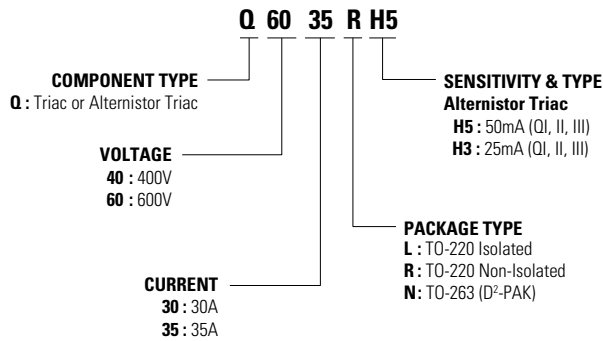
Note: xx = Voltage/10

### Packing Options

Part Number	Marking	Weight	Packing Mode	Base Quantity
Qxx35RH5TP	Qxx35RH5	2.20 g	Tube	1000 (50 per tube)
Qxx35NH5TP	Qxx35NH5	1.60 g	Tube	1000 (50 per tube)
Qxx35NH5RP	Qxx35NH5	1.60 g	Embossed Carrier	500
Qxx30LH5TP	Qxx30LH5	2.20 g	Tube	1000 (50 per tube)
Qxx30LH3TP	Qxx30LH3	2.20 g	Tube	1000 (50 per tube)

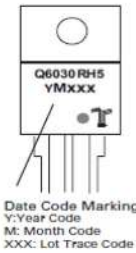
xx = voltage/10

### Part Numbering System



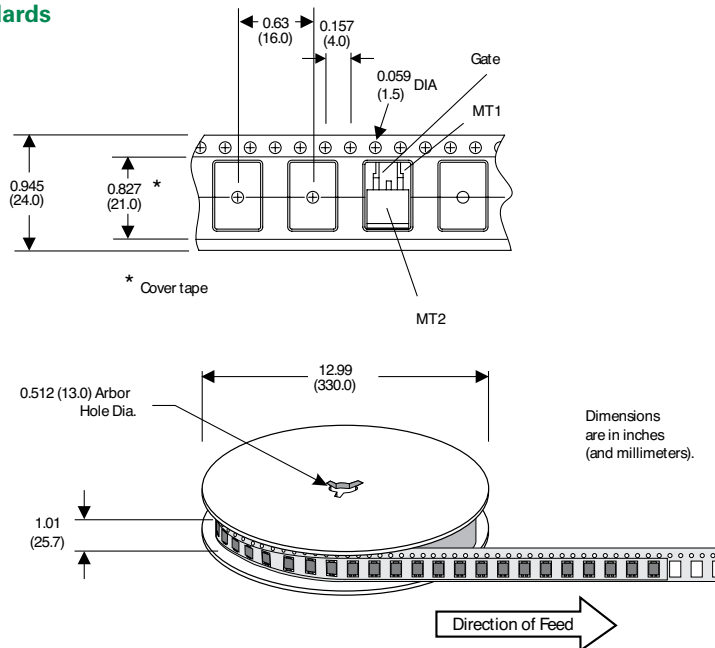
### Part Marking System

TO-220 AB - (L and R Package)  
TO-263 AB - (N Package)



### TO-263 Embossed Carrier Reel Pack (RP) Specifications

Meets all EIA-481-2 Standards



**Disclaimer Notice** - Information furnished is believed to be accurate and reliable. However, users should independently evaluate the suitability of and test each product selected for their own applications. Littelfuse products are not designed for, and may not be used in, all applications. Read complete Disclaimer Notice at <http://www.littelfuse.com/disclaimer-electronics>.

©2019 Littelfuse, Inc  
Specifications are subject to change without notice.  
Revised: B0.12/10/20