

THIS COPY IS PROVIDED ON A RESTRICTED BASIS AND IS NOT TO BE USED IN ANY WAY DETRIMENTAL TO THE INTERESTS OF PANDUIT CORP.

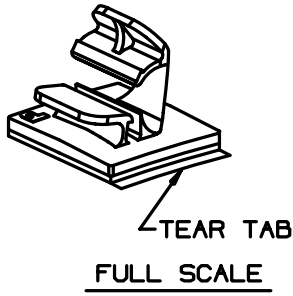
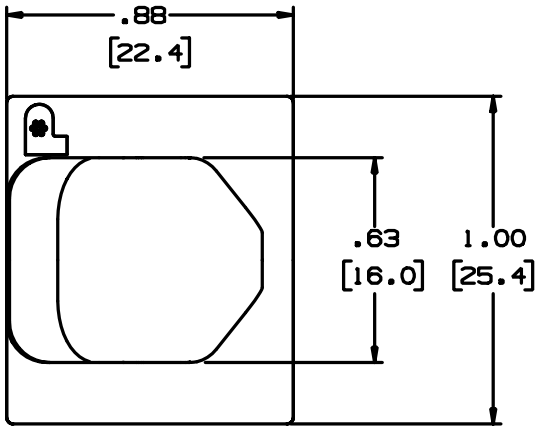

PANDUIT PART NUMBER*	MAXIMUM CABLE DIA. in. (mm)	WEIGHT lbs. (g)/100pcs
LWC25-A	.25 (6.4)	.56 (255)

- NOTES:
- \* 1) SEE CURRENT PRICE SHEET FOR PART NUMBER SUFFIX DESIGNATION, FOR PACKAGE SIZE.
  - 2) MOUNT IS DESIGNED TO SUPPORT .45lbs [204g] MAX WEIGHT ON A CLEAN DRY SMOOTH SURFACE.

- TO APPLY LATCHING WIRE CLIP:
1. REMOVE PROTECTIVE LINER
  2. PLACE IN DESIRED LOCATION
  3. APPLY PRESSURE TO TOP OF LATCHING WIRE CLIP

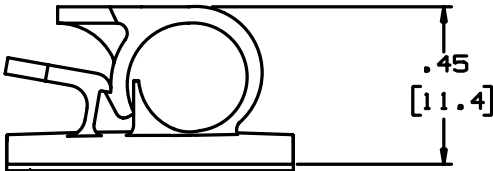

NO WARRANTY, EXPRESSED OR IMPLIED, IS MADE BY PANDUIT WITH RESPECT TO ADHESIVE BOND PERFORMANCE. AMONG OTHER THINGS, THE CONDITIONS UNDER WHICH THESE MOUNTS MAY BE APPLIED, AND/OR THE SURFACE TO WHICH THEY MAY BE APPLIED, ARE BEYOND PANDUIT'S CONTROL.

ADHESIVE BACKING: PRESSURE SENSITIVE FOAM .04 [1.0] THICK WITH PROTECTIVE LINER TO EXTEND BEYOND EDGE FORMING A TEAR TAB.

DIMENSIONS IN BRACKETS ARE METRIC [mm]

CAD FILENAME/LAYER# GB0285BA\_PB\_LWC25A\_02

**PANDUIT** CORP. TINLEY PARK, ILLINOIS

LWC25-A, LATCHING WIRE CLIP

UNLESS OTHERWISE SPECIFIED, DIMENSIONAL TOLERANCES ARE:  
 (.X) ±0.05 [1.3] (.XXX) ±0.010 [0.25]  
 (.XX) ±0.02 [0.5] ANGLES ± 5°

UNLESS OTHERWISE SPECIFIED, ALL DIMENSIONS ARE GIVEN IN INCHES, THIRD ANGLE PROJECTION.

DRAWN BY

JRJ

MAT'L:

NYLON 6/6

SCALE

2X

DATE

10-19-92

DRAWING NO.

GB0285BA

DWG

A

SIZE

REV	DATE	BY	CHK	DESCRIPTION	ECN	R	CUST	SUP
2	1-8-98	CGSM		CHANGED NOTE 3 ON APPLICATION INSTRUCTIONS	GB0285BA	2		
1	12-18-92	JRJ		CHG. WT. .56 WAS .66 ADDED .56 DIM.	GB0285BA	1		
R	10-19-92	JRJ		INITIAL RELEASE	GB0285BA	R		