

PART NUMBER	ENGINEERING NO.	LENGTH
1300240337	DNF10A-M010	3' 3" +2.19 - 0 [1.0M +55.6 - 0]
1300240338	DNF10A-M030	9' 10" +3.50 - 0 [3.0M +88.9 - 0]
1300240287	DNF10A-M050	16' 5" +6.50 - 0 [5.0M +165.1 - 0]

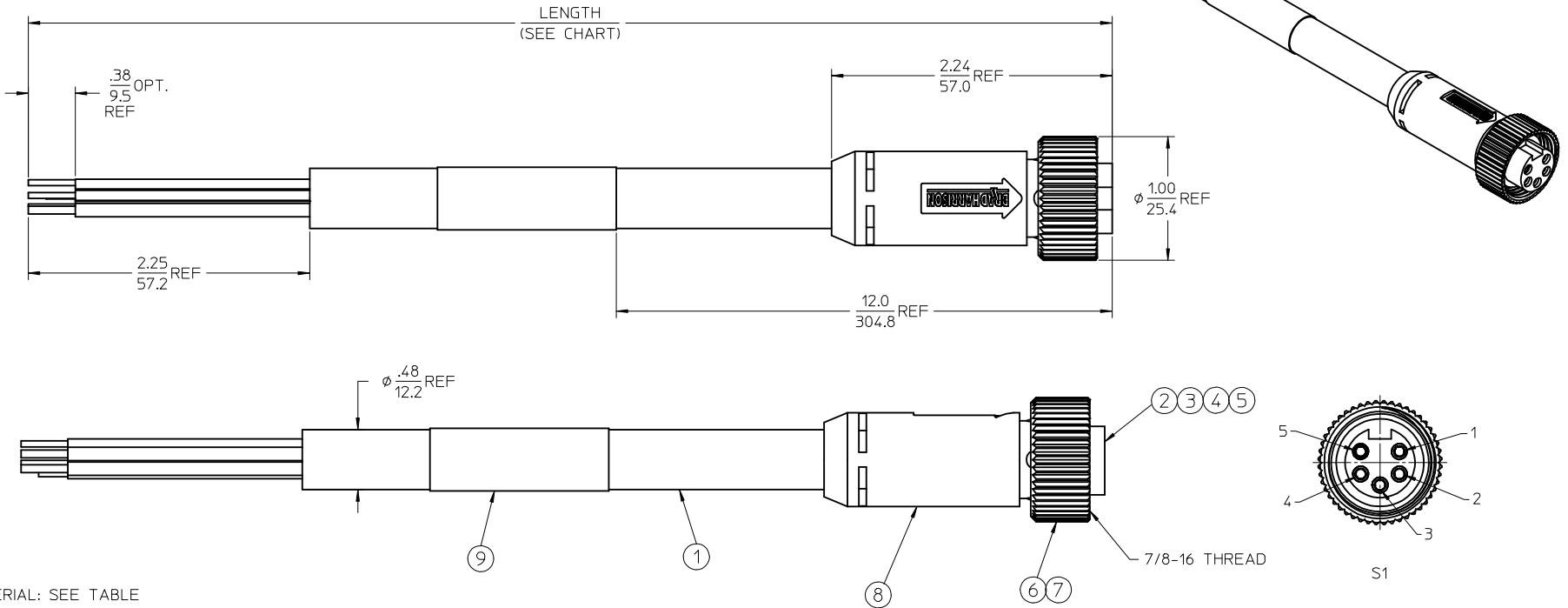

NOTES:

1. MATERIAL: SEE TABLE
2. FINISHES: SEE TABLE
3. CABLE ASSEMBLIES ARE BAGGED SEPARATELY IN POLY BAGS WITH BARCODE LABEL ATTACHED TO OUTSIDE OF BAG
4. WRAP LABEL IS MARKED WITH P/N, DATE CODE VOLTAGE & AMPERAGE
5. MATES WITH: MINI CHANGE, A-SIZE 5 POLE RECEPTACLE
6. ELECTRICAL SPECIFICATIONS:
VOLTAGE RATING: 300V
CURRENT RATING: 4 AMPS
7. ASSEMBLY IS RoHS COMPLIANT

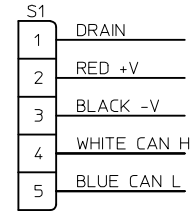

WIRING DIAGRAM

ITEM	QTY.	DESCRIPTION	MATERIAL	FINISH
9	1	LABEL	PLASTIC FILM	BLACK/YELLOW
8	1	OVERMOLD	PVC	GRAY
7	1	COUPLING NUT	ZINC DIE CAST	BLACK
6	1	FRICTION RING	NYLON	WHITE
5	5	SOCKET SLEEVE	ST. STEEL	
4	3	CONTACT SOCKET, 18 AWG	BRASS	GOLD PLATED
3	2	CONTACT SOCKET, 15 AWG	BRASS	GOLD PLATED
2	1	INSERT, FEMALE, 5 POLE	PVC	GRAY
1	1	CABLE - MID. DEV-NET, TRUNK, 18/2, 15/2	PVC JACKET	GRAY

RELEASED EC NO: WNA2010-0048 DRAWN BY: B.RUPERT 2009/07/17 CHKD: WOODMAN APPR: J.MURPHY 2009/07/20	QUALITY SYMBOLS ▽=0 ▽=0	GENERAL TOLERANCES (UNLESS SPECIFIED)		DIMENSION STYLE IN/MM	SCALE 1.5:1	DESIGN UNITS INCH	THIRD ANGLE PROJECTION		
		4 PLACES ± --- ± --- 3 PLACES ± --- ± --- 2 PLACES ± --- ± --- 1 PLACE ± --- ± ---	mm INCH	DRAWN BY B.RUPERT	DATE 2009/07/07	CHECKED BY B.WOODMAN	DATE 2009/07/07	MINI-CHANGE 5 POLE FEMALE, DEVICE NET TRUNK CABLE THK FLEX	
		ANGULAR ±1/2°		APPROVED BY J.MURPHY	DATE 2009/07/07	MOLEX INCORPORATED		MATERIAL NO.	DOCUMENT NO.
		DRAFT WHERE APPLICABLE MUST REMAIN WITHIN DIMENSIONS		SEE CHART		SD-130024-014		SHEET NO. 1 OF 1	

THIS DRAWING CONTAINS INFORMATION THAT IS PROPRIETARY TO MOLEX INCORPORATED AND SHOULD NOT BE USED WITHOUT WRITTEN PERMISSION