



QLUV07M3QCV  
3535 3W 60D UVA LED



## Product Outline:

The high output ceramic type of 3535 UV LEDs with 60 degree quartz glass lens. High power UV LED series are designed for high current operation and high power output applications. Quelighting UV LED is ideal UV light source for curing, printing, and detecting applications

## Features:

- 365nm
- High Power UV LED
- Quartz glass lens
- Max. current = 1000mA
- Package Dimension = 3.5mm X 3.5mm X 2.48mm
- Ceramic substrate
- Low thermal resistance
- View angle = 60 degree
- RoHS compliant
- ESD 4KV
- Custom Bin available upon special request

## Application:

- UV gluing, UV curing, UV marking
- Printing and Coating
- Adhesive
- Medical applications
- Industrial facility applications

## Compliance and Certification:



## Mechanical Property: (Dimension)

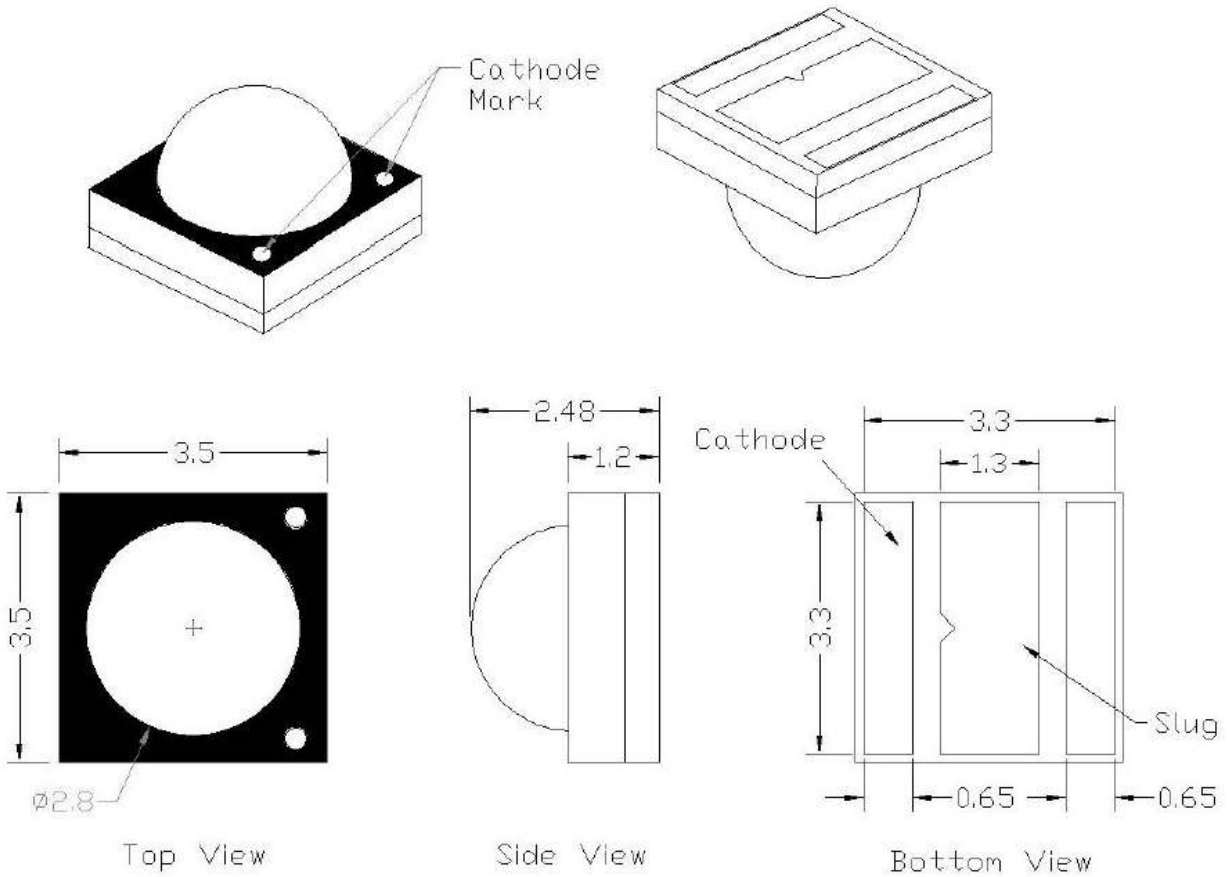

### Circuit Diagram

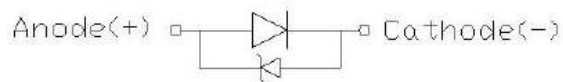

### Note:

1. All dimension in millimeters
2. tolerance is  $\pm 0.2$ mm
3. Please do not use a force of over 3kgf impact or pressure on the lens of the LED, otherwise it will cause a catastrophic failure.



## Recommended Solder footprint:

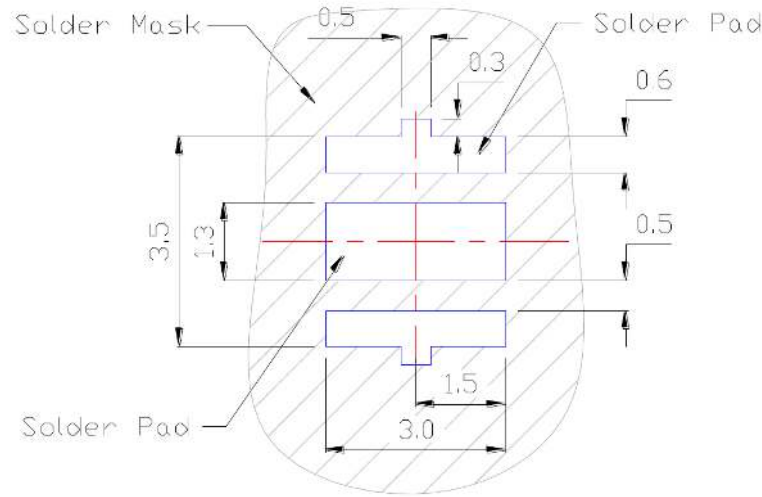

Note:

1. All dimension in millimeters
2. The drawing without tolerances is for reference only
3. Suggest stencil T=0.12 mm

## Electrical / Optical Characteristic

(T=25°C)

Product	View angle	I <sub>F</sub> (mA)	V <sub>F</sub> (V)		Wavelength (nm)	Radiant Power(mW)	
			Typ.	max		min	typ.
QLUV07M3QCV	60	700	3.7	4.0	365-370	755	950

- (1) The Forward Voltage tolerance is  $\pm 0.1V$
- (2) The Peak wavelength tolerance is  $\pm 2$
- (3) The Radiant power is  $\pm 7\%$

## Absolute Maximum Rating

(T=25°C)

Part #	P <sub>d</sub> (mW)	I <sub>F</sub> (mA)	I <sub>FP</sub> (mA)*	V <sub>R</sub> (V)	T <sub>OP</sub> (°C)	T <sub>ST</sub> (°C)	T <sub>j</sub> (°C)**	T <sub>SOL</sub> (°C)**	R <sub>th(J-S)</sub> (C/W)***
QLUV07M3QCV	4000	1000	1100	-5	-40 - 85	-40 - 100	125	260	8

\*Duty 1/10 @ 10Khz

\*\* Junction Temperature

\*\*\* IR Reflow for no more than 10 sec @ 260 °C

\*\*\*\* Thermal resistance is calculated from junction to solder



### Peak Wavelength Binning

Wavelength Rank @ 700mA			
Code name	Low	High	Units
U365	365	370	nm

### Forward Voltage (V<sub>F</sub>) Bin:

VF rank @ 700mA			
Code name	Low	High	Units
45	3.2	3.4	V
67	3.4	3.6	
89	3.6	3.8	
AB	3.8	4.0	

The forward voltage tolerance is  $\pm 0.1V$

### Radiant Power Binning:

Radiant Power rank (mW) @ 700mA			
Code name	Low	High	Units
T2	755	830	mW
U1	830	910	
U2	910	1000	
V1	1000	1100	

luminous flux tolerance is  $\pm 7\%$



## Characteristic Curves

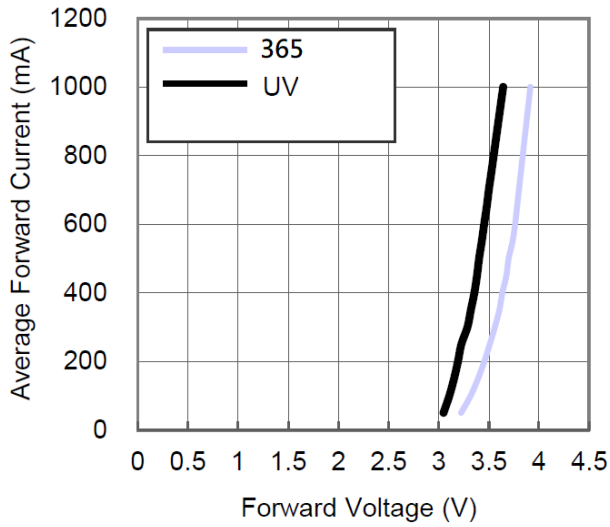

Forward Voltage vs. Forward Current

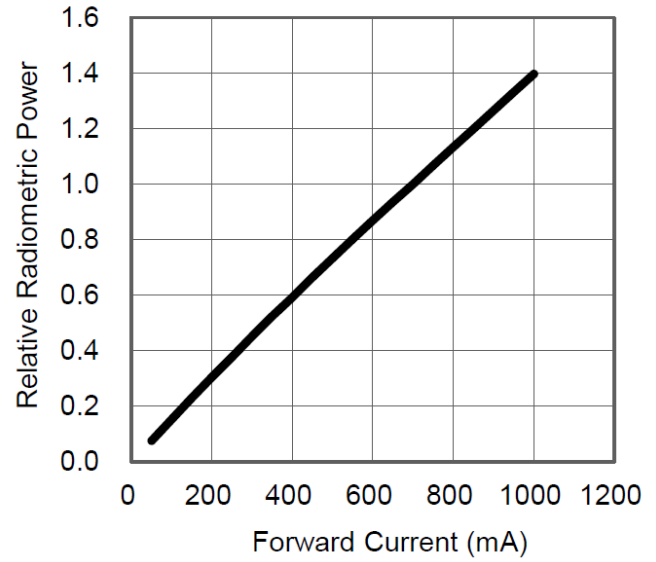

Forward current vs. Relative luminous intensity

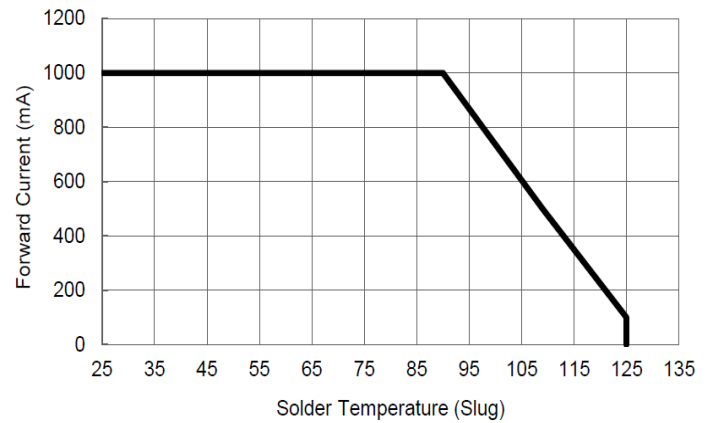
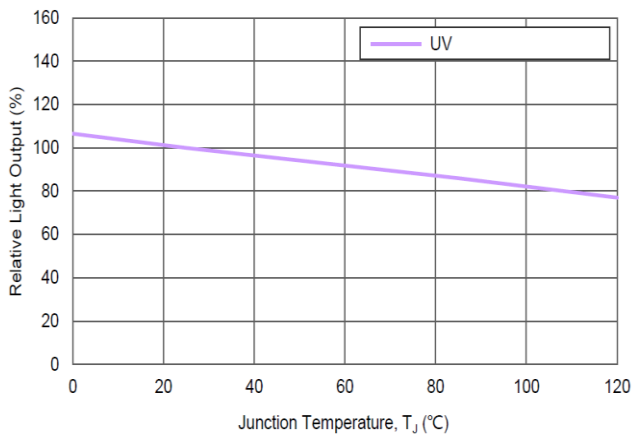

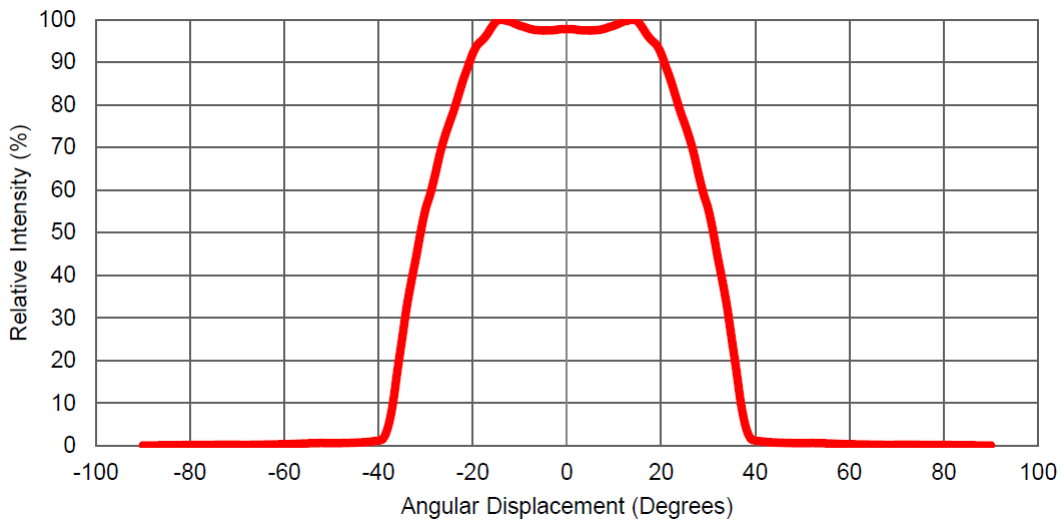

Radiation Pattern for **60** degree

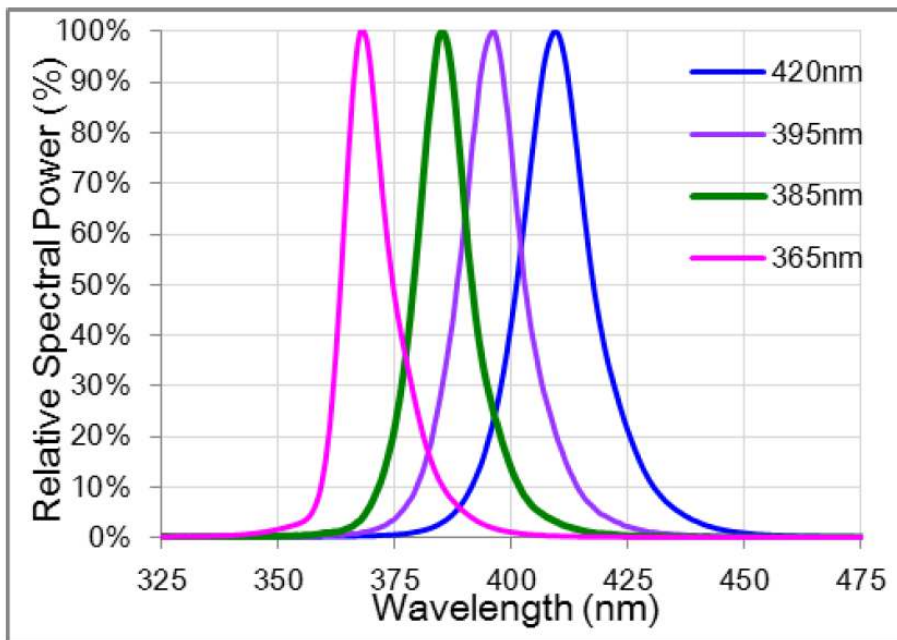

Spectrum Distribution



**■ Reliability test:**

No	Item	Condition	Time/Cycle	Sample size
1	Steady State Operating Life of Room Temperature	25°C Operating	1000 Hrs	20 pcs
2	Steady State Operating Life of Low Temperature -40°C	-40°C Operating	1000 Hrs	20 pcs
3	Steady State Operating Life of Low Temperature 60°C	60°C Operating	1000 Hrs	20 pcs
4	Steady State Operating Life of Low Temperature 85°C	85°C Operating	1000 Hrs	20 pcs
5	Low temperature storage -40°C	-40°C Storage	1000 Hrs	20 pcs
6	High temperature storage 100°C	100°C Storage	1000 Hrs	20 pcs
7	Steady State Operating Life of High Humidity Heat 60°C/90%	60°C/90% Operating	1000 Hrs	20 pcs
8	Steady State Pulse Operating Life Condition	25°C 10Hz duty=1/10 Operating	200 Cycle	20 pcs
9	Resistance to soldering heat on PCB (JEDEC MSL3)	pre-store@60°C, 60%RH for 52hrs Tslid max.=260 10sec	3 Times	20 pcs
10	Heat Cycle Test (JEDEC MRC)	25°C~65°C~-10°C, 90%RH, 24hr/1cycle	10 Cycle	20 pcs
11	Thermal shock	-40°C / 20min~ 5min~125°C /20min	100 Cycle	20 pcs

**■ Judgment Criteria:**

Item	Symbol	Test Condition	Judgment Criteria
Forward Voltage	Vf	700 mA	$\Delta Vf < 10\%$
Luminous Flux	Iv	700 mA	$\Delta Iv < 30\%$





## Solder Profile:

-The recommended reflow soldering profile is as follows (temperatures indicated are as measured on the surface of the LED resin):

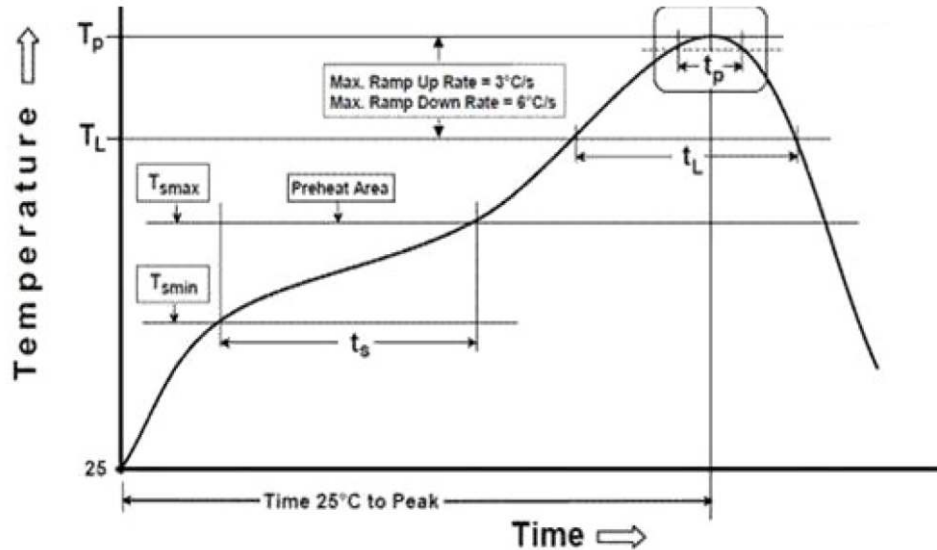

Profile Feature	Sn-Pb Eutectic Assembly	Pb-Free Assembly
Temperature Min( $T_{smin}$ )	100°C	150°C
Temperature Max( $T_{smax}$ )	150°C	200°C
Time( $t_a$ ) from ( $T_{smin}$ to $T_{smax}$ )	60-120 seconds	60-120 seconds
Ramp-up rate( $T_L$ to $T_p$ )	3°C/second max.	3°C/second max.
Liquidous Temperature( $T_L$ )	183°C	217°C
Time( $t_L$ ) maintained above $T_L$	60-150 seconds	60-150 seconds
Peak package body temperature( $T_p$ )	235°C	260°C
Time within 5°C of Actual Peak temperature ( $t_p$ )	20seconds*	30 seconds*
Ramp-down rate( $T_p$ to $T_L$ )	6°C/second max.	6°C/second max.
Time 25°C to peak temperature	6 minutes max.	8 minutes max.
* Tolerance for peak profile temperature ( $T_p$ ) is defined as a supplier minimum and a user maximum.		

Notes:

- We recommend using the M705-S101-S4 solder paste from SMIC (SenjuMetal Industry Co., Ltd.) for lead-free soldering.



- **Do not use solder pastes with post reflow flux residue >47%. (58Bi-42Sn eutectic alloy, etc) This kind of solder pastes may cause a reliability problem to LED**
- All temperatures refer to topside of the package, measured on the package body surface.
- Repairing should not be done after the LEDs have been soldered. When repairing is unavoidable, a double-head soldering iron should be used. It should be confirmed beforehand whether the characteristics of the LEDs will or will not be damaged by repairing.
- Reflow soldering should not be done more than three times
- When soldering, do not put stress on the LEDs during heating.
- After soldering, do not warp the circuit board.

## Taping & Packing:

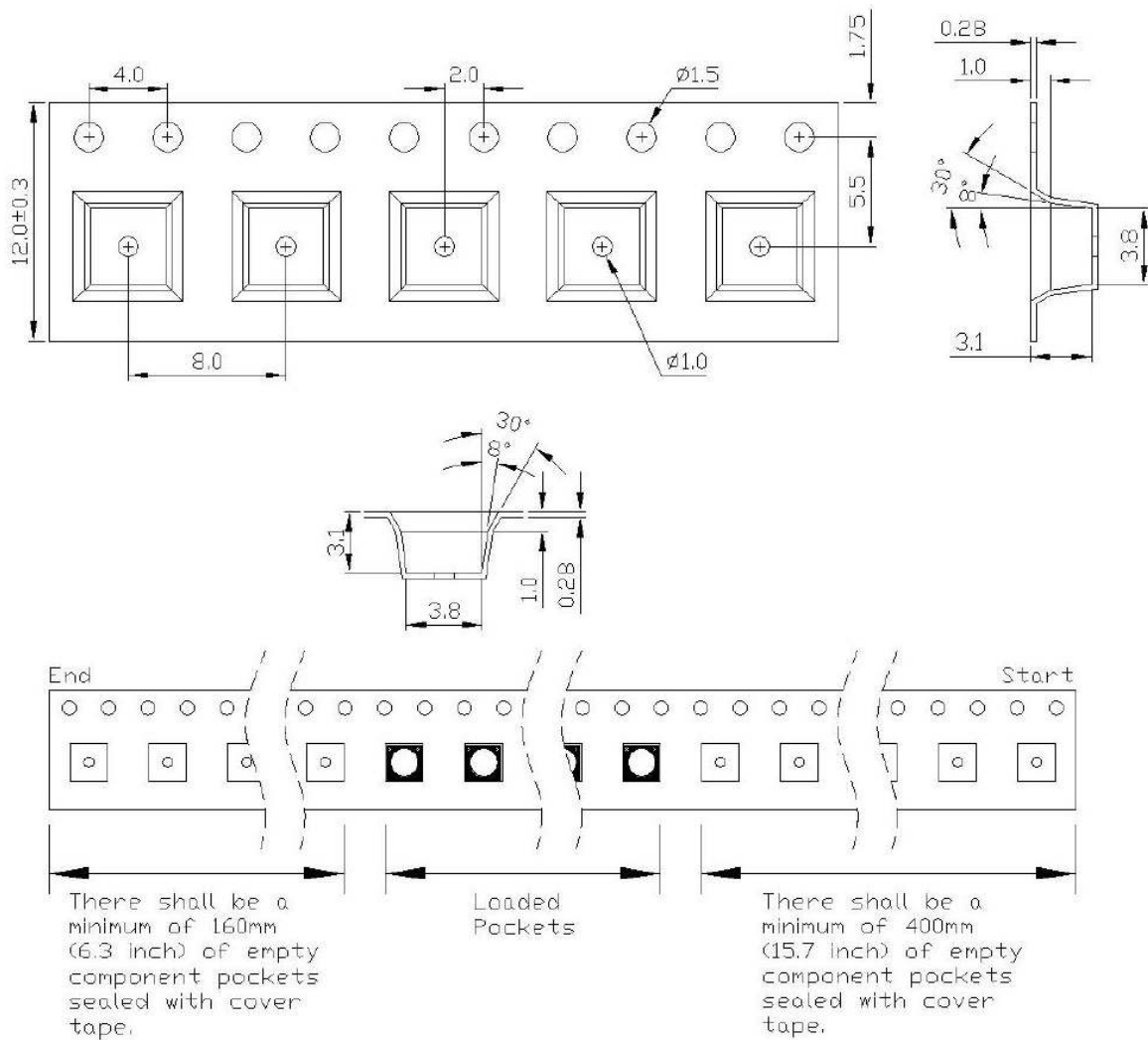

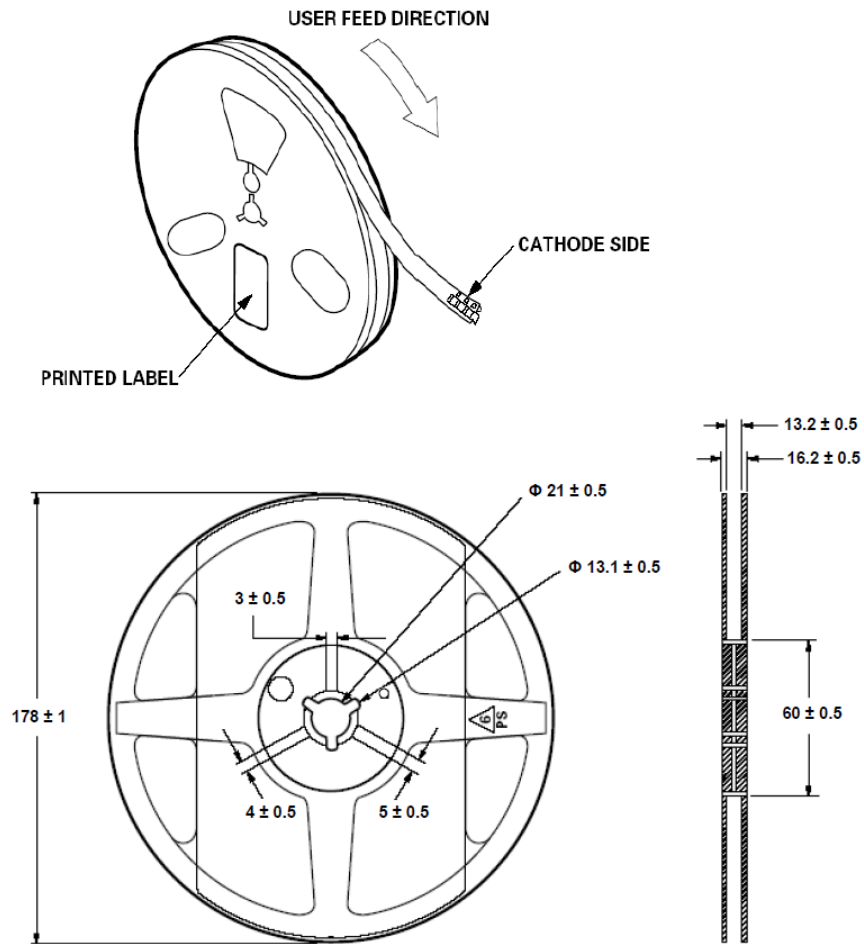

Notes:

1. Drawing not to scale.
2. All dimensions are in millimeters.
3. Unless otherwise indicated, tolerances are  $\pm 0.10$ mm.



## Handling Precautions

- LEDs are ESD (electrostatic discharge) sensitive; static electricity and surge voltages seriously damage UV LEDs and can result in product failure
  - Use proper ESD protection, including grounded wrist straps, ESD footwear and clothes
  - Ensure that tools, jigs and machines being used are properly grounded
  - LED mounting equipment should include protection against voltage surge
  - 
  - The UVC LED is not protected by a lens and requires careful handling
- 
- Do not handle the LED with bare hands as it may contaminate the LED surface and affect the optical characteristics.
  - Avoid touching the LED die
  - Do not use adhesives that outgas organic vapor
  - Dropping the product may cause damage
  - If handling the product with tweezers, use only the side of the package and be careful not to apply excessive force
  - Proper thermal management is required to prevent warpage and damage to the modules and its components.
  - Do not apply mechanical force or excess vibration during handling or normal operation

## Storage Precautions

Please do not open the moisture proof package (with silica desiccant).more than one week. This may cause the leads of LED discoloration.

We recommend storing LEDs in a dry box once moisture proof bag is opened.

The recommended storage conditions are temperature 5 to 30°C and humidity less than 40% RH.

It is also recommended to restore the LEDs into the moisture proof bag and reseal it.

## Notes for handling Quartz lens LEDs

- Avoid touching the quartz lens especially by sharp tools such as Tweezers.
- Avoid leaving fingerprints on the quartz lens.
- Please store the LEDs away from dusty areas or seal the product against dust.
- Under SMT production, please avoid the mechanical pressure on the quartz lens.
- Please do not mold over the quartz lens with another resin. (epoxy, urethane, etc)



## Eye Safety Guidelines

The LED emits high intensity ultraviolet (UV) light, which is harmful to skin and eyes. UV light is hazardous to skin and may cause cancer.

- 1) Avoid looking directly at the UV light: Wear protective glasses/goggle with ANSI Z87 rated.
- 2) Wear facial shield / Lab Coat with long sleeve / Gloves to cover skin may exposed to UVC LEDs.
- 3) Attach warning labels on products/systems that is composed with UV LEDs.

## Samples of Warning label:

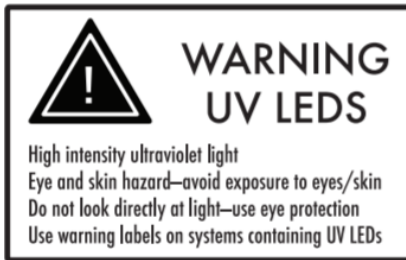

## Labeling

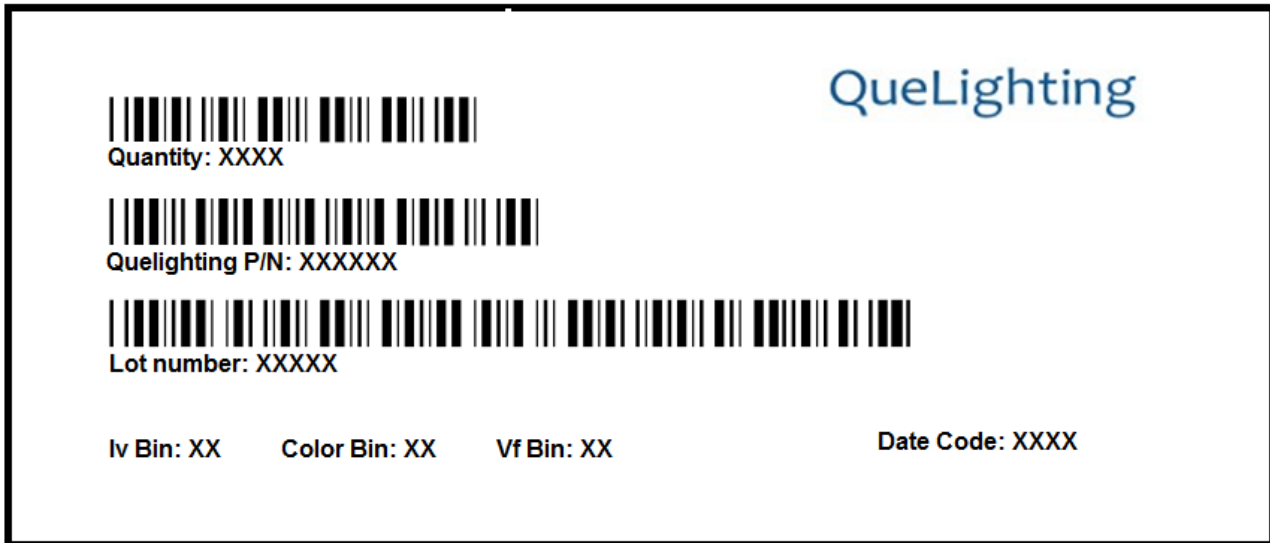

### Ordering Information:

Part #	Multiple Quantities	Quantity per Reel
QLUV07M3QCV		250, 500 pcs

### Revision History:

Revision Date:	Changes:	Version #:
09-23-2020	Initial release	1.0

