

PAGE 1/3	ISSUE 28-06-17B	SERIES NEX10	PART NUMBER R180252007
----------	-----------------	--------------	-------------------------------

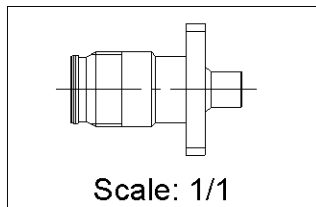

PANEL CUT OUT

	mm	
	Maxi	mini
A	6.7	6.5
B	M3x0.5	
C	8.65	8.55
D	13.45	13.35

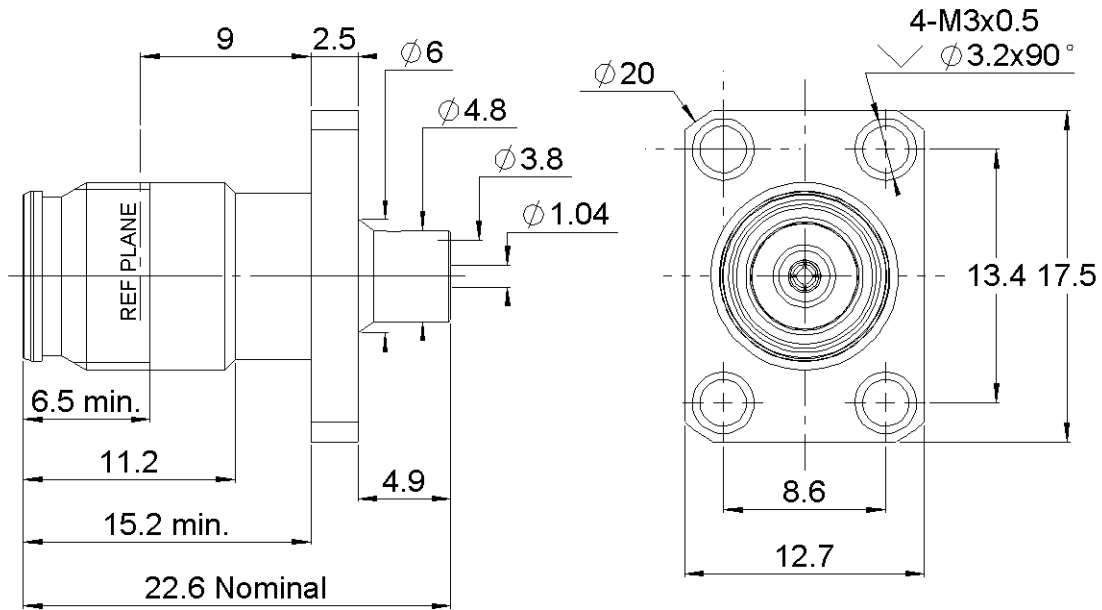
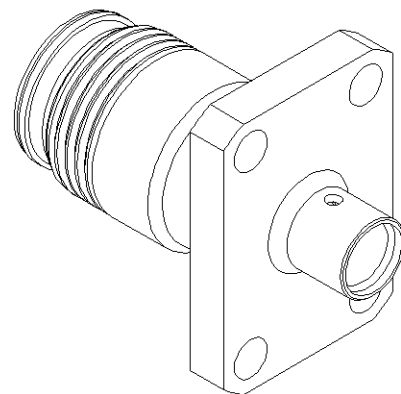

All dimensions are in mm. Tolerances according ISO 2768 m-H

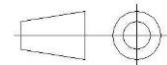

COMPONENTS	MATERIALS	PLATING (μm)
Body	BRASS.	BBR
Center contact	BERYLLIUM COPPER	SILVER
Outer contact		
Insulator	PTFE	
Gasket		
Others parts		
-	-	-
-	-	-

PAGE 2/3	ISSUE 28-06-17B	SERIES NEX10	PART NUMBER R180252007
----------	-----------------	--------------	-------------------------------

PACKAGING

Standard	Unit	Other
50	Contact us	Contact us

ELECTRICAL CHARACTERISTICS

Impedance	50	Ω
Frequency	0-20	GHz
VSWR	1.02* + 0.0200	x F(GHz) Maxi
Insertion loss	0.05	√F(GHz) dB Maxi
RF leakage	NA	- F(GHz)) dB Maxi
Voltage rating	500	Veff Maxi
Dielectric withstanding voltage	1500	Veff mini
Insulation resistance	5000	MΩ mini

MECHANICAL CHARACTERISTICS

Center contact retention		
Axial force – Mating End	NA	N mini
Axial force – Opposite end	NA	N mini
Torque	NA	N.cm mini
Recommended torque		
Mating	NA	N.cm
Panel nut	NA	N.cm
Clamp nut	NA	N.cm
A/F clamp nut	0.0000	mm
Mating life	100	Cycles mini
Weight	9.8000	g

ENVIRONMENTAL

Operating temperature	-55/+125	°C
Hermetic seal	NA	Atm.cm3/s
Panel leakage	NA	

SPECIFICATION

CABLE ASSEMBLY

Stripping	a	b	c	d	e	f
mm	3.2	0	0	0	0.85	0

Assembly instruction:

Recommended cable(s)

RG 402

Characteristics indicated on this data sheet are those that can be achieved with the highest performance cable. Intrinsic limitations of the cable may diminish the performance of the assembly

Cable retention

- pull off	200	N mini
- torque	NA	N.cm

TOOLING

Part Number	Description	Hexagon
.	.	.

OTHER CHARACTERISTICS

PIM3<=-123 dBm, 2 carriers of +43dBm

PAGE 3/3	ISSUE 28-06-17B	SERIES NEX10	PART NUMBER R180252007
----------	-----------------	--------------	------------------------

COMPONENTS

BODY

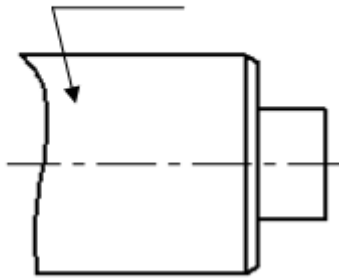

CENTER CONTACT

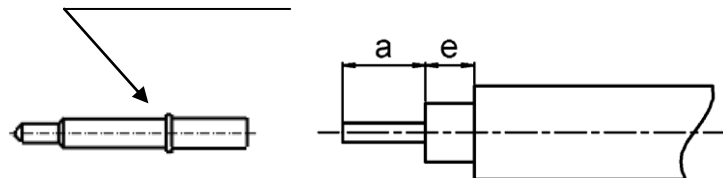

1

- Strip the cable with the cable stripping tool.
- Clean the cable

3

- Introduce the cable into the body until stop.
- Place the sub-assembly on assembly jig
- Solder body on the cable.
- Let assembly cool down before removing it from the jig.

2

- Insert center contact until the cable
- Solder center contact

