

## FlexInput IC for automotive applications



TQFP48 (7x7 mm)

### Features

- AEC-Q100 qualified 
- 12 V and 24 V systems compatible (operating battery supply voltage 5.5 V-36 V)
- Programmable interface with 15 total inputs:
  - 12 for connection to external analog loads (with connection to VVAR, VDD5 and clamped battery VPRES, with resistance measurement)
    - 4 with also  $\lambda$  sensor functionality
    - 4 with also SENT functionality
  - 3 for connection to external digital switches (with connection to VPRES)
- Programmable pull-up/down current sources
- Integrated precise resistance measurements
- 12 bit ADC for voltage measurements
- 15 bit ADC for resistance measurements
- Variable reluctance sensor / Hall sensor Interface
- 1 analog output channel + 4 digital output channels
- SPI interface for device configuration and data communication
- Overtemperature protection
- Thermal resistance  $R_{th(j-c)} = 3 \text{ K/W}$

### Description

The L9966 is an automotive grade IC designed to be used as sensors interface. Up to 15 channels are available for analog sensing, resistance measurement and digital sensing (e.g. temperature, lambda, pressure, position sensors).

The L9966 allows replacing a number of discrete components and it gives the possibility to change the sensors across different applications without modifying the PCB hardware.

Target applications are Engine Control Units and Body/Chassis Modules.

#### Product status link

[L9966](#)

#### Product summary

<b>Order code</b>	L9966CB-TR
<b>Package</b>	TQFP48
<b>Packing</b>	Tape and reel

# 1 Block diagram

Figure 1. Block diagram

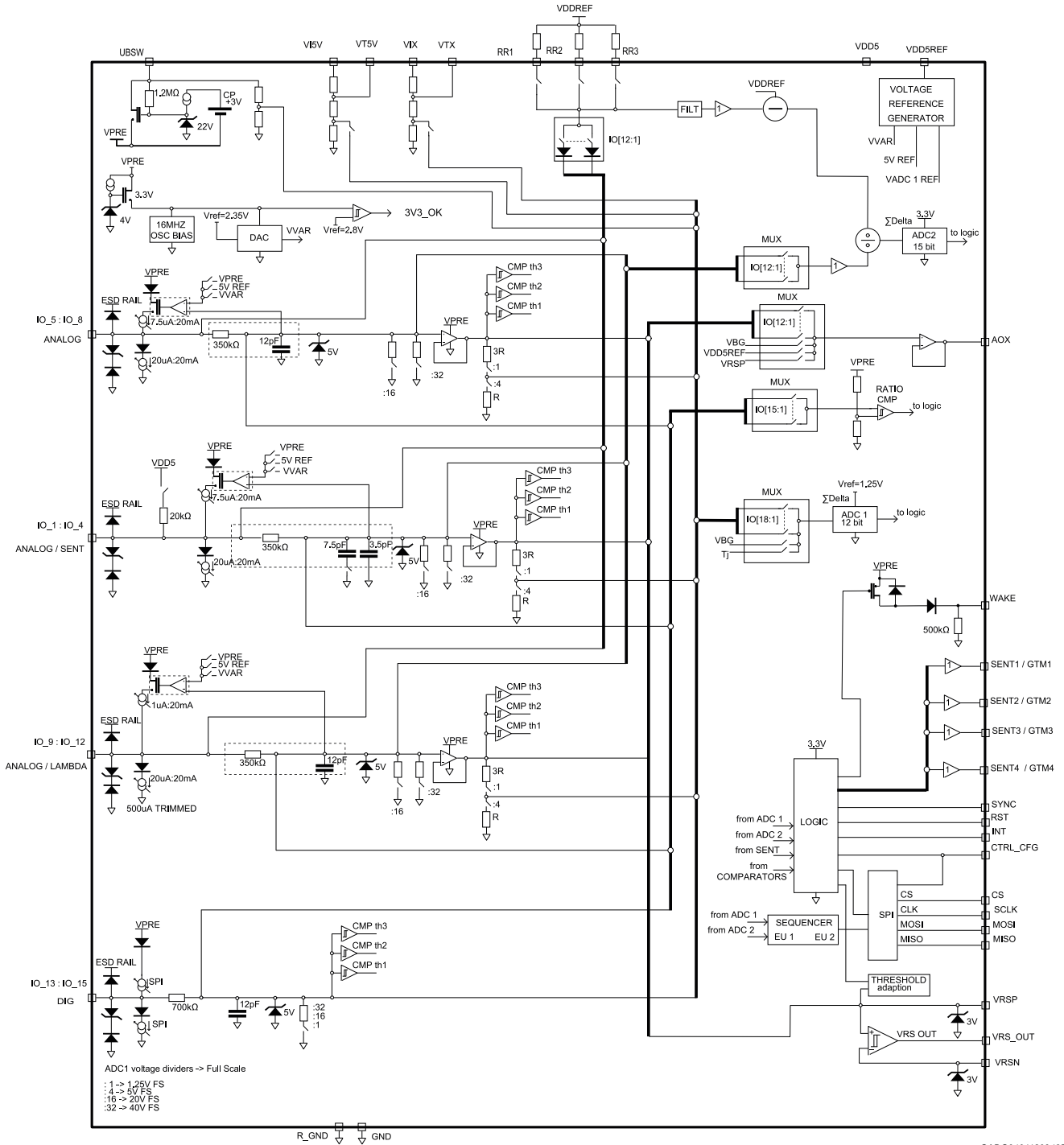

## 2 Pin description

Figure 2. Pin connection diagram

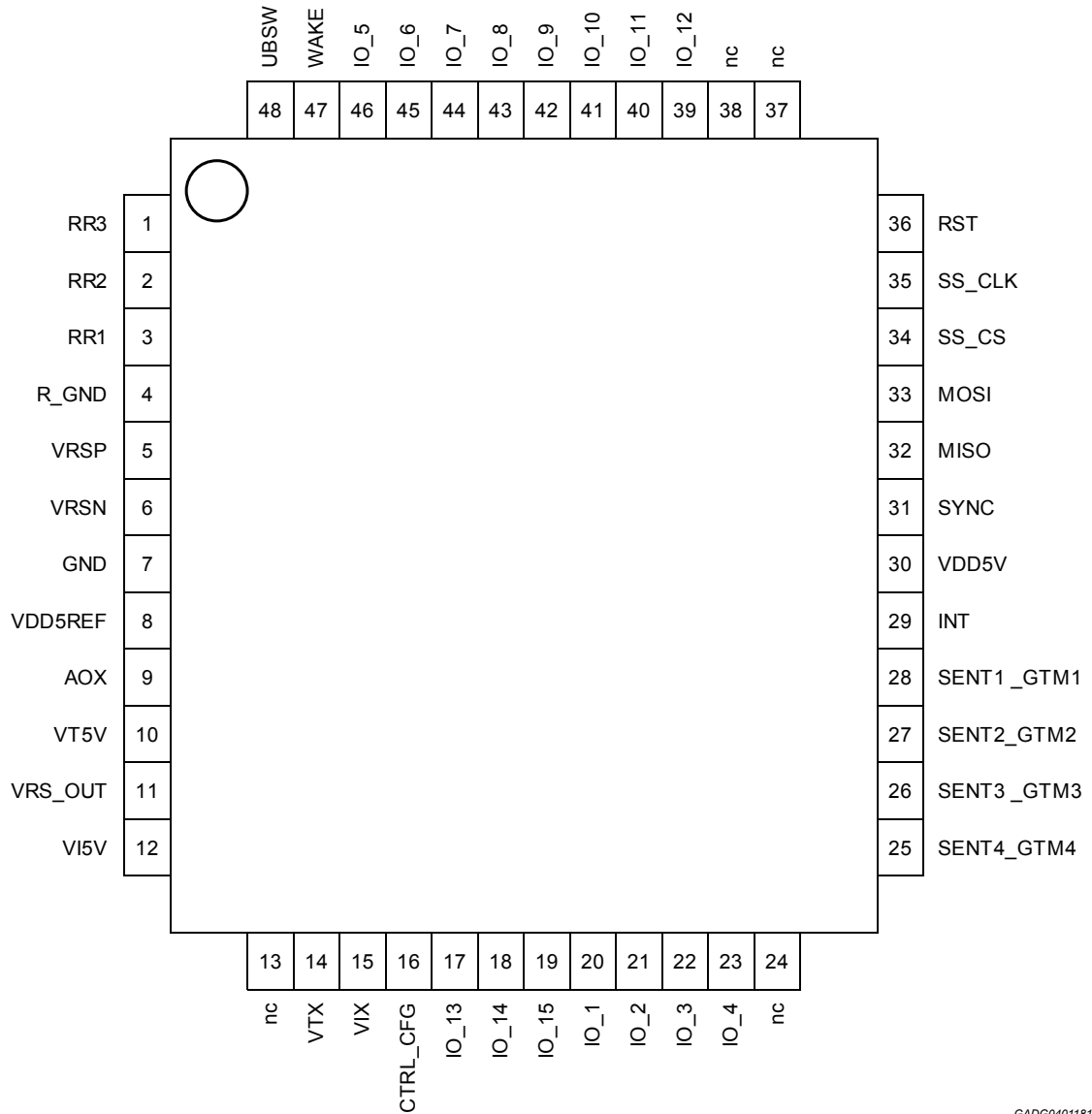

GADG0401181015PS

Table 1. Pin description

Pin-Nr.	Pin-name	Description	Pin-class <sup>(1)</sup>
1	RR3	Reference Pullup Resistor 3 for R-Measurement	I
2	RR2	Reference Pullup Resistor 2 for R-Measurement	I
3	RR1	Reference Pullup Resistor 1 for R-Measurement	I
4	R_GND <sup>(2)</sup>	Reference Ground for high accuracy signals	I
5	VRSP	Positive variable reluctance sensor input	A
6	VRSN	Negative variable reluctance sensor input	A

Pin-Nr.	Pin-name	Description	Pin-class <sup>(1)</sup>
7	GND	Ground for supply voltage	S
8	VDD5REF	Positive reference to both ADC	I
9	AOX	Analog output for input channel x	I
10	VT5V	Ratiometric Voltage output VI5V	I
11	VRS_Out	Digital Output of Variable reluctance sensor	I
12	VI5V	Input Voltage	I
13	nc	Not connected	-
14	VTX	Ratiometric Voltage output VIX	I
15	VIX	Input Voltage	I
16	CTRL_CFG	Input to control current source / Configuration input to select SPI Address-Mux during Reset	I
17	IO_13	Flexible Input and current output 13	D
18	IO_14	Flexible Input and current output 14	D
19	IO_15	Flexible Input and current output 15	D
20	IO_1	Flexible Input and current output 1 / SENT1	A
21	IO_2	Flexible Input and current output 2 / SENT2	A
22	IO_3	Flexible Input and current output 3 / SENT3	A
23	IO_4	Flexible Input and current output 4 / SENT4	A
24	nc	Not connected	-
25	SENT4_GTM4	Digital Output for SENT 4 channel / GTM_TO_SENT_4	I
26	SENT3_GTM3	Digital Output for SENT 3 channel r/ GTM_TO_SENT_3	I
27	SENT2_GTM2	Digital Output for SENT 2 channel / GTM_TO_SENT_2	I
28	SENT1_GTM1	Digital Output for SENT 1 channel / GTM_TO_SENT_1	I
29	INT	Interrupt (result status for controller)	I
30	VDD5V	5 V Power supply	I
31	SYNC	Digital input to synchronize sequencer start	I
32	MISO	Communication interface clock for Master-IN/ Slave-OUT	I
33	MOSI	Communication interface for Master-OUT/ Slave-IN	I
34	CS	Communication interface chip select	I
35	SCLK	Communication interface clock	I
36	RST	Reset	I
37	nc	Not connected	-
38	nc	Not connected	-
39	IO_12	Flexible Input and current output 12 / LAMBDA	A
40	IO_11	Flexible Input and current output 11 / LAMBDA	A
41	IO_10	Flexible Input and current output 10 / LAMBDA	A
42	IO_9	Flexible Input and current output 9 / LAMBDA	A
43	IO_8	Flexible Input and current output 8	A
44	IO_7	Flexible Input and current output 7	A
45	IO_6	Flexible Input and current output 6	A
46	IO_5	Flexible Input and current output 5	A

Pin-Nr.	Pin-name	Description	Pin-class <sup>(1)</sup>
47	WAKE	Output for wake-up	I
48	UBSW	Battery supply	S

1. see **Pin-class legend**:

2. *R\_GND is the ground reference for ADC1, ADC2, VDD5REF voltage divider, input channel voltage dividers. In case R\_GND connection to ground on the PCB is lost, R\_GND is referenced one diode voltage drop above GND.*

**Pin-class legend:**

- I:** ECU Internal Pins: connection to other electrical components on the ECU (Local pins).
- S:** Supply Pins: connection to supply sources with protected battery supply (Local pins except UBSW that is a global pin).
- A:** Analog Inputs: connection to external ECU pins (Global pin).
- D:** Digital Inputs: connection to external ECU pins (Global pin).

### 3 Package information

In order to meet environmental requirements, ST offers these devices in different grades of **ECOPACK®** packages, depending on their level of environmental compliance. ECOPACK® specifications, grade definitions and product status are available at: [www.st.com](http://www.st.com). ECOPACK® is an ST trademark.

#### 3.1 TQFP48 (7x7x1 mm exposed pad down) package information

Figure 3. TQFP48 (7x7x1 mm exposed pad down) package outline

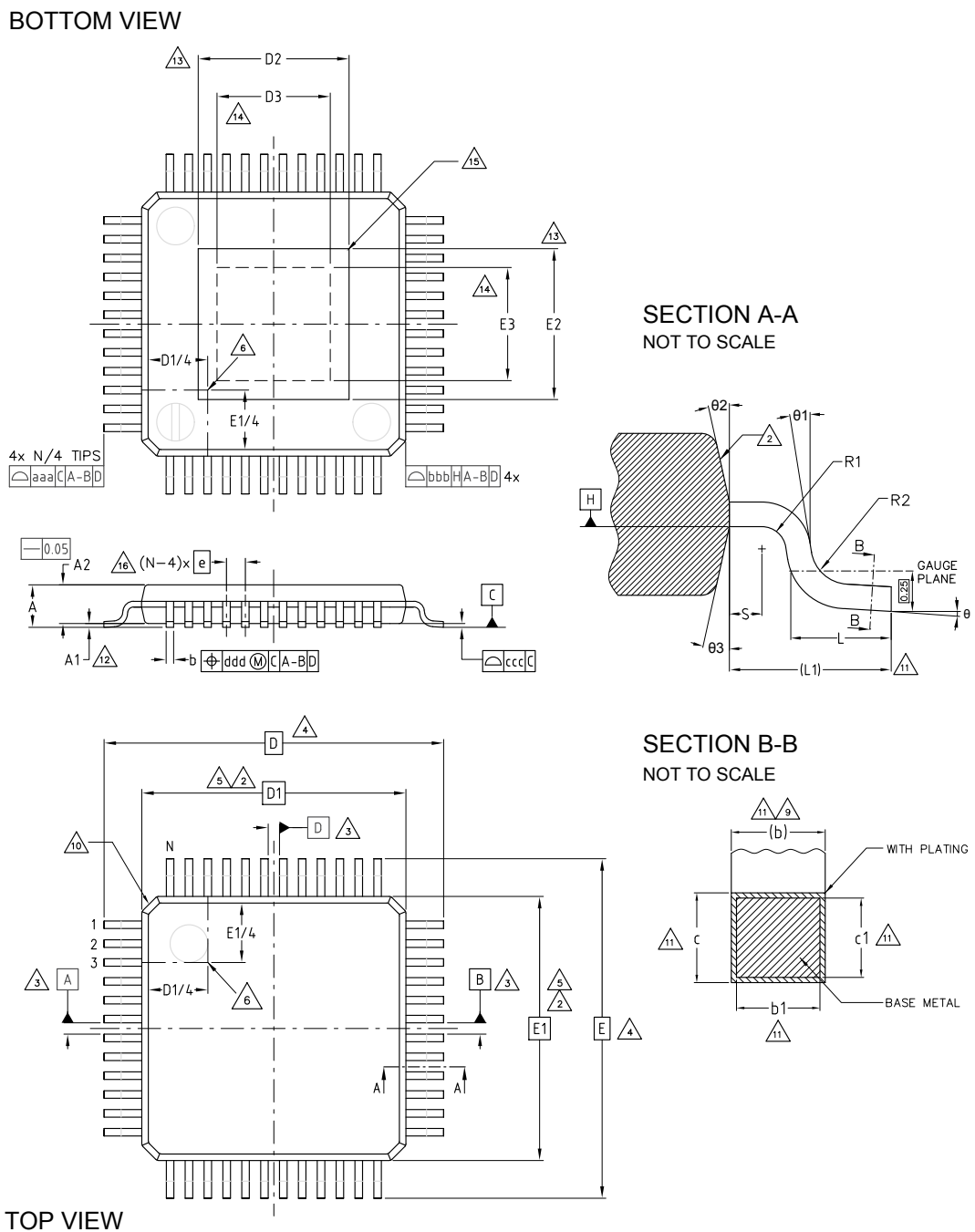

**Table 2. TQFP48 (7x7x1 mm exp. pad down) package mechanical data**

Symbol	Dimensions			Note
	Min.	Typ.	Max.	
Θ	0°	3.5°	7°	
Θ1	0°	-	-	
Θ2	11°	12°	13°	
Θ3	11°	12°	13°	
A	-	-	1.20	15
A1	0.05	-	0.15	12
A2	0.95	1.00	1.05	15
b	0.17	0.22	0.27	9, 11
b1	0.17	0.20	0.23	11
c	0.09	-	0.20	11
c1	0.09	-	0.16	11
D	9.00 BSC			4
D1	7.00 BSC			2, 5
D2	-	-	4.15	13
D3	3.89	-	-	14
e	0.50 BSC			
E	9.00 BSC			4
E1	7.00 BSC			2, 5
E2	-	-	4.15	13
E3	3.89	-	-	14
L	0.45	0.60	0.75	
L1	1.00 REF			
N	48			16
R1	0.08	-	-	
R2	0.08	-	0.20	
S	0.20	-	-	
<b>Tolerance of form and position</b>				
aaa	0.20			1, 7
bbb	0.20			
ccc	0.08			
ddd	0.08			

**Notes:**

1. Dimensioning and tolerancing schemes conform to ASME Y14.5M-1994.
2. The top package body size may be smaller than the bottom package size up to 0.15 mm.
3. Datum A-B and D to be determined at datum plane H.
4. To be determined at seating datum plane C.
5. Dimensions D1 and E1 do not include mold flash or protrusions. Allowable mold flash or protrusions is "0.25 mm" per side. D1 and E1 are maximum plastic body size dimensions including mold mismatch.

6. Details of pin 1 identifier are optional but must be located within the zone indicated.
7. All dimensions are in millimeters.
8. No intrusion allowed inwards the leads.
9. Dimension "b" does not include dambar protrusion. Allowable dambar protrusion shall not cause the lead width to exceed the maximum "b" dimension by more than 0.08 mm. Dambar cannot be located on the lower radius or the foot. Minimum space between protrusion and an adjacent lead is 0.07 mm for 0.4 mm and 0.5 mm pitch packages.
10. Exact shape of each corner is optional.
11. These dimensions apply to the flat section of the lead between 0.10 mm and 0.25 mm from the lead tip.
12. A1 is defined as the distance from the seating plane to the lowest point on the package body.
13. Dimensions D2 and E2 show the maximum exposed metal area on the package surface where the exposed pad is located (if present). It includes all metal protrusions from exposed pad itself.
14. Dimensions D3 and E3 show the minimum solderable area, defined as the portion of exposed pad which is guaranteed to be free from resin flashes/bleeds, bordered by internal edge of inner groove.
15. The optional exposed pad is generally coincident with the top or bottom side of the package and not allowed to protrude beyond that surface.
16. "N" is the number of terminal positions for the specified body size.



## Revision history

**Table 3. Document revision history**

Date	Version	Changes
22-Nov-2018	1	Initial release.

## Contents

<b>1</b>	<b>Block diagram</b> .....	<b>2</b>
<b>2</b>	<b>Pin description</b> .....	<b>3</b>
<b>3</b>	<b>Package information</b> .....	<b>6</b>
<b>3.1</b>	<b>TQFP48 (7x7x1 mm exposed pad down) package information</b> .....	<b>6</b>
	<b>Revision history</b> .....	<b>9</b>

**IMPORTANT NOTICE – PLEASE READ CAREFULLY**

STMicroelectronics NV and its subsidiaries (“ST”) reserve the right to make changes, corrections, enhancements, modifications, and improvements to ST products and/or to this document at any time without notice. Purchasers should obtain the latest relevant information on ST products before placing orders. ST products are sold pursuant to ST’s terms and conditions of sale in place at the time of order acknowledgement.

Purchasers are solely responsible for the choice, selection, and use of ST products and ST assumes no liability for application assistance or the design of Purchasers’ products.

No license, express or implied, to any intellectual property right is granted by ST herein.

Resale of ST products with provisions different from the information set forth herein shall void any warranty granted by ST for such product.

ST and the ST logo are trademarks of ST. All other product or service names are the property of their respective owners.

Information in this document supersedes and replaces information previously supplied in any prior versions of this document.

© 2018 STMicroelectronics – All rights reserved