

# Development Board EPC9064 Quick Start Guide

*EPC2108*

*60 V Half Bridge with Sync FET Bootstrap Gate Drive  
Configurable as Buck Converter or ZVS Class-D Amplifier*

Revision 1.0



## DESCRIPTION

The EPC9064 development board is a 60 V maximum device voltage, 1.5 A maximum output current, half bridge with onboard gate drives, featuring the EPC2108 enhancement mode (eGaN®) half bridge. The gate driver has been configured with a synchronous FET bootstrap circuit included in the EPC2108 device that eliminates high side device losses induced by the reverse recovery losses of the internal bootstrap diode of the gate driver. The purpose of this development board is to simplify the evaluation process of the EPC2108 eGaN half bridge by including all the critical components on a single board that can be easily connected into any existing converter. The inclusion of the synchronous FET bootstrap circuit enables significant increase in operating frequency capability of the half bridge circuit.

The EPC9064 development board is 2" x 1.5" and has one EPC2108 eGaN device in a half bridge configuration using Texas Instruments LM5113 gate driver with supply and bypass capacitors. The board contains all critical components and layout for optimal switching performance. There are also various probe points to facilitate simple waveform measurement and efficiency calculation. The board includes pads for the inclusion of customer components to facilitate testing in a Buck converter or ZVS Class D amplifier configurations. A complete block diagram of the circuit is given in figure 1.

For more information on the EPC2108 eGaN half bridge please refer to the datasheet available from EPC at [www.epc-co.com](http://www.epc-co.com). The datasheet should be read in conjunction with this quick start guide.

## QUICK START PROCEDURE

Development board EPC9064 is easy to set up to evaluate the performance of the EPC2108 eGaN half bridge. Refer to figure 2 for proper connect and measurement setup and follow the procedure below:

1. Configure the board for either ZVS class D (L<sub>ZVS</sub> and J2) operation OR Buck converter (L<sub>buck</sub>) operation.
2. With power off, connect the input power supply bus to +V<sub>IN</sub> (J1) and ground / return to -V<sub>IN</sub> (J4).
3. For ZVS class D operation, with power off, connect a HF load to the HF output (RF-J2 OR V<sub>SW</sub>-J3 and GND-J4). For Buck converter operation, with power off, connect a DC load to the DC output (+V<sub>OUT</sub>-J5 and GND-J4).

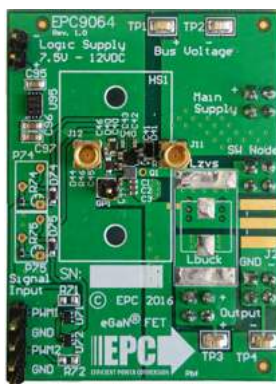

EPC9064 development board photo.

Table 1: Performance Summary (T<sub>A</sub> = 25°C) EPC9064

Symbol	Parameter	Conditions	Min	Max	Units
V <sub>DD</sub>	Gate Drive Input Supply Range		7.5	12	V
V <sub>IN</sub>	Bus Input Voltage Range			48*	V
V <sub>OUT</sub>	Switch Node Output Voltage			60	V
I <sub>OUT</sub>	Switch Node Output Current			1.5*	A
V <sub>PWM</sub>	PWM Logic Input Voltage Threshold	Input 'High' Input 'Low'	3.5 0	6 1.5	V V
	Minimum 'High' State Input Pulse Width	V <sub>PWM</sub> rise and fall time < 10ns	40		ns
	Minimum 'Low' State Input Pulse Width	V <sub>PWM</sub> rise and fall time < 10ns	160#		ns

\*Assumes inductive load, maximum current depends on die temperature – actual maximum current will be subject to switching frequency, bus voltage and thermals.

# Limited by time needed to 'refresh' high side bootstrap supply voltage.

4. With power off, connect the gate drive input to +V<sub>DD</sub> (J90, Pin-1) and ground return to -V<sub>DD</sub> (J90, Pin-2).
5. With power off, connect the input PWM control signal to PWM (J70, Pin-1) and ground return to either Pin-2 or Pin-4 of J70.
6. Turn on the gate drive supply – make sure the supply is within the 7.5V and 12V range.
7. Turn on the controller / PWM input source.
8. Turn on the bus voltage, starting at 0 V and slowly increasing to the required value (do not exceed the absolute maximum voltage of 48V on V<sub>OUT</sub>) and probe switching node to observe switching operation.
9. Once operational, adjust the bus voltage and load PWM control within the operating range and observe the output switching behavior, efficiency and other parameters.
10. For shutdown, please follow steps in reverse.

**NOTE.** When measuring the high frequency content switch node, care must be taken to avoid long ground leads. Measure the switch node by placing the oscilloscope probe tip through the large via on the switch node (designed for this purpose) and grounding the probe directly across the GND terminal provided. See figure 3 for proper scope probe technique.

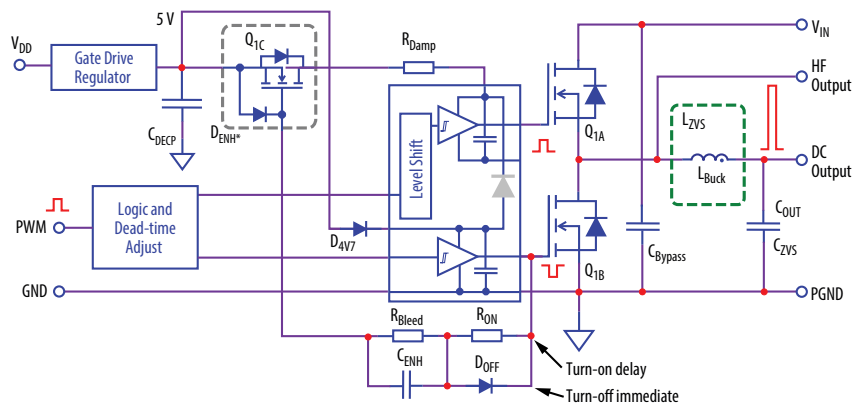

Figure 1: Block diagram of EPC9064 development board.

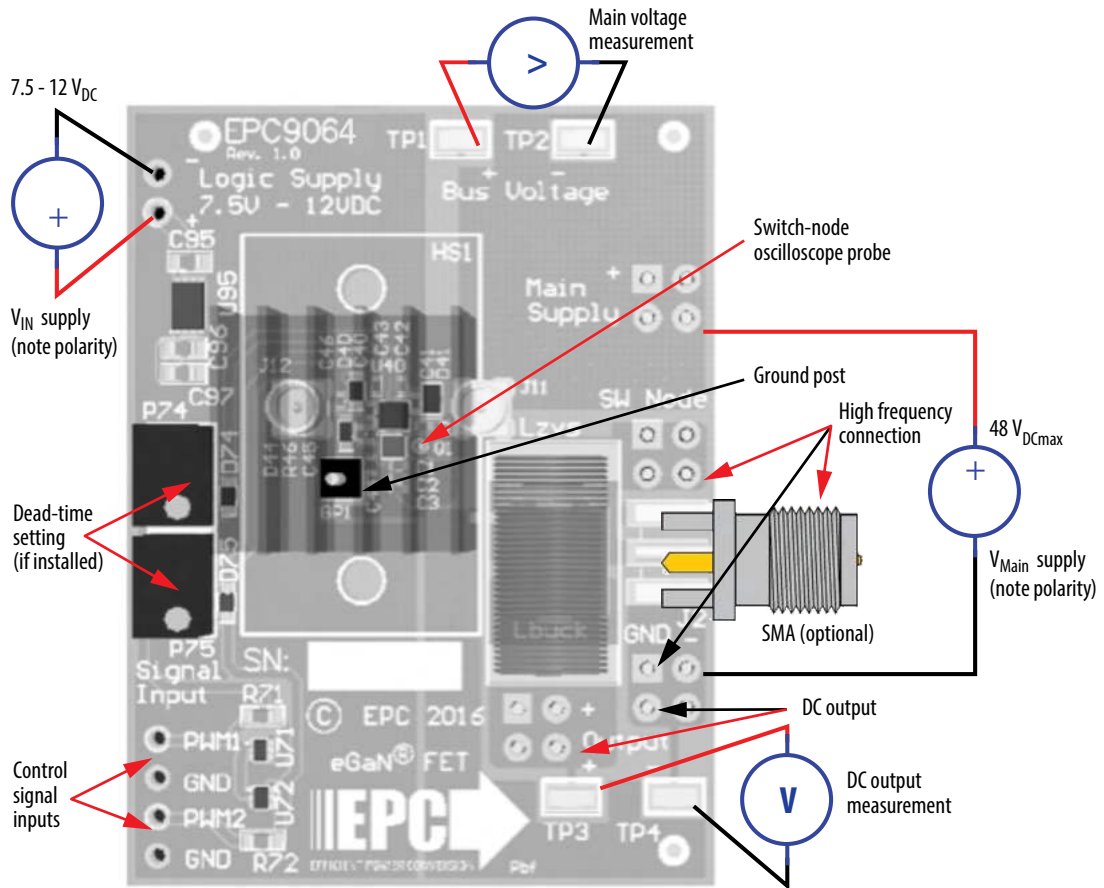

Figure 2: Proper connection and measurement setup.

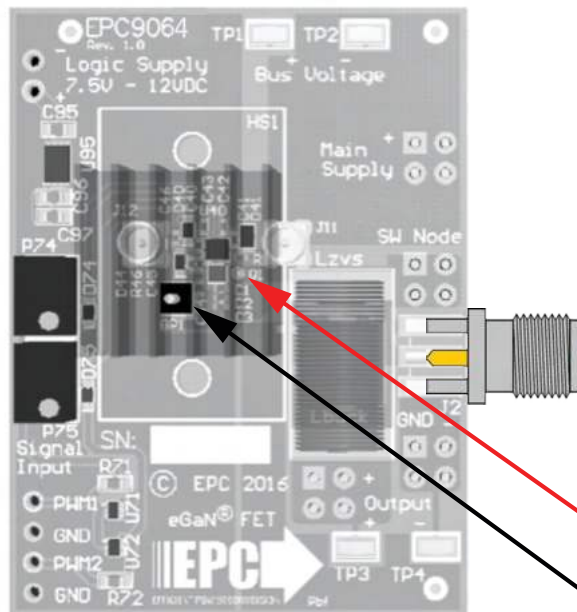

Figure 3: Proper measurement of the switch nodes.

### MEASUREMENT CONSIDERATIONS

The EPC9064 development board has been provided with specially designed high frequency (up to 1 GHz minimum) capable measurement connections using MMCX connectors located at J11 & J12 with direct access to the gate signals of both the upper and lower FETs. These nodes can be measured directly using the Tektronix IsoVu probe shown in figure 4. Figure 5 shows typical gate waveforms measured using the IsoVu probe.



Figure 4: Tektronix IsoVu measurement setup.

This native connection between the high and low side gate-source nodes to an IsoVu probe tip cable has less than 2 pF common mode loading and completely eliminates ground loops due to its galvanic isolation. These MMCX connectors offer a shielded coaxial environment to the test point which minimizes noise pickup.

Please contact EPC for special instructions on using these connections. To prevent an unterminated transmission line hanging on the gate it is recommended to remove resistors R1 & R2 when not using this feature. The maximum impedance loading of these nodes is 2.5 kΩ.

Tektronix is a leading manufacturer of power test solutions for design validation, characterization, and performance testing. EPC partnered with Tektronix to define the requirements for accurate measurements on GaN devices which led to the development of the Tektronix IsoVu measurement system. IsoVu is a galvanically isolated differential measurement system with 1 GHz bandwidth, 1 Million to 1 (120 dB) common mode rejection ratio, 50 V differential, and 2000 V common mode voltage range. Previously impossible differential measurements such as the high-side  $V_{GS}$  are now possible because of IsoVu's high common mode rejection across bandwidth.

IsoVu allows you to:

- Characterize the time alignment of high side and low side events
- Optimize and tune switching characteristics such as edge rates, overshoot, ringing and dead time
- See the interactions due to parasitic coupling between the high and low side transistors
- Make isolated high frequency current measurements using low impedance sense resistors
- Improve reliability through accurate characterization across all operating conditions

EPC would like to acknowledge Tektronix (<http://www.tek.com/isolated-measurement-systems>) for their support of this project.

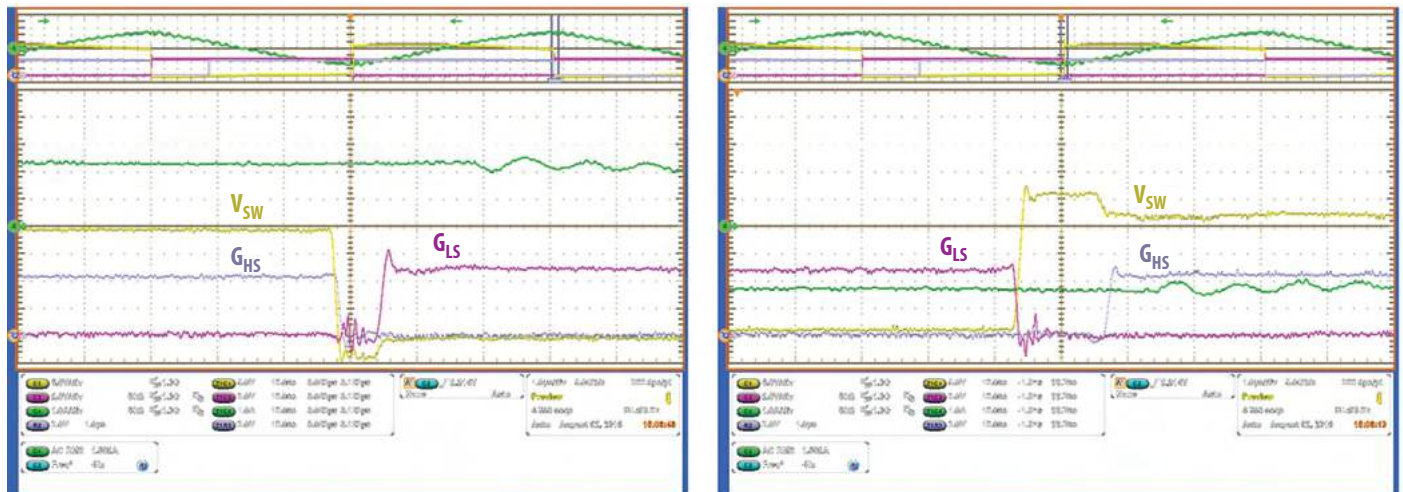

Figure 5: Upper gate and lower gate measurements using the Tektronix IsoVu and switch-node voltage measurement using the TPP1000 probe.

### THERMAL CONSIDERATIONS

The EPC9064 development board showcases the EPC2108 eGaN half bridge with integrated synchronous bootstrap. Although the electrical performance surpasses that for traditional silicon devices, their relatively smaller size does magnify the thermal management requirements. The EPC9064 is intended for bench evaluation with low ambient temperature and convection cooling. The addition of heat-sinking and forced air cooling can significantly increase the current rating of these devices, but care must be taken to not exceed the absolute maximum die temperature of 150°C. A heatsink kit can be used with this board and the assembly is shown in figure 6. Contact EPC for more information on the heatsink kit.

**NOTE.** The EPC9064 development board does not have any current or thermal protection on board.

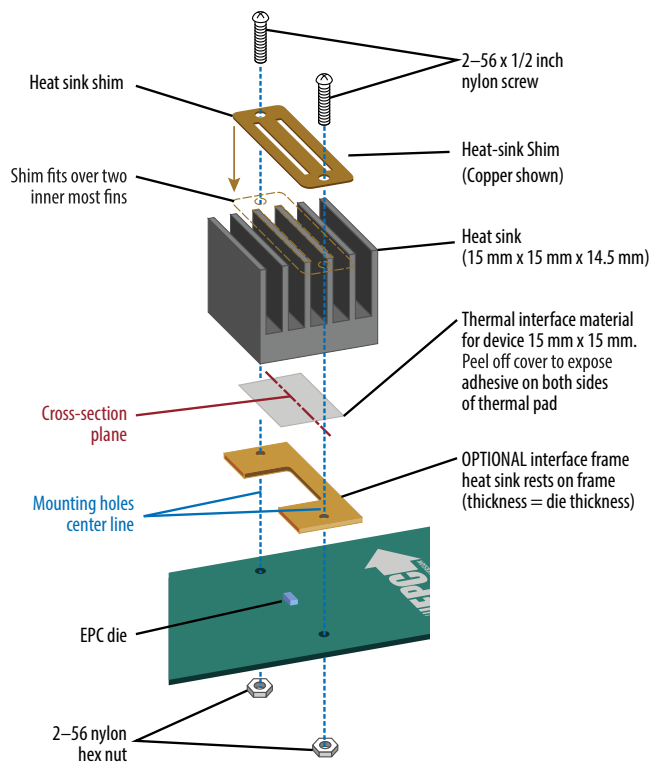

Figure 6: Assembly of the heatsink kit.

Table 2: EPC9064 Board

Item	Qty	Reference	Part Description	Manufacturer	Part Number
1	3	C1, C2, C3	10 nF, 100 V	TDK	C1005X7S2A103K050BB
2	3	C4, C5, C6	1 μF 100 V	TDK	C2012X7S2A105K125AB
3	1	C7	1 μF 100 V	TDK	C2012X7S2A105K125AB
4	1	C40	4.7 μF, 10 V	Samsung	CL05A475MP5NRNC
5	3	C41, C44, C46	100 nF, 25 V	TDK	C1005X7R1E104K050BB
6	2	C42, C43	22 pF, 50 V	Kemet	C0402C220J5GACTU
7	1	C45	22 nF, 25 V	TDK	C1005X7R1E223K050BB
8	2	C71, C72	100 nF, 25 V	TDK	C1608X7R1E104K
9	3	C95, C96, C97	1 μF, 25 V	TDK	C1608X7R1E105K
10	1	D40	40 V 300 mA	ST	BAT54KFILM
11	1	D41	5 V1, 150 mW	Bournes	CD0603-Z5V1
12	2	D44, D45	40 V 30 mA	Diodes Inc.	SDM03U40-7
13	2	D74, D75	40 V 30 mA	Diodes Inc.	SDM03U40
14	1	GP1	.1" Male Vert. 1 pos	Würth	61300111121
15	4	J1, J3, J4, J5	2x2 .1" Male Vert.	TE Connectivity	5-146256-2
16	1	J70	.1" Male Vert. 4 pos	Tyco	4-103185-0-04
17	1	J90	.1" Male Vert. 2 pos	Würth	61300211121
18	1	Q1	60 V 240 mΩ with SB	EPC	EPC2108
19	2	R1, R2	0 Ω	Stackpole	RMCF0402ZT0R00
20	1	R44	4 Ω7	Panasonic	ERJ-2GEJ4R7X

Table 2: EPC9064 Board cont.

Item	Qty	Reference	Part Description	Manufacturer	Part Number
21	1	R45	20 $\Omega$	Stackpole	RMCF0402JT20R0
22	1	R46	27 k	Panasonic	ERJ-2GEJ273X
23	1	R70	10 k	Yageo	RC0603JR-0710KL
24	1	R74	430 $\Omega$	Panasonic	ERJ-2RKF4300X
25	1	R75	180 $\Omega$	Panasonic	ERJ-2RKF1800X
26	4	TP1, TP2, TP3, TP4	SMD probe loop	Keystone	5015
27	1	U40	100 V eGaN driver	Texas Instruments	LM5113TM or LMG1205
28	1	U71	2 In AND	Fairchild	NC7SZ08L6X
29	1	U72	2 In NAND	Fairchild	NC7SZ00L6X
30	1	U95	5.0 V 250 mA DFN	Microchip	MCP1703T-5002E/MC

## Optional Components

Item	Qty	Reference	Part Description	Part Description	Part Number
1	1	J2	SMA Board Edge	Linx	CONREVSMA013.062
2	2	J11, J12	MMCX SMD	Molex	0734152063
3	1	Lbuck	example 10 $\mu$ H, 3.5 A	Würth	744314101
4	1	Lzvs	example 500 nH	CoilCraft	2929SQ-501JEB
5	2	P74, P75	1 k	Murata	PV37W102C01B00
6	3	R71, R72, R73	0 $\Omega$	Panasonic	ERJ-3GEY0R00V

## Heatsink Kit

Item	Qty	Part Description	Manufacturer	Part Number
1	2	Screw Mach Phil 2-56 x 1/2 Nylon	B&F Fastener Supply	NY PMS 256 0050 PH
2	1	Heatsink mounting shim	Custom - Request from EPC	PCBshim
3	1	Heat-sink 15mm x 15mm x 14.5mm	Advanced Thermal Sol	ATS-54150K-C2-R0
4	1	Thermal interface pad with adhesive	Wakefield	173-7-1212A
5	2	Nylon washer	Keystone Electronics	3347
6	2	Washer Flat #2 Stainless Steel	B&F Fastener Supply	FWSS 002
7	2	Washer internal tooth #2 Stainless Steel	B&F Fastener Supply	INT LWSS 002
8	2	Hex Nut 3/16" 2-56 Stainless Steel	B&F Fastener Supply	HNSS256
8	2	Hex Nut 3/16" Nylon 2-56	B&F Fastner	NY HN 256

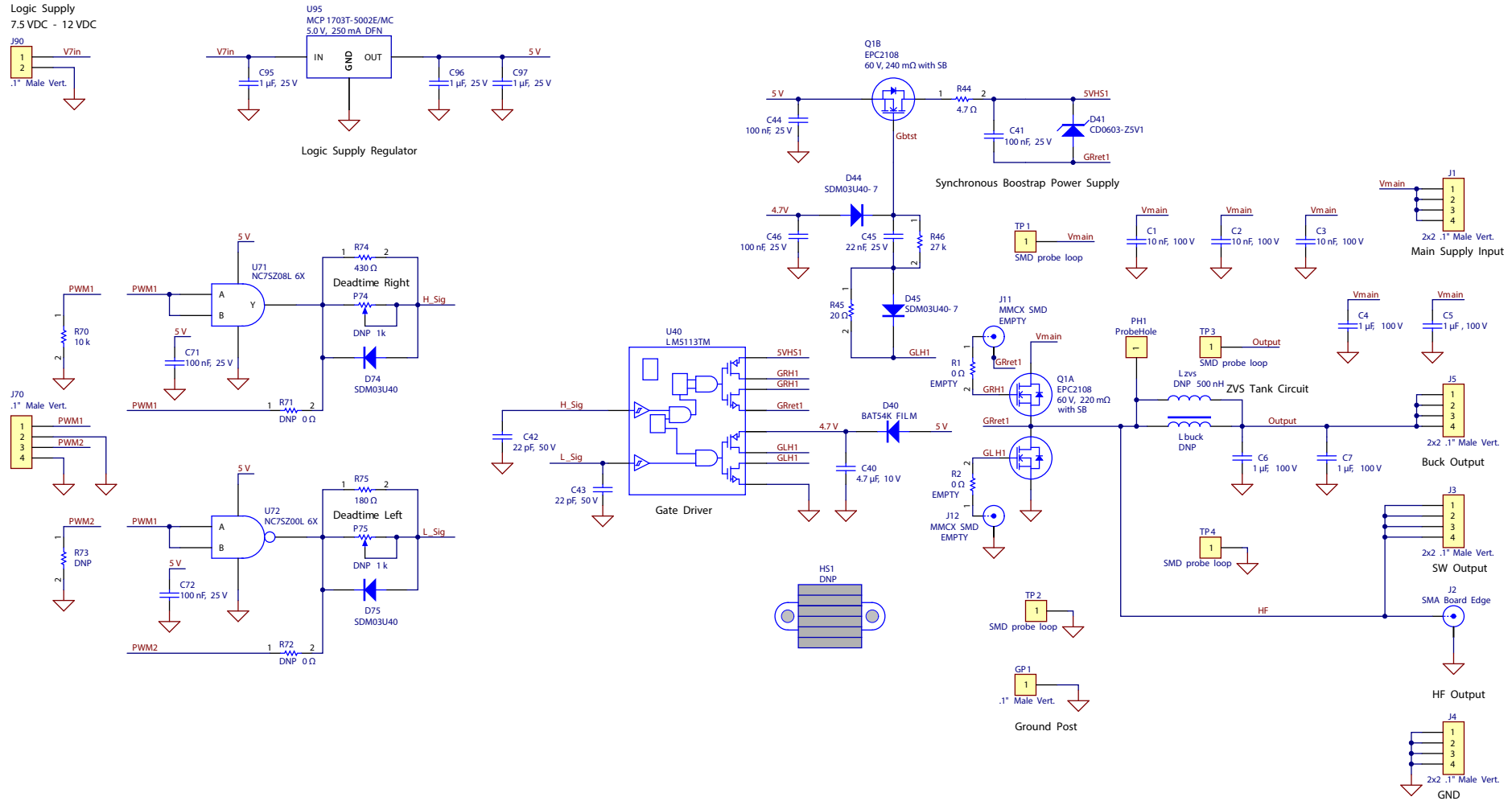

Figure 7: EPC9064 Schematic.

## For More Information:

Please contact [info@epc-co.com](mailto:info@epc-co.com)  
or your local sales representative

Visit our website:

[www.epc-co.com](http://www.epc-co.com)

Sign-up to receive  
EPC updates at  
[bit.ly/EPCupdates](http://bit.ly/EPCupdates)  
or text "EPC" to 22828



EPC Products are distributed through Digi-Key.

[www.digikey.com](http://www.digikey.com)

### Demonstration Board Warning and Disclaimer

The EPC9064 board is intended for product evaluation purposes only and is not intended for commercial use. Replace components on the Evaluation Board only with those parts shown on the parts list (or Bill of Materials) in the Quick Start Guide. Contact an authorized EPC representative with any questions.

This board is intended to be used by certified professionals, in a lab environment, following proper safety procedures. Use at your own risk.

As an evaluation tool, this board is not designed for compliance with the European Union directive on electromagnetic compatibility or any other such directives or regulations. As board builds are at times subject to product availability, it is possible that boards may contain components or assembly materials that are not RoHS compliant. Efficient Power Conversion Corporation (EPC) makes no guarantee that the purchased board is 100% RoHS compliant.

The Evaluation board (or kit) is for demonstration purposes only and neither the Board nor this Quick Start Guide constitute a sales contract or create any kind of warranty, whether express or implied, as to the applications or products involved.

Disclaimer: EPC reserves the right at any time, without notice, to make changes to any products described herein to improve reliability, function, or design. EPC does not assume any liability arising out of the application or use of any product or circuit described herein; neither does it convey any license under its patent rights, or other intellectual property whatsoever, nor the rights of others.