

MATERIALS AND FINISHES

SMA CONNECTOR

BODY BRASS
PLATED GOLD

CENTER CONTACT PHOSPHOR BRONZE
PLATED GOLD

INSULATOR TEFLON

JAM NUT BRASS
PLATED GOLD

LOCK WASHER SPCC
PLATED GOLD

UFL CONNECTOR

SHELL PHOSPHOR BRONZE
PLATED GOLD

HOUSING PBT

CENTER CONTACT PHOSPHOR BRONZE
PLATED GOLD

CABLE

1.13 CABLE OR EQUIVALENT
COLOR BLACK

SHRINK TUBE
VERSAFIT V2

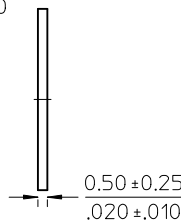
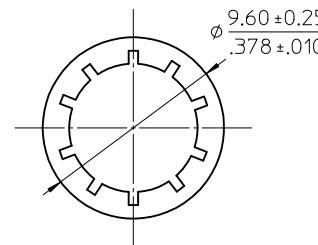
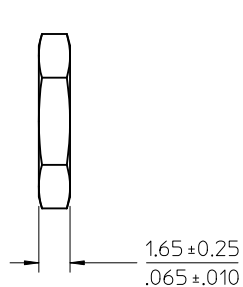
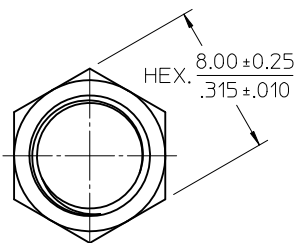
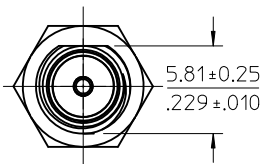
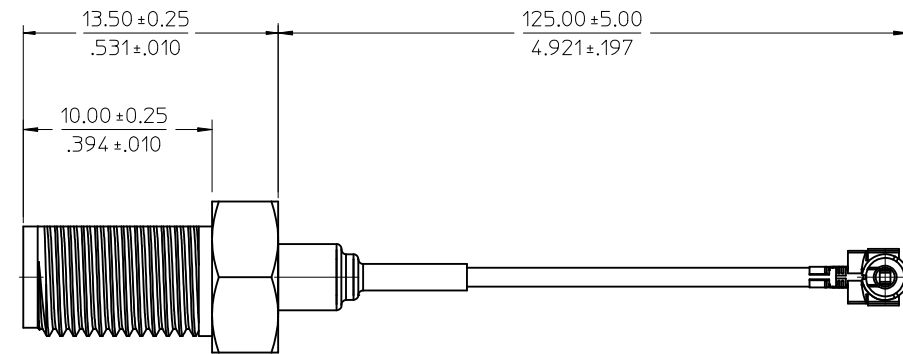
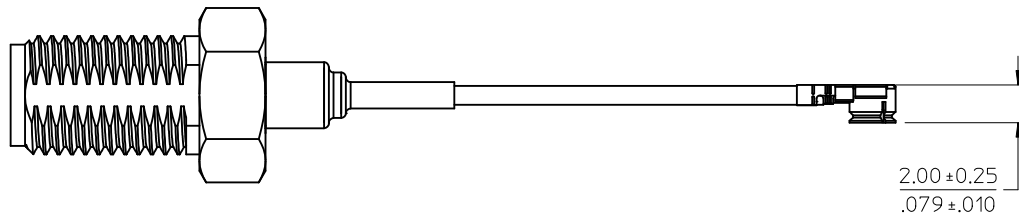
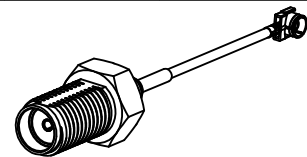

PART # 89761-4750

RTM PDR:1003525 EC NO: URF2010-0703 DRWNLIN 2010/03/23 CHKD:JOANNE 2010/03/23 APPR:MHUANG 2010/07/07 REV A	QUALITY SYMBOLS	GENERAL TOLERANCES (UNLESS SPECIFIED)	DIMENSION STYLE	SCALE	DESIGN UNITS	THIRD ANGLE PROJECTION	
	▽=0 ▽=0	mm INCH 4 PLACES ± --- ± --- 3 PLACES ± --- ± --- 2 PLACES ± --- ± --- 1 PLACE ± --- ± --- ANGULAR ± 2°	MM/IN	DRAWN BY DATE EL IN 2010/03/23 CHECKED BY DATE JOANNE 2010/03/23 APPROVED BY DATE MHUANG 2010/07/07	METRIC	MILEX MOLEX INCORPORATED	TITLE CABLE ASSY, SMA JACK STRIGHT TO 1.13 CABLE CA-SMA/J-UFL
		DRAFT WHERE APPLICABLE MUST REMAIN WITHIN DIMENSIONS	MATERIAL NO.	DOCUMENT NO.	SHEET NO.		
			897614750	SD-89761-475	1 OF 1		