

(2) POLARIZATION PEGS ARE SHOWN. HOWEVER, ASSEMBLIES MAY BE MANUFACTURED WITH (1) PEG ONLY

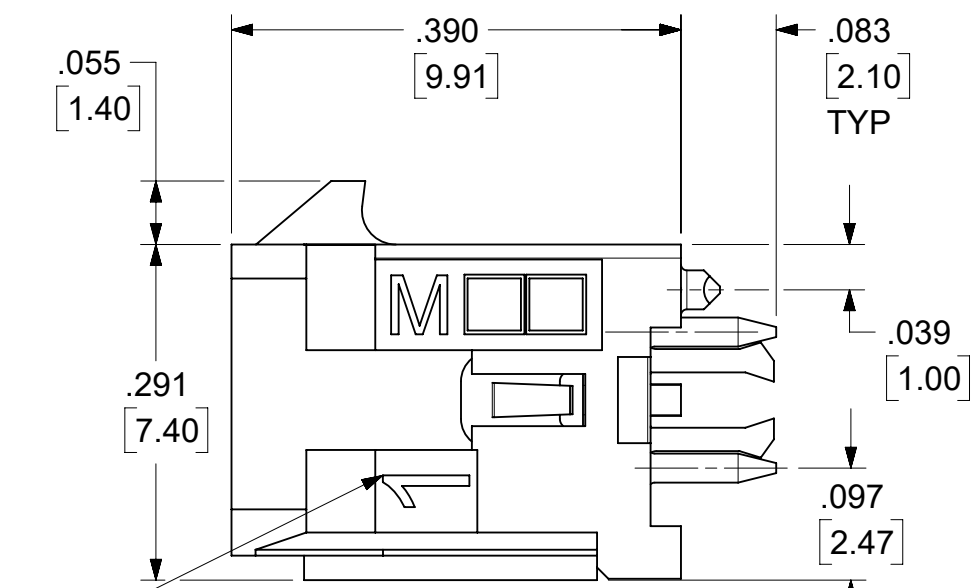

CIRCUIT "1" IDENTIFIED ON THIS SURFACE (APPROX. LOCATION SHOWN FOR REF.)

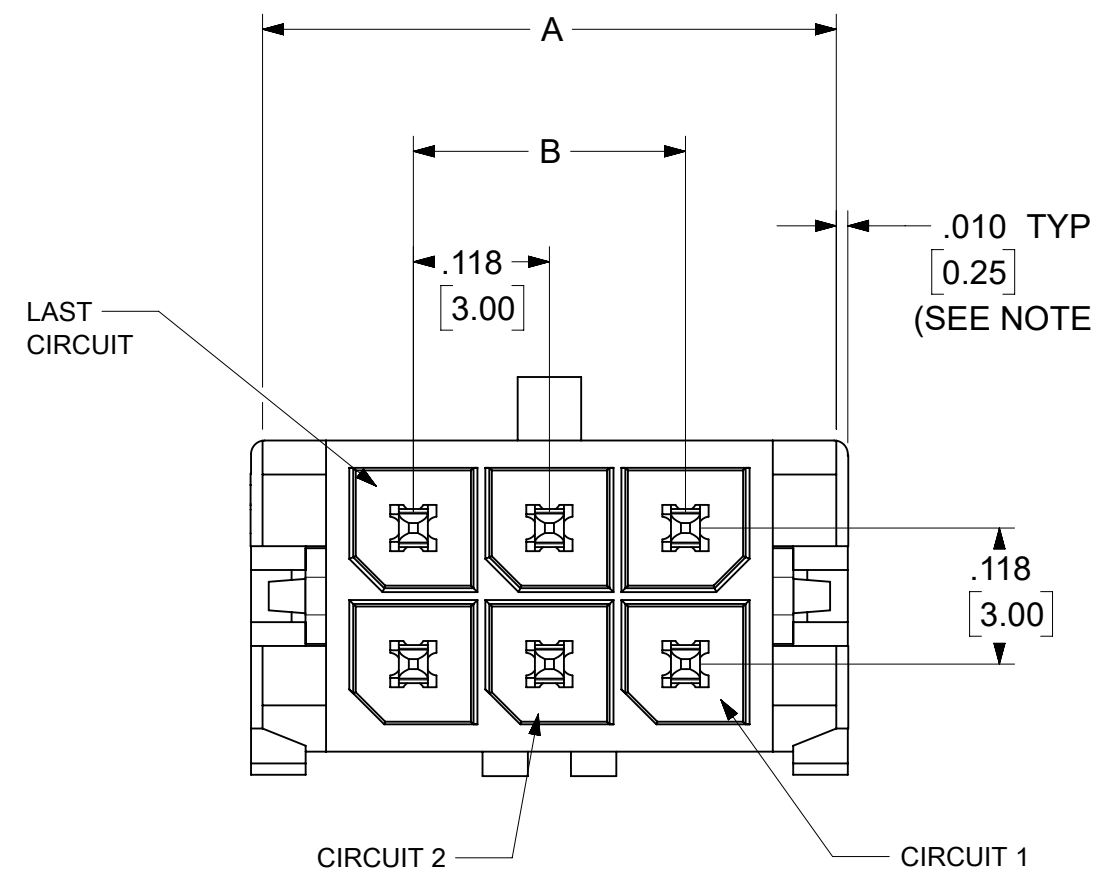
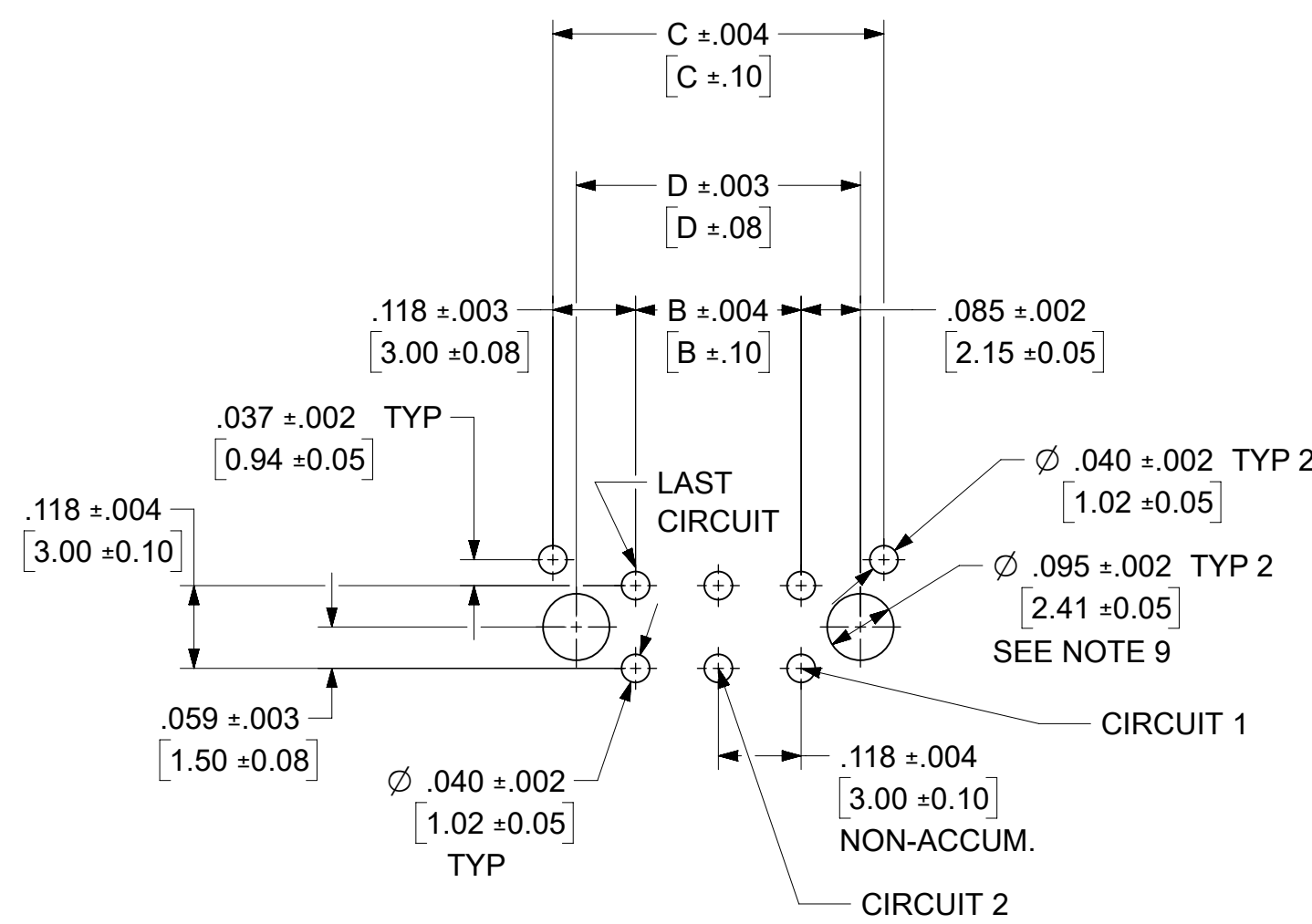

PCB LAYOUT: COMPONENT SIDE
RECOMMENDED PCB THICKNESS: .062/1.57

CKTS	A	B	C	D
02	.262 6.65	NA	.236 6.00	.169 4.30
04	.380 9.65	.118 3.00	.354 9.00	.287 7.30
06	.498 12.65	.236 6.00	.472 12.00	.405 10.30
08	.616 15.65	.354 9.00	.591 15.00	.524 13.30
10	.734 18.65	.472 12.00	.709 18.00	.642 16.30
12	.852 21.65	.591 15.00	.827 21.00	.760 19.30
14	.970 24.65	.709 18.00	.945 24.00	.878 22.30
16	1.088 27.65	.827 21.00	1.063 27.00	.996 25.30
18	1.206 30.65	.945 24.00	1.181 30.00	1.114 28.30
20	1.325 33.65	1.063 27.00	1.299 33.00	1.232 31.30
22	1.443 36.65	1.181 30.00	1.417 36.00	1.350 34.30
24	1.561 39.65	1.299 33.00	1.535 39.00	1.469 37.30

NOTES:

- HOUSING MATERIAL: GLASS FILLED LIQUID CRYSTAL POLYMER, UL94V-0, COLOR-BLACK
TERMINAL MATERIAL: BRASS ALLOY
- FINISH: A = .000060/(0.00152) MIN. REFLOW MATTE TIN OVER .000050/(0.00127) MIN. NICKEL PLATE. (FINISH IS BRIGHT IN APPEARANCE, THICKNESS AS APPLIED PRIOR TO REFLOW)
B = .000015/(0.00038) MIN. SELECT GOLD IN CONTACT AREA; .000100/(0.00254) MIN. SELECT MATTE TIN ON SOLDER TAILS; BOTH OVER .000050/(0.00127) MIN. NICKEL PLATE.
C = .000030/(0.00076) MIN. SELECT GOLD IN CONTACT AREA; .000100/(0.00254) MIN. SELECT MATTE TIN ON SOLDER TAILS; BOTH OVER .000050/(0.00127) MIN. NICKEL PLATE.
D = .000100/(0.00254) MIN. MATTE TIN OVER .000050/(0.00127) MIN. NICKEL PLATE.
- PRODUCT SPECIFICATION: PS-43045
- TRAY PACKAGED: SEE MOLEX DRAWING PK-70873-0314
- MATES WITH MICRO FIT (3.0) RECEPTACLE SERIES 43025
- CIRCUIT SIZES 2-6: "D" IS .265/6.74 FOR .010/0.25 STEP, CIRCUIT SIZES 8-24: "D" IS .063/1.60 FOR .010/0.25 STEP.
- THIS PART CONFORMS TO CLASS B REQUIREMENTS OF COSMETIC SPECIFICATION PS-45499-002.
- TEXT ON PART IS FOR REFERENCE ONLY. TEXT AND TEXT LOCATION MAY VARY DEPENDING ON PART NUMBER AND/OR TOOL.
- HOLES FOR CLIPS SHOULD BE PTH AND CLIPS SHOULD BE SOLDERED FOR BEST RETENTION TO PCB.

	FINISH A	FINISH B	FINISH C	FINISH D
CKTS	MATERIAL NO:	MATERIAL NO:	MATERIAL NO:	MATERIAL NO:
04				43045-0305
06				43045-0505
08				43045-0705
10				43045-0905
12				43045-1105
14				43045-1305
16				43045-1505
18				43045-1705
20				43045-1905
22				43045-2105
24				43045-2305
				43045-2505

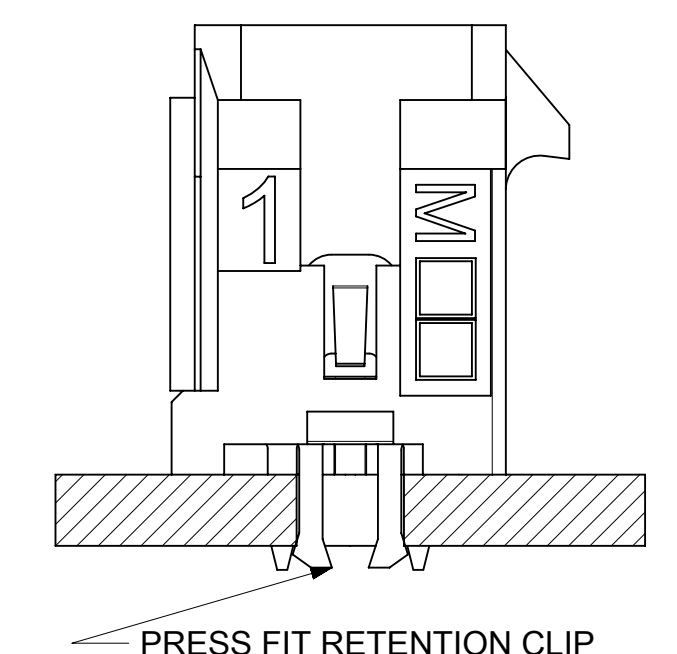

PRESS FIT RETENTION CLIP

FUNCTIONAL SYMBOLS FA = 0 FC = 0 FP = 0	THIS DRAWING CONTAINS INFORMATION THAT IS PROPRIETARY TO MOLEX ELECTRONIC TECHNOLOGIES, LLC AND SHOULD NOT BE USED WITHOUT WRITTEN PERMISSION		CURRENT REV DESC: REDRAWN, ADD NOTE 9	
	DIMENSION UNITS INCH/MM	SCALE NTS		
DIVISIONAL SYMBOLS 4 PLACES ± 3 PLACES ± 2 PLACES ± 1 PLACE ± 0 PLACES ±	GENERAL TOLERANCES (UNLESS SPECIFIED)		EC NO: 736143	
	MM	INCH	DRWN: SETHH6 2022/12/14	
	± 0.25	± 0.014	CHK'D: MKIPPER 2023/01/24	
	± 0.36	±	APPR: FSMITH 2023/01/26	
	±	±	INITIAL REVISION:	
	ANGULAR TOL ± 0.5°		DRWN: NNGUYEN 2014/01/24	
DRAFT WHERE APPLICABLE MUST REMAIN WITHIN DIMENSIONS	THIRD ANGLE PROJECTION	DRAWING	SERIES	MATERIAL NUMBER
		C-SIZE	43045	SEE CHART
DOCUMENT STATUS		P1	RELEASE DATE	2023/01/26 18:55:56
DOCUMENT NUMBER		DOC TYPE		DOC PART
SD-43045-041		PSD	001	A3
CUSTOMER		SHEET NUMBER		
GENERAL MARKET		1 OF 1		