



CertusPro-NX PCIe Bridge Board

Evaluation Board User Guide

FPGA-EB-02056-1.0

October 2022

Disclaimers

Lattice makes no warranty, representation, or guarantee regarding the accuracy of information contained in this document or the suitability of its products for any particular purpose. All information herein is provided AS IS, with all faults and associated risk the responsibility entirely of the Buyer. Buyer shall not rely on any data and performance specifications or parameters provided herein. Products sold by Lattice have been subject to limited testing and it is the Buyer's responsibility to independently determine the suitability of any products and to test and verify the same. No Lattice products should be used in conjunction with mission- or safety-critical or any other application in which the failure of Lattice's product could create a situation where personal injury, death, severe property or environmental damage may occur. The information provided in this document is proprietary to Lattice Semiconductor, and Lattice reserves the right to make any changes to the information in this document or to any products at any time without notice.

Contents

Acronyms in This Document.....	5
1. Introduction.....	6
1.1. CertusPro-NX PCIe Bridge Board.....	6
1.2. Features.....	7
1.3. CertusPro-NX Device.....	8
1.4. Applying Power to the Board.....	8
2. Jumper Definitions.....	9
3. Programming and I ² C.....	10
3.1. JTAG Download Interface.....	10
3.2. Alternate JTAG Download Interface.....	10
3.3. Other FPGA Configuration Pins.....	11
3.4. JTAG to MSPI Pass-through Interface.....	11
3.5. SPI Flash Device Selection in Programmer.....	11
4. CertusPro-NX Clock Sources.....	13
5. Power Scheme.....	14
6. Control Buses – I ² C, UART, and SPI.....	16
6.1. I ² C Topology.....	16
6.2. UART Topology.....	16
6.3. SPI Topology.....	16
7. LEDs and Switches.....	17
7.1. DIP Switch.....	17
7.2. Push Buttons.....	17
7.3. General Purpose LEDs.....	17
7.4. 7-Segment LED.....	18
8. Headers/Connectors and CertusPro-NX Device Ball Mapping.....	19
8.1. External Flash Configuration Header.....	19
8.2. PMOD Header.....	19
8.3. PCIe Edge Connector.....	20
8.4. HP_GPIO HEADER.....	20
8.5. Parallel FMC CFG Header.....	21
8.6. FMC Connector.....	21
8.7. USB Chip Connector.....	23
8.8. LPDDR4 Connections.....	25
9. Software Requirements.....	27
10. Storage and Handling.....	27
11. Ordering Information.....	27
Appendix A. CertusPro-NX PCIe Bridge Board Schematics.....	28
Appendix B. CertusPro-NX PCIe Bridge Board Bill of Materials.....	46
Technical Support Assistance.....	54
Revision History.....	55

Figures

Figure 1.1. Top View of CertusPro-NX PCIe Bridge Board.....	6
Figure 1.2. Bottom View of CertusPro-NX PCIe Bridge Board	7
Figure 1.3. 12 V DC Power Supply.....	8
Figure 2.1. Top View of CertusPro-NX PCIe Bridge Board – Jumper Selection	9
Figure 3.1. Configuration Architecture	10
Figure 3.2. SPI Flash Operation Dialog.....	12
Figure 4.1. Clock Scheme	13
Figure 5.1. Power Scheme	14
Figure A. 1. Cover Page	28
Figure A. 2. Block Diagram	29
Figure A. 3. SERDES QUADS, PCIe Edge	30
Figure A. 4. BANK5,6,1G SFP,DIP SW	31
Figure A. 5. BANK0,SPI FLASH,CONFIG_PIN	32
Figure A. 6. BANK2,BANK3, BANK4, GPIO Header	33
Figure A. 7. LPDDR4	34
Figure A. 8. BANK1,LEDS, 7 SEG DISPLAY	35
Figure A. 9. BANK7, PLL.....	36
Figure A. 10. ADC,VSS, VSSSDQ.....	37
Figure A. 11. FTDI High-Speed USB	38
Figure A. 12. FMC_HPC_SECTION	39
Figure A. 13. USB_3_CONTROLLER_SECTION_1	40
Figure A. 14. FPGA PWR, Power Supply Page1	41
Figure A. 15. Power Supply Page2	42
Figure A. 16. Power Supply Page3	43
Figure A. 17. CLOCK DIAGRAM	44
Figure A. 18. CLOCK DIAGRAM	45

Tables

Table 1.1. Board Power Supply	8
Table 2.1. Jumper Details.....	9
Table 3.1. JTAG Connection	10
Table 3.2. Other JTAG Signals	11
Table 4.1. Clock Sources	13
Table 5.1. VCCIO Supply Options	14
Table 5.2. Status LED Definition.....	15
Table 6.1. I ² C Bus Connections	16
Table 6.2. UART Bus Connections	16
Table 6.3. SPI Bus Connections	16
Table 7.1. DIP Switch Signals	17
Table 7.2. Push Button Switch Signals	17
Table 7.3. General Purpose LED Signals.....	17
Table 7.4. 7-Segment LED Signals	18
Table 11.1. Ordering Information	27

Acronyms in This Document

A list of acronyms used in this document.

Acronym	Definition
AC/DC	Alternating Current and Direct Current
caBGA	Chip Array Ball Grid Array
CMOS	Complementary Metal-Oxide Semiconductor
DDR	Double Data Rate
DIP	Dual Inline Package
ESD	Electro Static Discharge
FPGA	Field Programmable Logic Array
FTDI	Future Technology Devices International
GPIO	General Purpose Input/Output
I ² C	Inter-Integrated Circuit
JTAG	Joint Test Action Group
LED	Light Emitting Diode
LVDS	Low-Voltage Differential Signaling
PC	Personal Computer
PCIe	Peripheral Component Interconnect Express
PHY	Physical Layer Device
PMOD	Peripheral Module
RGMII	Reduced Gigabit Media Independent Interface
SGMII	Serial Gigabit Media Independent Interface
SPI	Serial Peripheral Interface
UART	UniPCIe Bridgel Asynchronous Receiver Transmitter
USB	UniPCIe Bridgel Serial Bus

1. Introduction

The Lattice Semiconductor CertusPro™-NX PCIe Bridge Board allows designers to investigate and experiment with the features of the CertusPro-NX Field Programmable Gate Array (FPGA). The features of the CertusPro-NX PCIe Bridge Board can assist engineers with the rapid prototyping and testing of their specific designs. This guide is intended to be referenced to demonstrate the CertusPro-NX FPGA and introduce board resource.

1.1. CertusPro-NX PCIe Bridge Board

The CertusPro-NX PCIe Bridge Board features the CertusPro-NX FPGA in the LFG672 package which is built on Lattice Nexus™ FPGA platform using low power 28 nm FD-SOI technology. The board has the ability to expand the usability of the CertusPro-NX FPGA with PCIe, CSI, USB3 Controller, FMC connector, PMOD, along with access to 2× SerDes channels. Easy-to-use board resources of the jumper, LED indicator, push button and switch are available for user-defined applications.

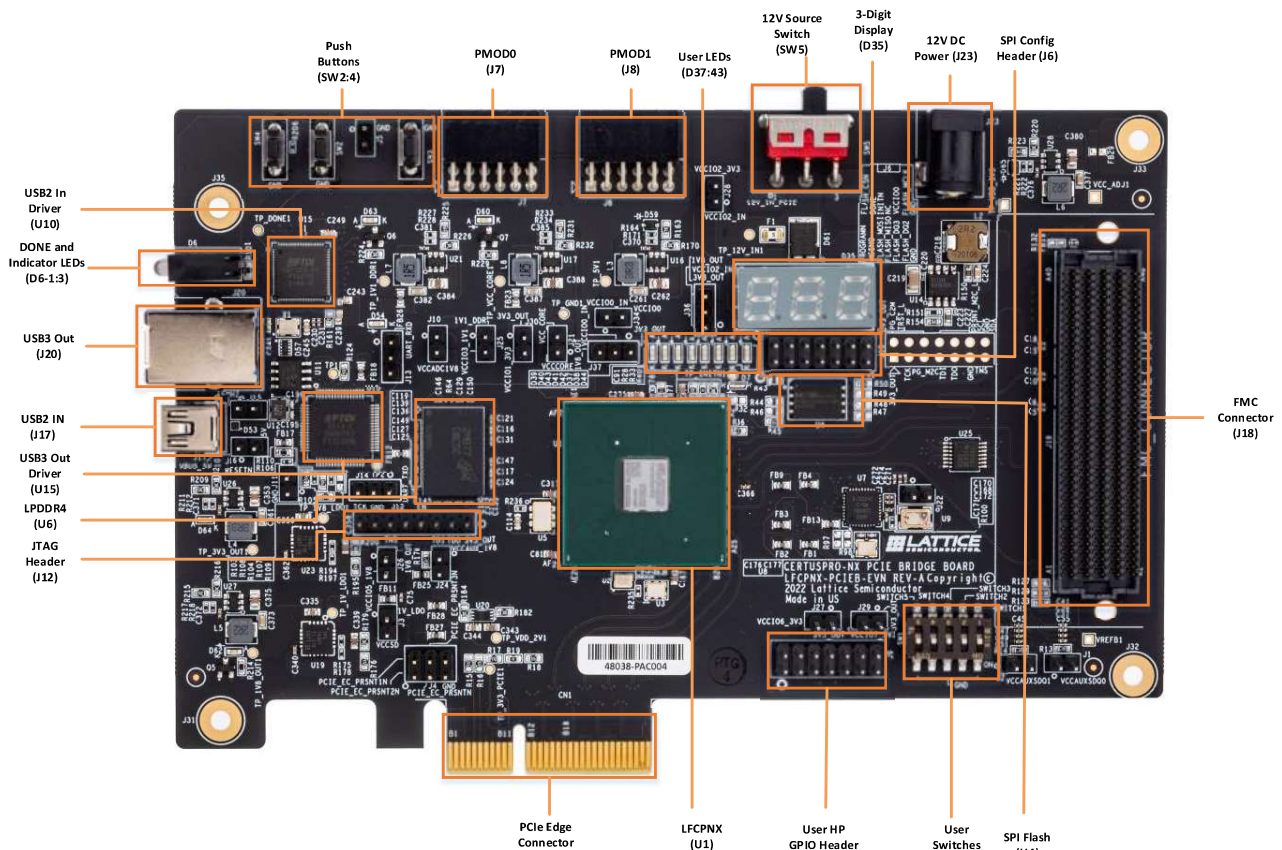

Figure 1.1. Top View of CertusPro-NX PCIe Bridge Board

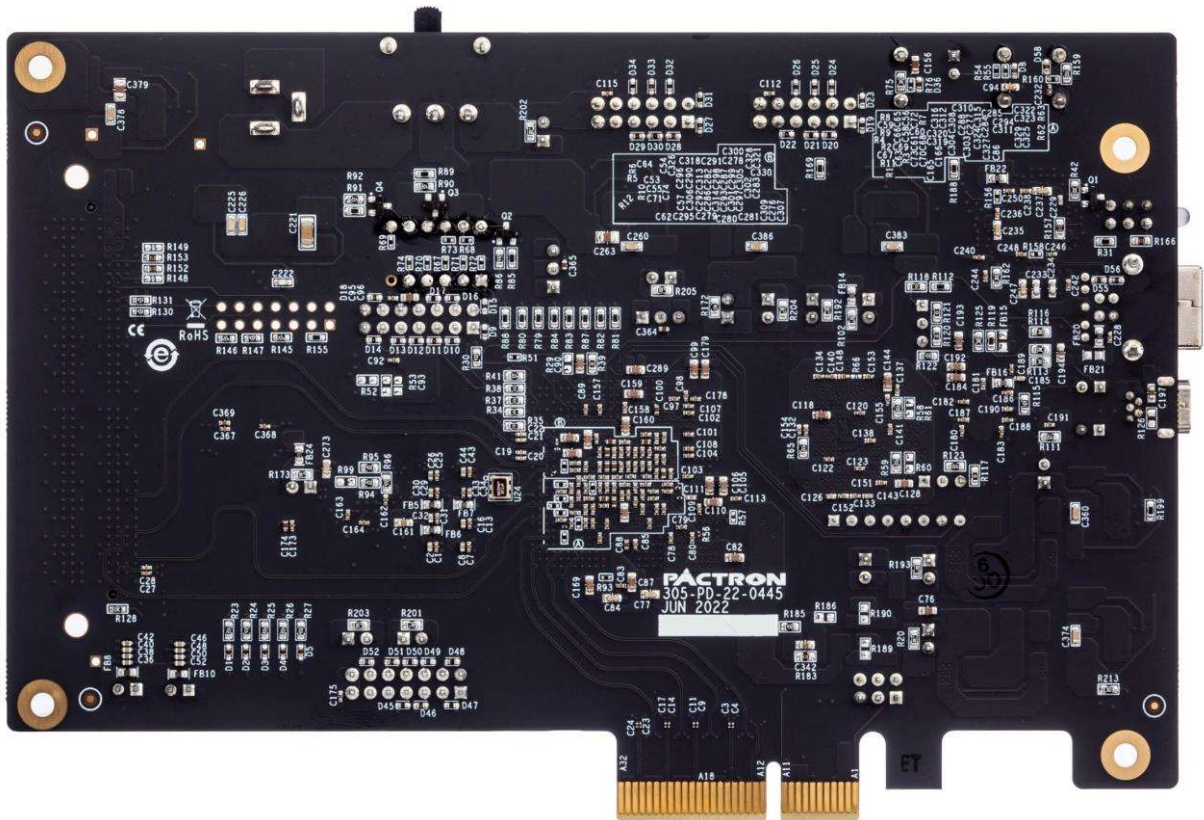

Figure 1.2. Bottom View of CertusPro-NX PCIe Bridge Board

Figure 1.1 shows the top view of CertusPro-NX PCIe Bridge Board. Figure 1.2 shows the bottom view of CertusPro-NX PCIe Bridge Board.

1.2. Features

The CertusPro-NX PCIe Bridge Board includes the following features:

- CertusPro-NX FPGA (LFCPNX-100-9LFG6721)
- PCIe x4 Gen3 supports
- LPDDR4 DRAM Memory
- On-board Boot Flash – 128 Mb Serial Peripheral Interface (SPI) Flash, with Quad read feature
- USB 3.0 Controller
- FMC connector
- USB-B connection for device programming and Inter-Integrated Circuit Bus (I2C) utility
- 7 Segment Display, five input DIP switches, three push buttons and 8 user configurable LEDs for customer purposes
- Lattice Radiant® software programming support
- Multiple reference clock sources

Caution: The CertusPro-NX PCIe Bridge Board contains ESD-sensitive components. ESD safe practices should be followed while handling and using the development board.

1.3. CertusPro-NX Device

The CertusPro-NX PCIe Bridge Board features the CertusPro-NX device in an LFG672 package, also referred to as LFCPNX-100-9LFG672I. The low-power general purpose FPGA can be used in a wide range of applications across multiple markets and is optimized for bridging and processing needs in edge applications. For more information on the capabilities of CertusPro-NX device, see [CertusPro-NX Family Data Sheet \(FPGA-DS-02086\)](#).

1.4. Applying Power to the Board

The CertusPro-NX PCIe Bridge Board comes ready to power up. The board can power up using a 12 V DC power source input. The power supply can be connected with the right-angle DC power input jack J23, which is fused with a surface mounted fuse F1, as shown in [Figure 1.3](#) and [Table 1.1](#). The fuse can prevent the crashed current from flowing into the internal circuits and cause serious damage. Power LEDs light after applying 12 V DC power to the CertusPro-NX Evaluation Board to indicate that the board is functioning. The board also comes with a flip switch (SW5) to enable the power-up either through the 12V power source or the PCIe slot.

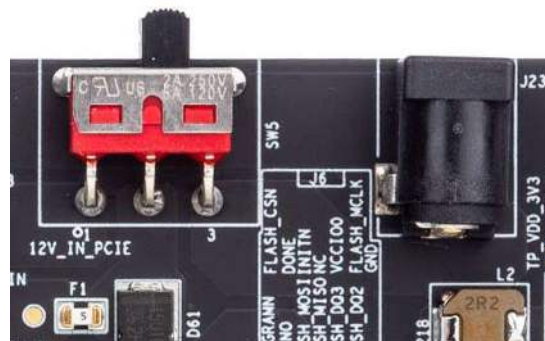
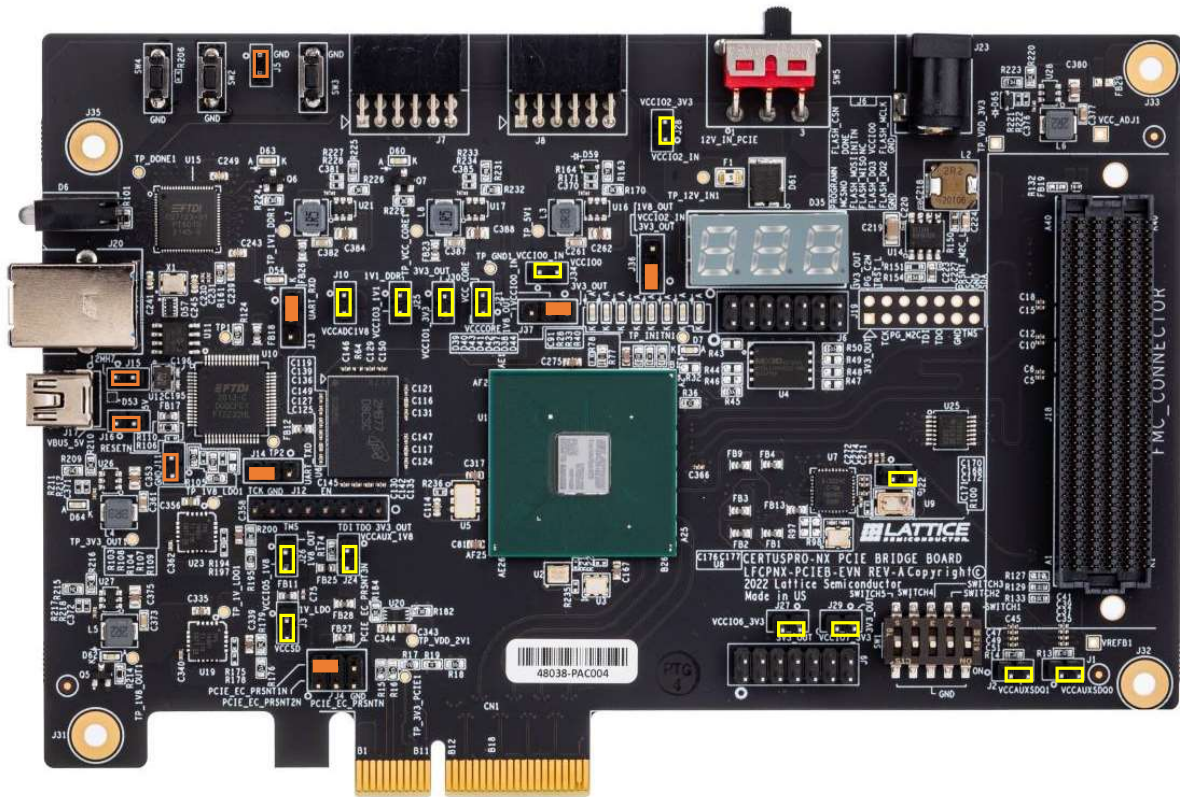

Figure 1.3. 12 V DC Power Supply

Table 1.1. Board Power Supply

Part Designator	Description
J23	12 V DC Input Supply Jack
F1	12 V DC Input Supply Fuse
SW5	—

2. Jumper Definitions



- = Placed Jumper by default
- = Empty Jumper by default
- = Current measuring jumper

Figure 2.1. Top View of CertusPro-NX PCIe Bridge Board – Jumper Selection

Table 2.1. Jumper Details

Part	Description	Settings
J16	Powering the board from USB 2.0	Default Open
J15	FTDI_12MHz reference clock for FPGA	Default Open
J11	FTDI RESET	Default OPEN (Active FTDI)/Short (Reset FTDI)
J5	PROGRAMN pulldown	Default Open
J13, J14	FTDI UART/ I2C Select	Default 1-2 Short (1-2 Short FTDI UART/2-3 Short for FTDI I2C)
J1, J2, J3, J10, J21, J22, J24, J25, J26, J27, J28, J29, J30, J34	Current Measurement 2 Pin Header	—
J4	PCIe Link selection	Default Short 2-4 for PCIe X4, Short 1-2 for PCIe X1
J36	VCCIO Selection for Bank 2	Default 1-2 for Short VCCIO2=3.3V, 2-3 for Short VCCIO2=1.8V
J37	VCCIO Selection for Bank 0	Default 1-2 for Short VCCIO0=3.3V, 2-3 for Short VCCIO0=1.8V

3. Programming and I²C

The JTAG/SPI programming architecture and I²C interface of the CertusPro-NX PCIe Bridge Board are shown in [Figure 3.1](#).

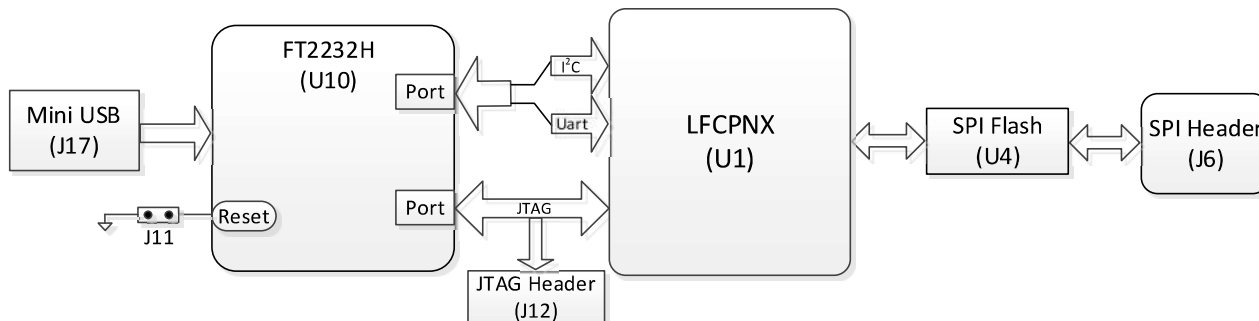

Figure 3.1. Configuration Architecture

3.1. JTAG Download Interface

The CertusPro-NX PCIe Bridge Board has a built-in download controller for programming the CertusPro-NX device. It uses an FT2232H Future Technology Devices International (FTDI) part to convert USB to JTAG. To use the built-in download cable, connect the USB cable from a PC with Radiant Programmer tool installed to the mini-USB connector on the board. The USB hub on the PC detects the cable of the USB function on Port 0, making the built-in cable available for use with the Radiant programming software.

3.2. Alternate JTAG Download Interface

J12 is an 8-pin standalone JTAG header used with an external Lattice download cable that is available separately, when the FTDI part is disabled from the JTAG chain after resetting FTDI. A USB download cable can be attached to the board using this JTAG Header to interface with the CertusPro-NX device. For details on the connection between the USB download cable and J12, refer to [Programming Cables User Guide \(FPGA-UG-02042\)](#).

JTAG Header can also be used as test point when USB to JTAG is working. The JTAG connection is shown in [Table 3.1](#).

Table 3.1. JTAG Connection

J12 Pin Number	Signal Name	CertusPro-NX Pin
1	3V3_OUT	—
2	TDO	M8
3	TDI	L9
4	JTAG_EN	K1
5	—	—
6	TMS	L7
7	GND	—
8	TCK	M5

3.3. Other FPGA Configuration Pins

The CertusPro-NX PCIe Bridge Board provides test points for other FPGA configuration pins as shown in [Table 3.2](#).

Table 3.2. Other JTAG Signals

Signal Name	CertusPro-NX Ball Location	Test Point	Push Button
PROGRAMN	G4	—	SW2
INITN	G2	TP_INITN	—
DONE	G5	TP_DONE1	—

- INITN: Open drain pin. This signal is driven to LOW when configuration sequence is started, indicating the device is in initialization state. At this moment, the LED (D7) is lit. This signal is released after initialization is completed, and the configuration download starts.
- DONE: Open drain pin. This signal is driven to LOW during configuration time. This signal releasing indicates the device has completed configuration. At this moment, the LED (D6-1) is lit.

For more information on Certus-NX JTAG and SPI programming, refer to [sysCONFIG Usage Guide for Nexus Platform \(FPGA-TN-02099\)](#).

3.4. JTAG to MSPI Pass-through Interface

The download controller can also access the JTAG to MSPI pass-through circuit that allows the slave SPI Flash to be erased, programmed, and read with Radiant Programmer.

3.5. SPI Flash Device Selection in Programmer

The Flash device on this board is a Macronix MX25L51245G which is powered by default to 3.3 V. Flash device programming is discussed in more detail in to [sysCONFIG Usage Guide for Nexus Platform \(FPGA-TN-02099\)](#).

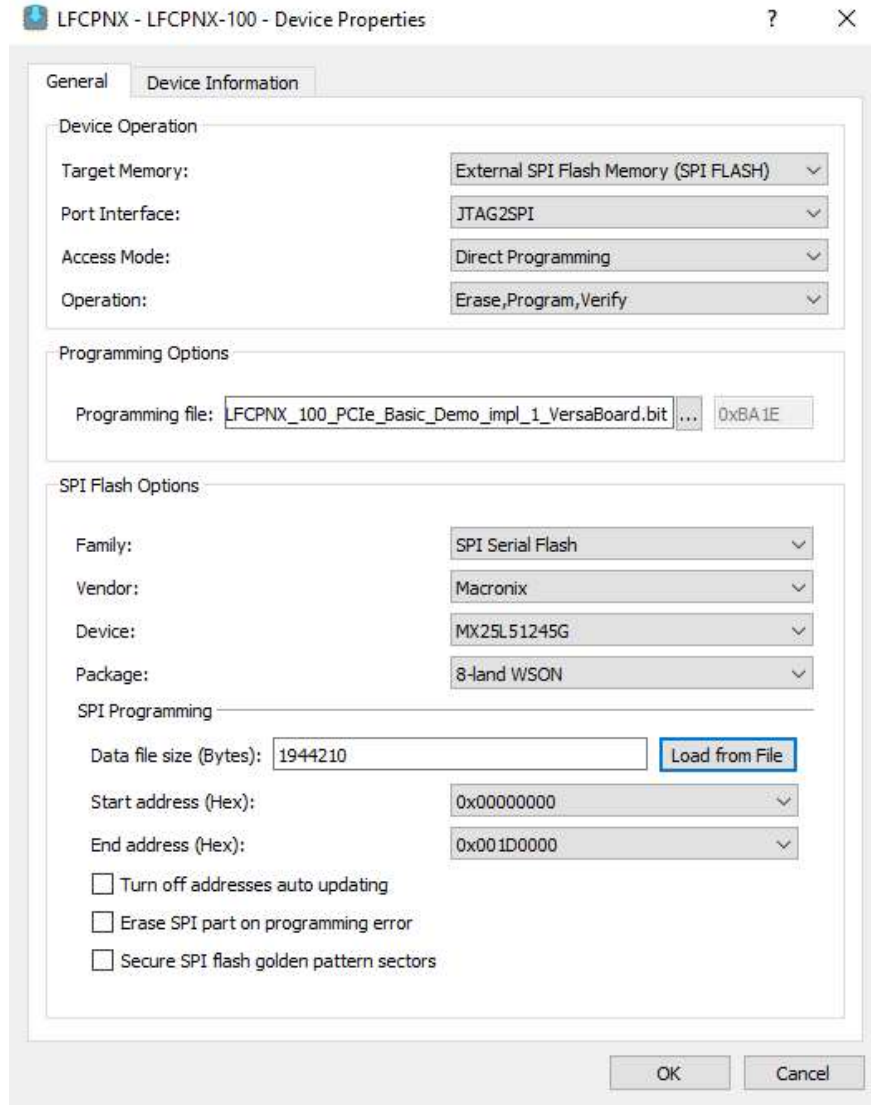

Figure 3.2. SPI Flash Operation Dialog

4. CertusPro-NX Clock Sources

The CertusPro-NX PCIe Bridge Board has three clock sources for the CertusPro-NX FPGA. Refer to [Table 4.1](#) and [Figure 4.1](#) for more details regarding the clock sources.

Table 4.1. Clock Sources

Clock Frequency	Signal Name	Clock Sources	CertusPro-NX Ball	Type
125 MHz	F_CLKIN_125MHZ	U2	P24	Single Ended
125 MHz	F_125MHZ_P F_125MHZ_N	U3	16/17 (PLL)	Differential
100 MHz	F_DDR_100MHZ_P F_DDR_100MHZ_N	U5	AB19 AB18	Differential
118.8 MHz	F_SLVS_118_P F_SLVS_118_N	U24	C14 D13	Differential
19.44 MHz	PLL_CLKIN2_P	U9	12 (PLL)	Single Ended
100 MHz	F_PCIE_100MHZ_P F_PCIE_100MHZ_N	CN1	F20 E20	Differential
User defined	FMC_LA00_CLK_P FMC_LA00_CLK_N	J18 (FMC)	V23 V22	Differential
User defined	FMC_LA01_CLK_P FMC_LA01_CLK_N	J18 (FMC)	W24 W23	Differential

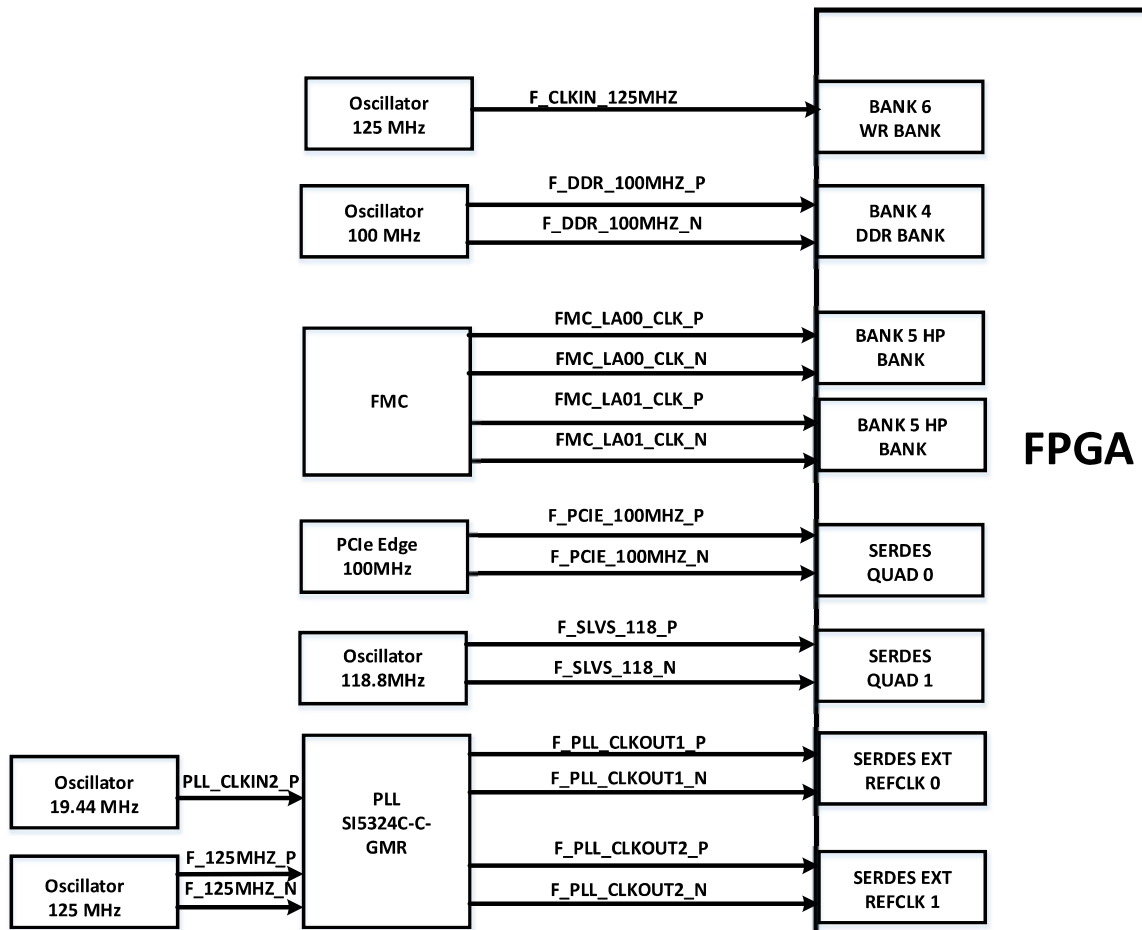

Figure 4.1. Clock Scheme

5. Power Scheme

The CertusPro-NX PCIe Bridge Board has most of the on-board regulators powered by an external 12 V power. Refer to [Appendix A. CertusPro-NX PCIe Bridge Board Schematics](#) to see the details of these power supply options.

[Figure 5.1](#) shows the high-level power supply architecture of the board. [Table 5.1](#) shows the voltage options available for various VCCIO supplies.

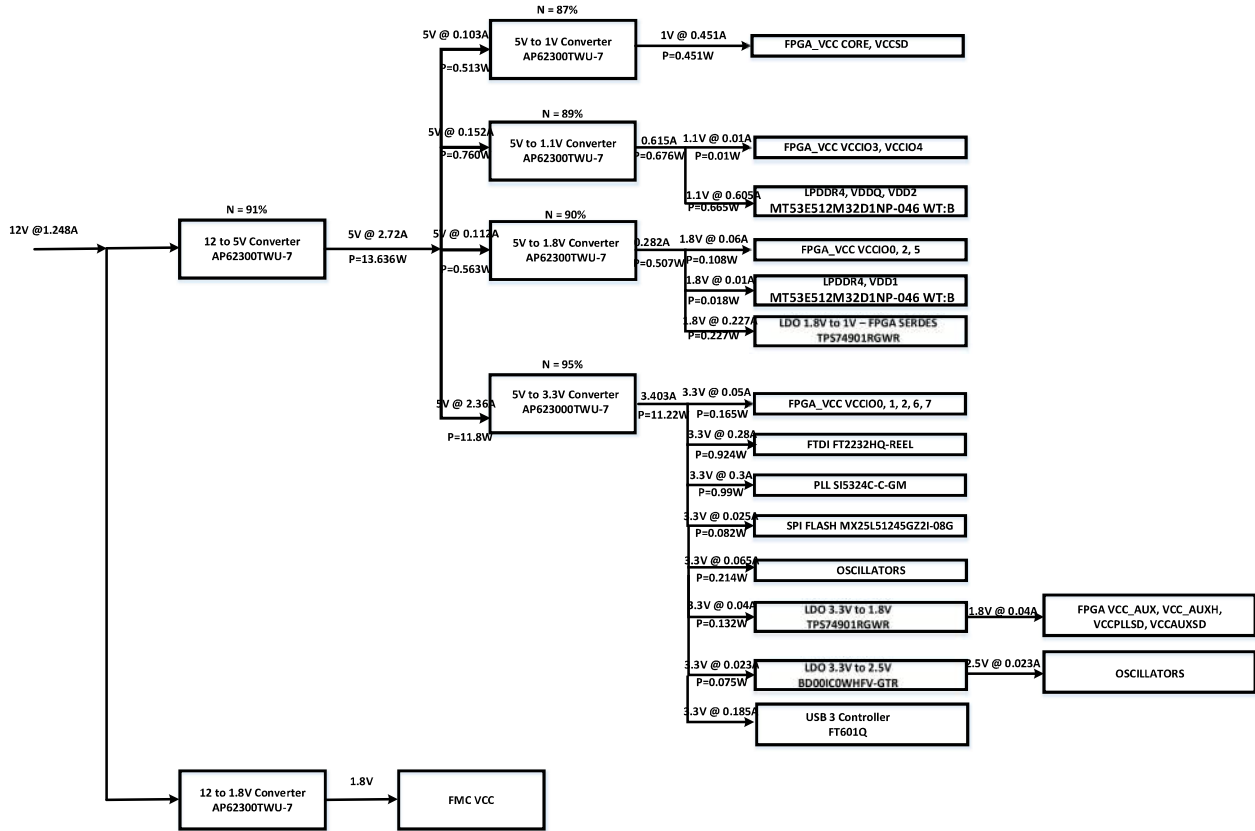

Figure 5.1. Power Scheme

Table 5.1. VCCIO Supply Options

VCCIO Bank	3.3 V	2.5 V	1.8 V	1.5 V	1.2 V	1.1 V
VCCIO0	Default	—	Selectable	—	—	—
VCCIO1	Fixed	—	—	—	—	—
VCCIO2	Default	—	Selectable	—	—	—
VCCIO3	—	—	—	—	—	Fixed
VCCIO4	—	—	—	—	—	Fixed
VCCIO5	—	—	Fixed	—	—	—
VCCIO6	Fixed	—	—	—	—	—
VCCIO7	Fixed	—	—	—	—	—

The CertusPro-NX PCIe Bridge Boards provide status LEDs to provide a visual indication of power status as shown in [Table 5.2](#).

Table 5.2. Status LED Definition

LED Designator	Color	Description
D6-3	Green	5V
D54	Green	3V3_OUT
D60	Green	VCC_CORE
D62	Green	1V8_OUT
D63	Green	1V1_DDR
D64	Green	3V3_OUT

6. Control Buses – I²C, UART, and SPI

This section describes the topology of the various configuration and communication buses.

6.1. I²C Topology

The CertusPro-NX PCIe Bridge Board uses the I²C bus to support CertusPro-NX configuration. The I²C bus has the signal names FTDI_I2C_SCL and FTDI_I2C_SDA. When the jumpers (J13, J14) are closed, the I²C bus is connected to a dedicated CertusPro-NX GPIO bank 1. I²C and UART share the same output port B on FTDI chip. The I²C connections are summarized in [Table 6.1](#).

Table 6.1. I²C Bus Connections

Signal Name	CertusPro-NX Ball Location	FTDI Chip Ball Location	Jumper
FTDI_I2C_SCL	M7	38	J14
FTDI_I2C_SDA	M6	39&40	J13

6.2. UART Topology

The board provides one UART communication interface by providing a flexible connection between the CertusPro-NX device and FTDI chip. Close the two jumpers, J13 and J14, to connect to two general-purpose I/O in Bank 1, as shown in [Table 6.2](#). This UART is alternative with I²C bus by setting FTDI configuration.

Table 6.2. UART Bus Connections

Signal Name	CertusPro-NX Ball Location	FTDI Chip Ball Location	Jumper
FTDI_UART_TXD	L8	38	J14
FTDI_UART_RXD	M9	39	J13

6.3. SPI Topology

6.3.1. SPI Configuration

One of the major functions of SPI connections on the board is to support CertusPro-NX configuration from the SPI Flash or the Parallel Configuration Header (J6), as shown in [Table 6.3](#). The CertusPro-NX PCIe Bridge Board can support both Master SPI (MSPI) and Slave SPI (SSPI) modes for CertusPro-NX configuration.

Table 6.3. SPI Bus Connections

Signal Name	CertusPro-NX Ball	Parallel Configuration Header Pin
CONN_FLASH_MCLK	G6	12
CONN_FLASH_MOSI	H7	5
CONN_FLASH_MISO	H6	7
CONN_FLASH_CS	G7	2
CONN_FLASH_DQ2	K5	11
CONN_FLASH_DQ3	H4	9
MCSNO	H3	3

7. LEDs and Switches

This section describes the CertusPro-NX PCIe Bridge Board LEDs and switches that can be used in demo and customer designs.

7.1. DIP Switch

Five CertusPro-NX pins are connected to the DIP switch (SW1) to allow manual actuating input to the FPGA. One side of each switch is connected to GPIOs within bank 5, and is pulled up through 4.7 kΩ resistors. The other side is grounded. The designated pins are connected as shown in [Table 7.1](#).

Table 7.1. DIP Switch Signals

Signal Name	CertusPro-NX Ball Location	CertusPro-NX Bank
SWITCH1	J21	5
SWITCH2	K20	5
SWITCH3	K24	5
SWITCH4	J25	5
SWITCH5	H26	5

7.2. Push Buttons

The CertusPro-NX PCIe Bridge Board provides four push button switches, SW2, SW3, SW7, for demo and user applications. One of the buttons is pre-defined functional pin, and the other three are generic pins. Pressing these buttons drives a logic level “0” to the corresponding I/O pins. The designated pins are connected as shown in [Table 7.2](#).

Table 7.2. Push Button Switch Signals

Signal Name	CertusPro-NX Ball Location	Push Button Reference	Logic Level at Button Pressed
PROGRAMN	G4	SW2	0
F_RESET_N	M3	SW3	0
F_USB3_0_RESET	H20	SW4	0

For more information on PROGRAMN, refer to [sysCONFIG Usage Guide for Nexus Platform \(FPGA-TN-02099\)](#).

7.3. General Purpose LEDs

The CertusPro-NX PCIe Bridge Board provides eight LEDs that are connected to I/O within Bank 1. The LEDs are lighted with green color when the output is driven LOW. The designated pins are connected as shown in [Table 7.3](#).

Table 7.3. General Purpose LED Signals

Signal Name	CertusPro-NX Ball Location	CertusPro-NX Bank/Color
LED_0	P8	1/Green
LED_1	U8	1/Green
LED_2	R4	1/Green
LED_3	R8	1/Green
LED_4	R7	1/Green
LED_5	R9	1/Green
LED_6	R5	1/Green
LED_7	R6	1/Green

7.4. 7-Segment LED

The CertusPro-NX PCIe Bridge Board provides one 3-digit 7-segment LEDs that are connected to I/O within Bank 1. The LEDs are lit based on a segment coding. The designated pins are connected as shown in [Table 7.4](#).

Table 7.4. 7-Segment LED Signals

Signal Name	CertusPro-NX Ball Location
SEG_A	L3
SEG_B	N9
SEG_C	N7
SEG_D	T4
SEG_E	N5
SEG_F	M4
SEG_G	N8
SEG_DP	N6
K_DIG1	L20
K_DIG2	L22
K_DIG3	L23

8. Headers/Connectors and CertusPro-NX Device Ball Mapping

This section describes the CertusPro-NX PCIe Bridge Board headers/connectors and ball mapping.

8.1. External Flash Configuration Header

Table 8.1. SPI Flash Configuration Header Pin Connections

J18 Pin Number	Signal Name	CertusPro-NX Ball Location
1	CONN_PROGRAMN	G4*
2	CONN_FLASH_CSN	G7*
3	MCSNO	H3
4	DONE	G5
5	CONN_FLASH_MOSI	H7*
6	CONN_INITN	G2*
7	CONN_FLASH_MISO	H6*
8	—	—
9	CONN_FLASH_DQ3	H4*
10	VCCIO0	—
11	CONN_FLASH_DQ2	K5*
12	CONN_FLASH_MCLK	G6*
13	GND	—
14	GND	—

*Note: These connections are possible if 0 Ω resistors installed.

8.2. PMOD Header

J7 and J8 headers can be used as GPIO or as a connector to PMOD interface.

Table 8.2. PMOD Header Pin Details

Pin Name	Signal Name	CertusPro-NX Ball Location	
J8	1	PMOD1_1	T1
	2	PMOD1_2	T2
	3	PMOD1_3	U3
	4	PMOD1_4	U6
	7	PMOD1_7	U2
	8	PMOD1_8	V5
	9	PMOD1_9	T3
	10	PMOD1_10	U7
J7	1	PMOD0_1	W4
	2	PMOD0_2	W2
	3	PMOD0_3	V2
	4	PMOD0_4	V3
	7	PMOD0_7	V4
	8	PMOD0_8	W1
	9	PMOD0_9	V1
	10	PMOD0_10	U1

8.3. PCIe Edge Connector

Table 8.3. PCIe Edge Connector Pin Details

CN1 Pin Name	Signal Name	CertusPro-NX Ball	CN1 Pin Name	Signal Name	CertusPro-NX Ball
A1	PCIE_EC_PRSENT1N	—	B1	12V_IN_PCIE	—
A2	12V_IN_PCIE	—	B2	12V_IN_PCIE	—
A3	12V_IN_PCIE	—	B3	12V_IN_PCIE	—
A4	GND	—	B4	GND	—
A5	No Connection	—	B5	PCIE_SMCLK	T8
A6	No Connection	—	B6	PCIE_SMDATA	T7
A7	No Connection	—	B7	GND	—
A8	No Connection	—	B8	3V3_PCIE	—
A9	3V3_PCIE	—	B9	PCIE_TRST	P9
A10	3V3_PCIE	—	B10	No Connection	—
A11	F_PCIE_EC_PRSENTN	U23	B11	PCIE_WAKE	P19
A12	GND	—	B12	No Connection	—
A13	F_PCIE_100MHz_P	F20	B13	GND	—
A14	F_PCIE_100MHz_N	E20	B14	PCIE_RXD0_P	G24
A15	GND	—	B15	PCIE_RXD0_N	G25
A16	PCIE_TXD0_P	F26	B16	GND	—
A17	PCIE_TXD0_N	E26	B17	PCIE_EC_PRSENT2N	—
A18	GND	—	B18	GND	—
A19	No Connection	—	B19	PCIE_RXD1_P	E24
A20	GND	—	B20	PCIE_RXD1_N	D25
A21	PCIE_TXD1_P	C26	B21	GND	—
A22	PCIE_TXD1_N	B26	B22	GND	—
A23	GND	—	B23	PCIE_RXD2_P	C24
A24	GND	—	B24	PCIE_RXD2_N	B23
A25	PCIE_TXD2_P	A25	B25	GND	—
A26	PCIE_TXD2_N	A24	B26	GND	—
A27	GND	—	B27	PCIE_RXD3_P	C21
A28	GND	—	B28	PCIE_RXD3_N	C22
A29	PCIE_TXD3_P	A22	B29	GND	—
A30	PCIE_TXD3_N	A21	B30	No Connection	—
A31	GND	—	B31	PCIE_EC_PRSENT3N	—
A32	No Connection	—	B32	GND	—

8.4. HP_GPIO HEADER

Table 8.4. HP_GPIO HEADER Pin Details

J9 Pin Number	Signal Name	CertusPro-NX Ball Location
1	GND	—
2	GND	—
3	HP_GPIO6	L26
4	HP_GPIO1	L25
5	HP_GPIO7	L21
6	HP_GPIO2	K26
7	HP_GPIO8	K19
8	HP_GPIO3	K21

J9 Pin Number	Signal Name	CertusPro-NX Ball Location
9	No Connection	—
10	HP_GPIO4	J26
11	No Connection	—
12	HP_GPIO5	K25
13	VCCIO7_3V3	—
14	VCCIO7_3V3	—

8.5. Parallel FMC CFG Header

Table 8.5. Parallel FMC CFG Header Pin Details

J19 Pin Number	Signal Name	CertusPro-NX Ball Location	FMC Connector Location
1	3V3_OUT	—	—
2	3V3_OUT	—	—
3	FMC_TCK	T26	D29
4	FMC_PG_C2M	T25	D1
5	FMC_PG_M2C	R26	F1
6	FMC_TRST_L	—	D34
7	FMC_TDI	R25	D30
8	FMC_PRSNT_M2C_L	P20	H2
9	FMC_TDO	T24	D31
10	FMC_SCL	T22	C30
11	GND	—	—
12	GND	—	—
13	FMC_TMS	R22	D33
14	FMC_SDA	R21	C31

8.6. FMC Connector

Table 8.6. FMC Connector Pin Details

FMC Pin Number	Signal Name	CertusPro-NX Ball Location
A2	FMC_SD5_RXD_P	C16
A3	FMC_SD5_RXD_N	B16
A6	FMC_SD6_RXD_P	B13
A7	FMC_SD6_RXD_N	C12
A10	FMC_SD7_RXD_P	B10
A11	FMC_SD7_RXD_N	C10
A22	FMC_SD5_TXD_P	A15
A23	FMC_SD5_TXD_N	A14
A26	FMC_SD6_TXD_P	A12
A27	FMC_SD6_TXD_N	A11
A30	FMC_SD7_TXD_P	A9
A31	FMC_SD7_TXD_N	A8
B1	FMC_RES1	R18
B40	FMC_RES0	R19
C2	FMC_SD4_TXD_P	A18
C3	FMC_SD4_TXD_N	A17
C6	FMC_SD4_RXD_P	B20
C7	FMC_SD4_RXD_N	B19

FMC Pin Number	Signal Name	CertusPro-NX Ball Location
C10	FMC_LA06_P	AF15
C11	FMC_LA06_N	AF16
C14	FMC_LA10_P	AD20
C15	FMC_LA10_N	AC19
C18	FMC_LA14_P	Y14
C19	FMC_LA14_N	AA14
C22	FMC_LA18_P	AE13
C23	FMC_LA18_N	AE12
C26	FMC_LA27_P	V24
C27	FMC_LA27_P	V25
C30	FMC_SCL	T22
C31	FMC_SDA	R21
C34	FMC_GA0	-
D1	FMC_PG_C2M	T25
D4	FMC_GBTCLK0_M2C_P	AC21
D5	FMC_GBTCLK0_M2C_N	AD22
D8	FMC_LA01_CLK_P	W24
D9	FMC_LA01_CLK_N	W23
D11	FMC_LA05_P	AC18
D12	FMC_LA05_N	AD18
D14	FMC_LA09_P	AF19
D15	FMC_LA09_N	AE19
D17	FMC_LA13_P	AF22
D18	FMC_LA13_N	AF23
D20	FMC_LA17_CLK_P	AD14
D21	FMC_LA17_CLK_N	AE14
D23	FMC_LA23_P	R20
D24	FMC_LA23_N	T21
D26	FMC_LA26_P	AA17
D27	FMC_LA26_N	Y17
D29	FMC_TCK	T26
D30	FMC_TDI	R25
D31	FMC_TDO	T24
D33	FMC_TMS	R22
D34	FMC_TRST_L	-
D35	FMC_GA1	-
F1	FMC_PG_M2C	R26
G2	FMC_CLK1_M2C_P	AC13
G3	FMC_CLK1_M2C_N	AD13
G6	FMC_LA00_CLK_P	V23
G7	FMC_LA00_CLK_P	V22
G9	FMC_LA03_P	AE26
G10	FMC_LA03_N	AF25
G12	FMC_LA08_P	Y18
G13	FMC_LA08_N	AA18
G15	FMC_LA12_P	AC25
G16	FMC_LA12_N	AD26
G18	FMC_LA16_P	AC26

FMC Pin Number	Signal Name	CertusPro-NX Ball Location
G19	FMC_LA16_N	AB26
G21	FMC_LA20_P	U19
G22	FMC_LA20_N	U18
G24	FMC_LA22_P	AB25
G25	FMC_LA22_N	AC24
G27	FMC_LA25_P	AA23
G28	FMC_LA25_N	AA24
G30	FMC_LA29_P	AB22
G31	FMC_LA29_N	AA22
G33	FMC_LA31_P	W22
G34	FMC_LA31_N	W21
G36	FMC_LA33_P	U26
G37	FMC_LA33_N	V26
H2	FMC_PRSNT_M2C_L	P20
H4	FMC_CLK0_M2C_P	AD21
H5	FMC_CLK0_M2C_N	AE21
H7	FMC_LA02_P	AE24
H8	FMC_LA02_N	AF24
H10	FMC_LA04_P	AF21
H11	FMC_LA04_N	AF20
H13	FMC_LA07_P	AD25
H14	FMC_LA07_N	AE25
H16	FMC_LA11_P	AF14
H17	FMC_LA11_N	AF13
H19	FMC_LA15_P	AE22
H20	FMC_LA15_N	AE23
H22	FMC_LA19_P	AB23
H23	FMC_LA19_N	AB24
H25	FMC_LA21_P	W25
H26	FMC_LA21_N	W26
H28	FMC_LA24_P	AC22
H29	FMC_LA24_N	AD23
H31	FMC_LA28_P	AC20
H32	FMC_LA28_N	AB20
H34	FMC_LA30_P	W17
H35	FMC_LA30_N	W18
H37	FMC_LA32_P	W15
H38	FMC_LA32_N	W14

8.7. USB Chip Connector

Table 8.7. USB chip Connector Pin Details

U15 Pin Number	Signal Name	CertusPro-NX Ball Location
1	GND	—
2	AVDD	—
3	VD10	—
4	F_USB_BE0	M1
5	F_USB_BE1	N1

U15 Pin Number	Signal Name	CertusPro-NX Ball Location
6	F_USB_BE2	M2
7	F_USB_BE3	N2
8	F_USB_TXEn	L1
9	F_USB_RXFn	N3
10	USB_VIO_3V3	—
11	F_USB_SLWRN	K8
12	F_USB_SLRDN	N4
13	F_USB_SLOEN	L6
14	USB_VIO_3V3	—
15	F_USB3.0_RESETN	H20
16	F_USB_INTN	AB2
40	F_USB_DQ0	V18
41	F_USB_DQ1	V19
42	F_USB_DQ2	U24
43	F_USB_DQ3	V21
44	F_USB_DQ4	V20
45	F_USB_DQ5	U25
46	F_USB_DQ6	K7
47	F_USB_DQ7	J5
48	VD10	—
49	USB_VIO_3V3	—
50	F_USB_DQ8	K6
51	F_USB_DQ9	J7
52	F_USB_DQ10	K4
53	F_USB_DQ11	J6
54	F_USB_DQ12	K2
55	F_USB_DQ13	J2
56	F_USB_DQ14	J3
57	F_USB_DQ15	J1
58	F_USB_PCLK	P22
59	USB_VIO_3V3	—
60	F_USB_DQ16	V7
61	F_USB_DQ17	W5
62	F_USB_DQ18	W6
63	F_USB_DQ19	V6
64	F_USB_DQ20	W3
65	F_USB_DQ21	AA2
66	F_USB_DQ22	AB1
67	F_USB_DQ23	Y2
68	USB_VIO_3V3	—
69	F_USB_DQ24	AA1
70	F_USB_DQ25	Y1
71	F_USB_DQ26	W7
72	F_USB_DQ27	Y4
73	F_USB_DQ28	V8
74	F_USB_DQ29	AA4
75	F_USB_DQ30	H2
76	F_USB_DQ31	H1

U15 Pin Number	Signal Name	CertusPro-NX Ball Location
77	GND	—

8.8. LPDDR4 Connections

Table 8.8. LPDDR4 Connector Pin Details

LPDDR4 Pin Number	Signal Name	CertusPro-NX Ball Location
B2	F_LPDDR4_DQ0_A	AD3
C2	F_LPDDR4_DQ1_A	AC4
E2	F_LPDDR4_DQ2_A	AA6
F2	F_LPDDR4_DQ3_A	Y5
F4	F_LPDDR4_DQ4_A	Y6
E4	F_LPDDR4_DQ5_A	AA5
C4	F_LPDDR4_DQ6_A	AD4
B4	F_LPDDR4_DQ7_A	AE4
B11	F_LPDDR4_DQ8_A	AD6
C11	F_LPDDR4_DQ9_A	AE6
E11	F_LPDDR4_DQ10_A	AB7
F11	F_LPDDR4_DQ11_A	AC7
F9	F_LPDDR4_DQ12_A	AA7
E9	F_LPDDR4_DQ13_A	Y7
C9	F_LPDDR4_DQ14_A	AB6
B9	F_LPDDR4_DQ15_A	AC6
D3	F_LPDDR4_LDQS_A_P	AF4
E3	F_LPDDR4_LDQS_A_N	AF3
D10	F_LPDDR4_LDQS_A_P	AF6
E10	F_LPDDR4_LDQS_A_N	AF5
C3	F_LPDDR4_LDM_A	AE3
C10	F_LPDDR4_UDM_A	AD5
AA2	F_LPDDR4_DQ0_B	W10
Y2	F_LPDDR4_DQ1_B	W11
V2	F_LPDDR4_DQ2_B	AD10
U2	F_LPDDR4_DQ3_B	AD9
U4	F_LPDDR4_DQ4_B	AE10
V4	F_LPDDR4_DQ5_B	AE9
Y4	F_LPDDR4_DQ6_B	AA10
AA4	F_LPDDR4_DQ7_B	Y10
AA11	F_LPDDR4_DQ8_B	AA12
Y11	F_LPDDR4_DQ9_B	AB12
V11	F_LPDDR4_DQ10_B	AD12
U11	F_LPDDR4_DQ11_B	AC11
U9	F_LPDDR4_DQ12_B	AE11
V9	F_LPDDR4_DQ13_B	AD11
Y9	F_LPDDR4_DQ14_B	AB11
AA9	F_LPDDR4_DQ15_B	Y11
W3	F_LPDDR4_LDQS_B_P	AF10
V3	F_LPDDR4_LDQS_B_N	AF9
W10	F_LPDDR4_UDQS_B_P	AF12
V10	F_LPDDR4_UDQS_B_N	AF11

LPDDR4 Pin Number	Signal Name	CertusPro-NX Ball Location
Y3	F_LPDDR4_LDM_B	AB9
Y10	F_LPDDR4_UDM_B	AC12
H4, R4	F_LPDDR4_CS_A	Y13
H2, R2	F_LPDDR4_A0_A	AE15
J2, P2	F_LPDDR4_A1_A	AD15
H9, R9	F_LPDDR4_A2_A	AC15
H10, R10	F_LPDDR4_A3_A	AB15
H11, R11	F_LPDDR4_A4_A	Y16
J11, P11	F_LPDDR4_A5_A	W16
J4, P4	F_LPDDR4_CKE_A	Y12
J8, P8	F_LPDDR4_CLK_A_P	AA13
J9, P9	F_LPDDR4_CLK_A_N	AB13
G2	ODT_CA_A	-
T2	ODT_CA_B	-
T11	F_LPDDR4_RESET_B	W13

9. Software Requirements

The following software versions are required to develop designs for the CertusPro-NX PCIe Bridge Board:

- Lattice Radiant Software 3.0 or later
- Lattice Radiant Programmer 3.0 or later

10. Storage and Handling

Static electricity can shorten the life span of electronic components. Observe these tips to prevent damage that can occur from electrostatic discharge:

- Use antistatic precautions such as operating on an antistatic mat and wearing an antistatic wristband.
- Store the development board in the provided packaging.
- Touch a metal USB housing to equalize voltage potential between you and the board.

11. Ordering Information

Table 11.1. Ordering Information

Description	Ordering Part Number	China RoHS Environment-Friendly Use Period (EFUP)
CertusPro-NX PCIe Bridge Board	LFCPNX-PCIE BRIDGE-EVN	

Appendix A. CertusPro-NX PCIe Bridge Board Schematics

CertusPro-NX PCIe Bridge Board

Rev A

01. TITLE PAGE
02. BLOCK DIAGRAM
03. SERDES QUADS, PCIe edge
04. BANK5,6,1G SFP,DIP SW,HP GPIO HEADER
05. BANK0,SPI FLASH,CONFIG PIN
06. BANK2,BANK3, BANK4, PMOD0 & PMOD1
07. LPDDR4
08. BANK1,LEDS, 7 SEG DISPLAY
09. BANK7, PLL, RASPBERRY_CONN
10. ADC,VSS, VSSSDQ
11. FTDI High-Speed USB
12. FMC_HPC_SECTION
13. USB_FTD601_SECTION
14. POWER_SUPPLY_SECTION_1
15. POWER_SUPPLY_SECTION_2
16. POWER_SUPPLY_SECTION_3
17. POWER DIAGRAM
18. CLOCK DIAGRAM

	
Lattice Semiconductor Applications http://www.latticesemi.com/Support	
COVER_PAGE	
Rev: A3	Schematic Rev: 1.0
Part: 10200000000000000000	Board Rev: A
Doc: 10200000000000000000	Doc Rev: 1.0

Figure A. 1. Cover Page

BLOCK DIAGRAM

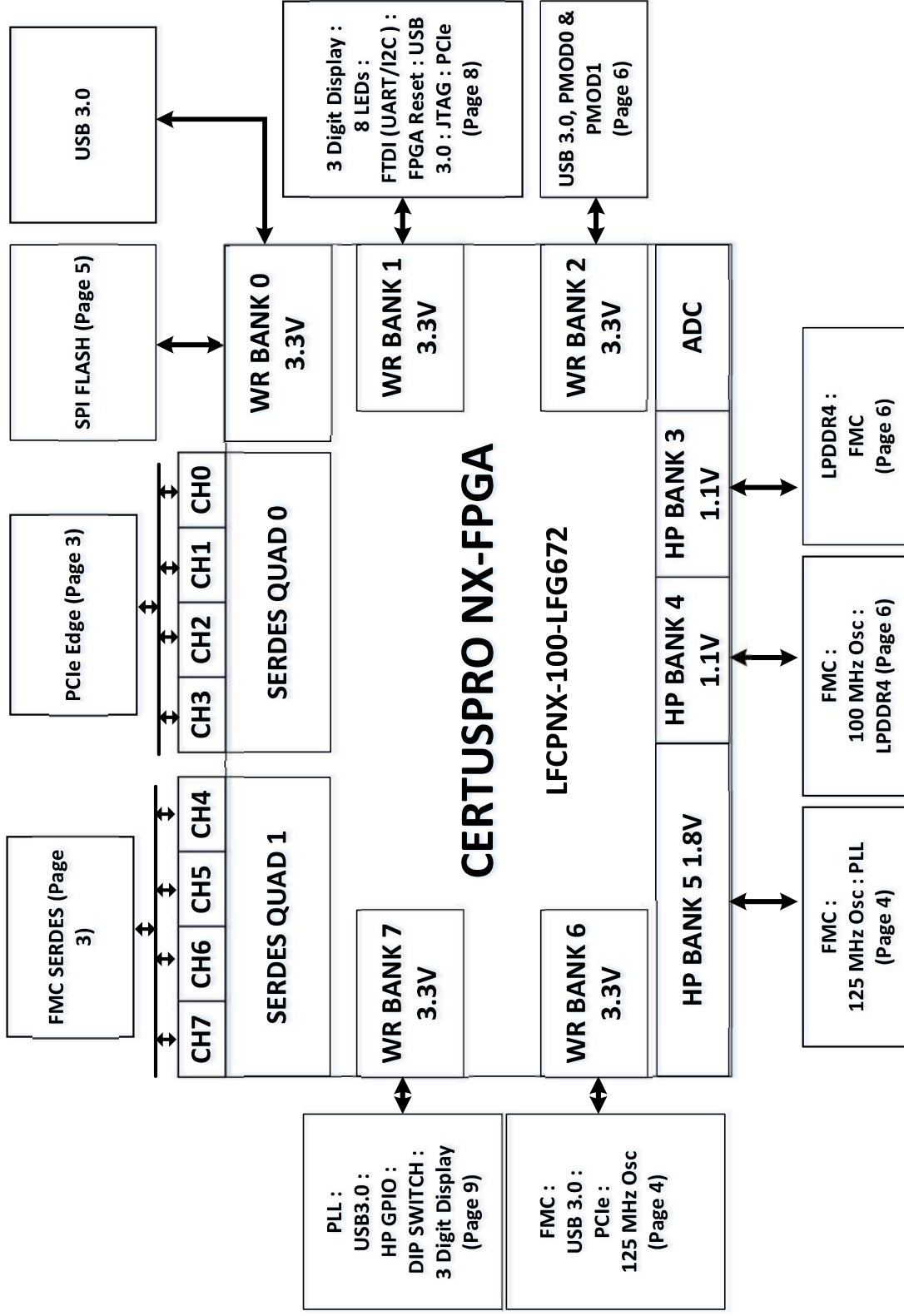

Figure A. 2. Block Diagram

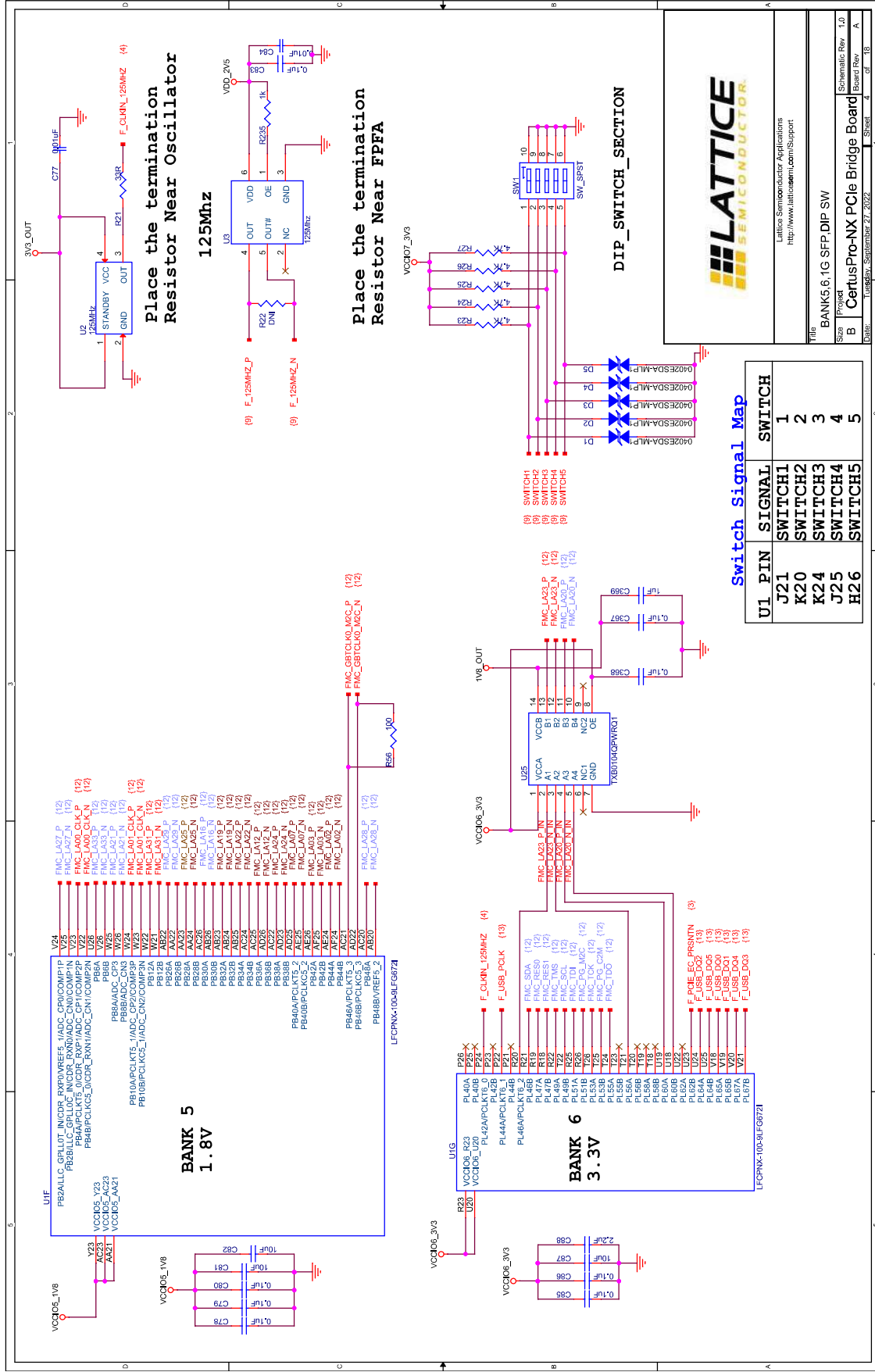

Figure A. 4. BANK5,6,1G SFP, DIP SW

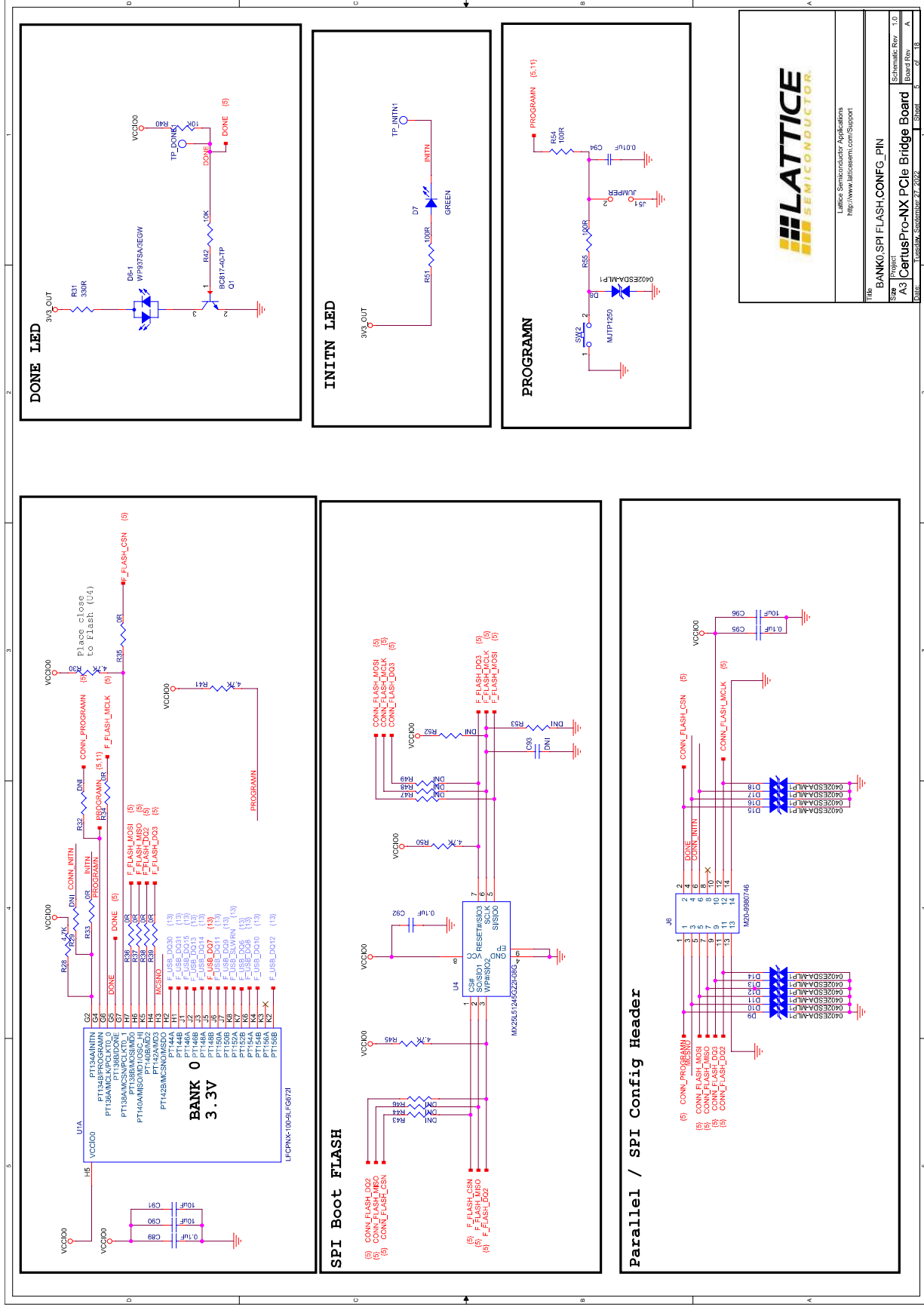

Figure A. 5. BANK0,SPI FLASH,CONFIG_PIN

© 2022 Lattice Semiconductor Corp. All Lattice trademarks, registered trademarks, patents, and disclaimers are as listed at www.latticesemi.com/legal. All other brand or product names are trademarks or registered trademarks of their respective holders. The specifications and information herein are subject to change without notice.

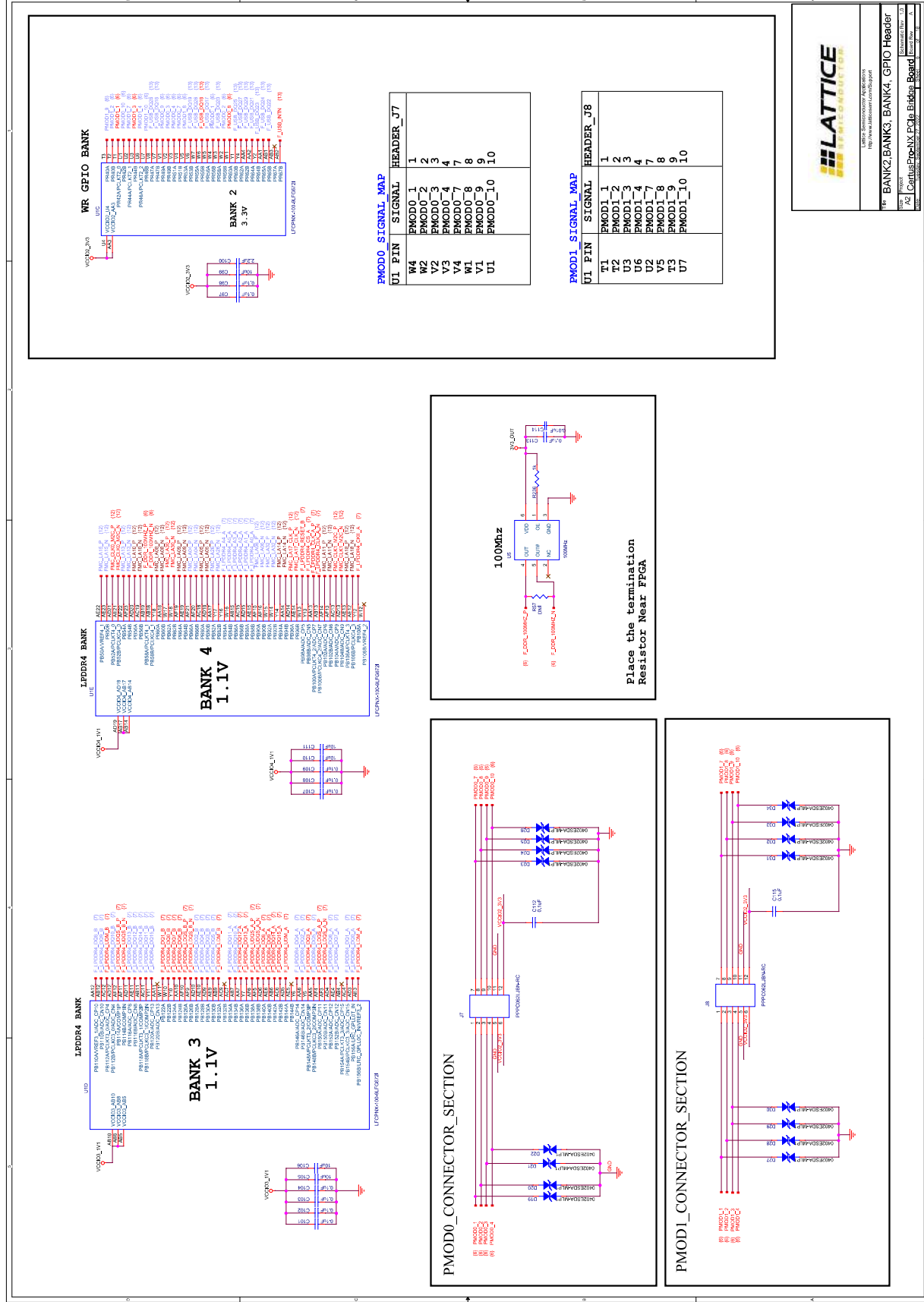
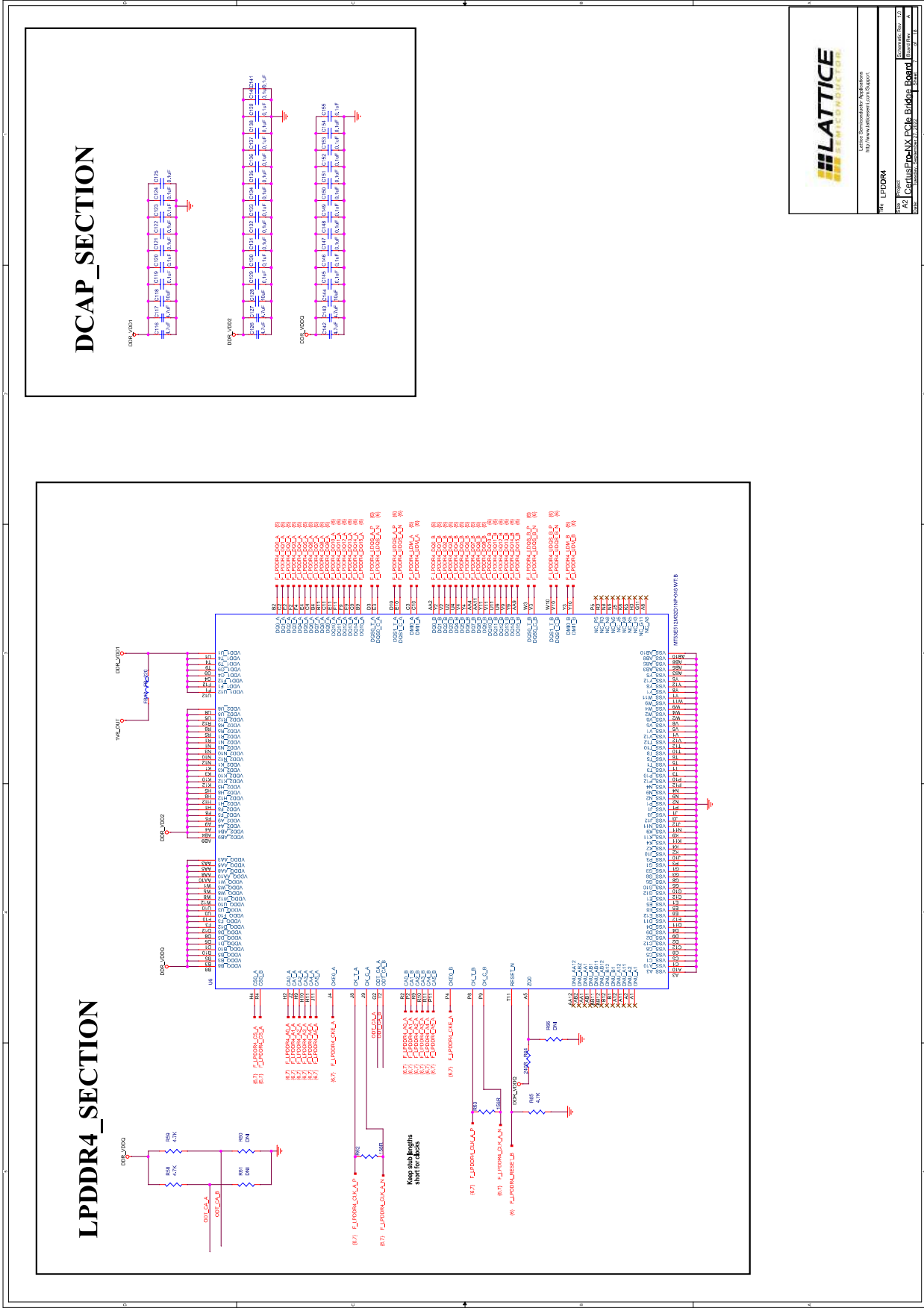

Figure A.6. BANK2, BANK3, BANK4, GPIO Header



LATTICE SEMICONDUCTOR
 10000 North Dallas Expressway
 Dallas, Texas 75243-1999
 www.lattice.com

Part: LPDDR4
 Rev: 1.0
 Copyright © 2022 Lattice Semiconductor Corporation

Figure A. 7. LPDDR4

© 2022 Lattice Semiconductor Corp. All Lattice trademarks, registered trademarks, patents, and disclaimers are as listed at www.latticesemi.com/legal. All other brand or product names are trademarks or registered trademarks of their respective holders. The specifications and information herein are subject to change without notice.

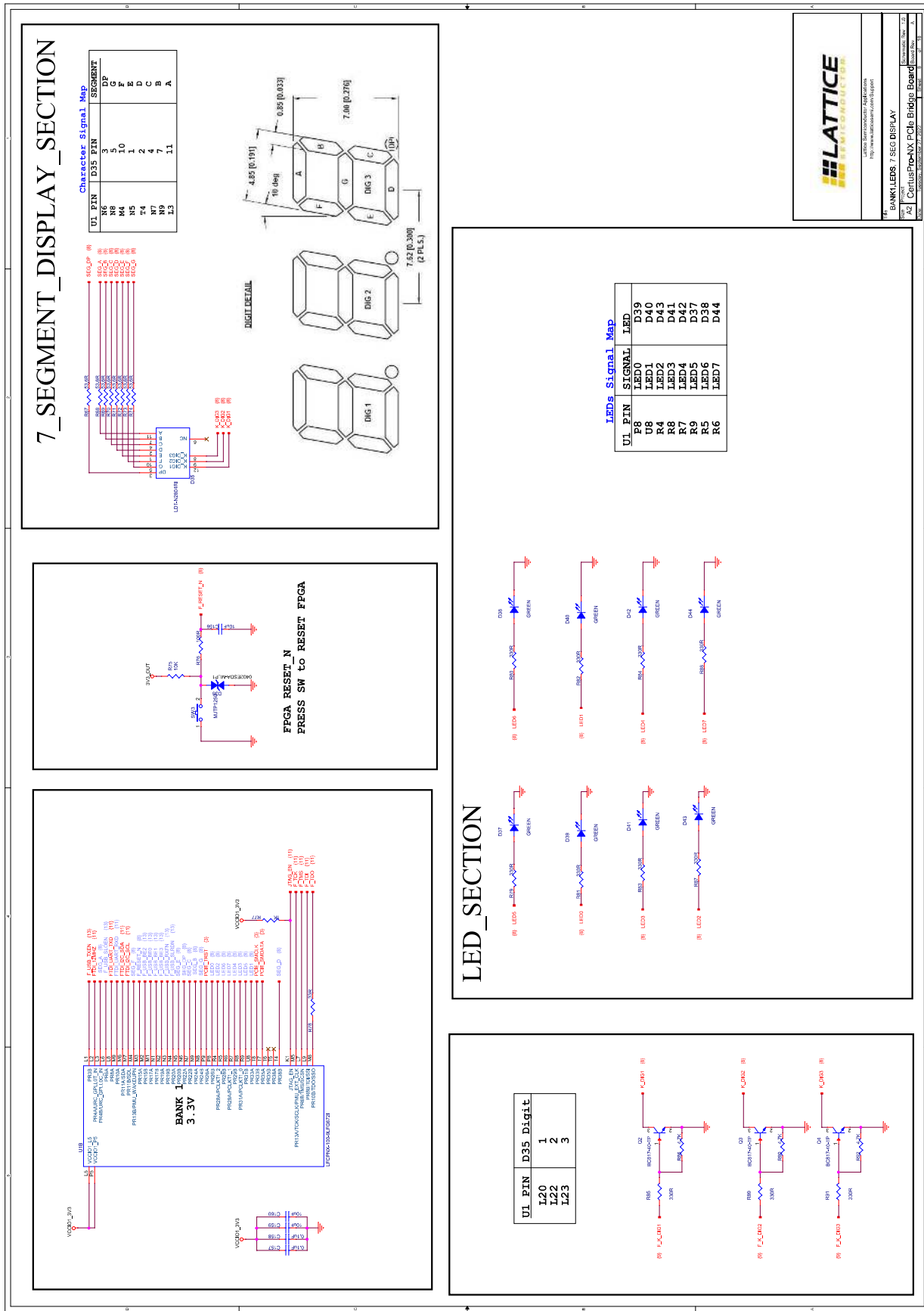

Figure A. 8. BANK1,LEDs, 7 SEG DISPLAY

© 2022 Lattice Semiconductor Corp. All Lattice trademarks, registered trademarks, patents, and disclaimers are as listed at www.latticesemi.com/legal. All other brand or product names are trademarks or registered trademarks of their respective holders. The specifications and information herein are subject to change without notice.

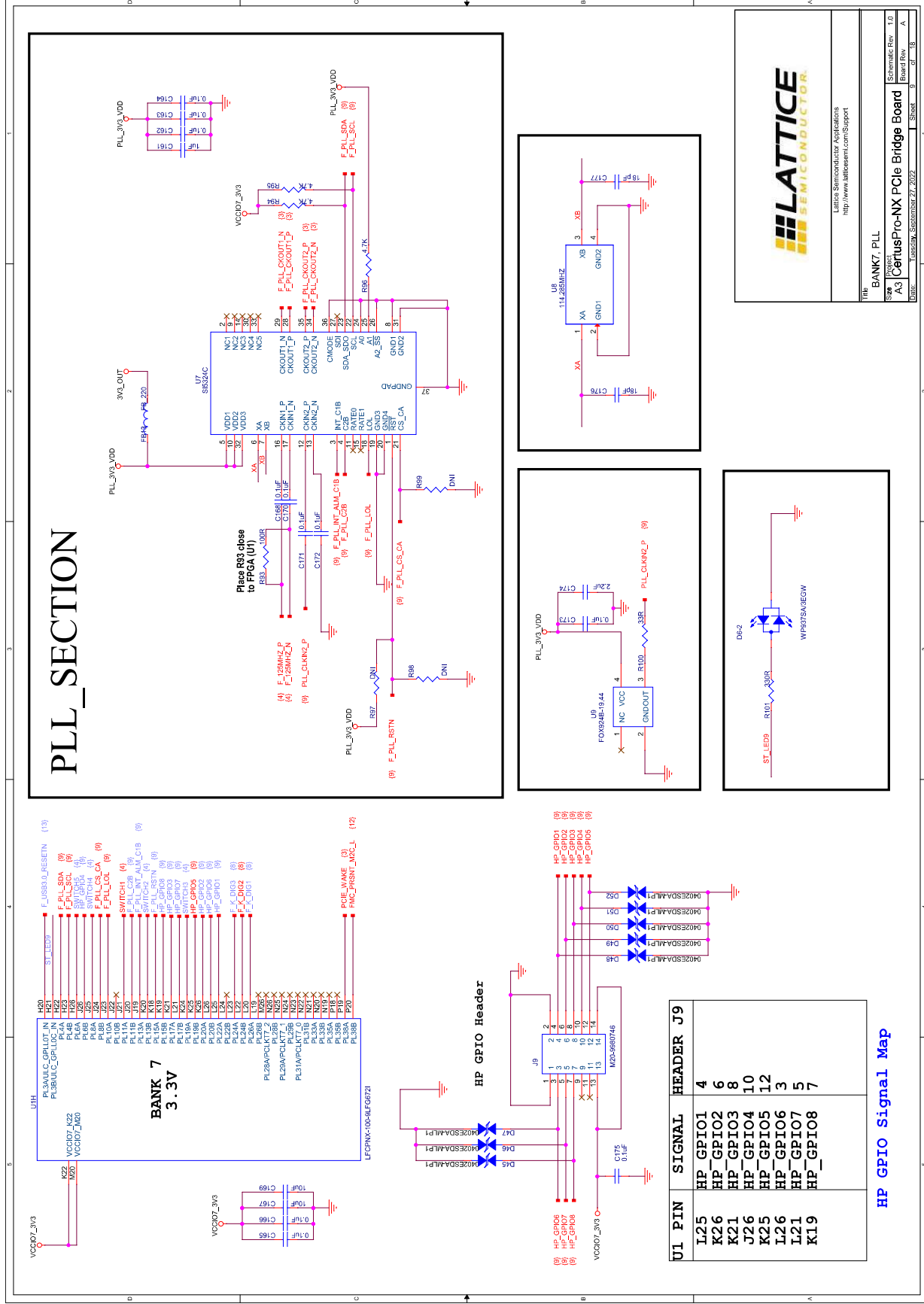

Figure A. 9. BANK7, PLL

© 2022 Lattice Semiconductor Corp. All Lattice trademarks, registered trademarks, patents, and disclaimers are as listed at www.latticeemi.com/legal. All other brand or product names are trademarks or registered trademarks of their respective holders. The specifications and information herein are subject to change without notice.

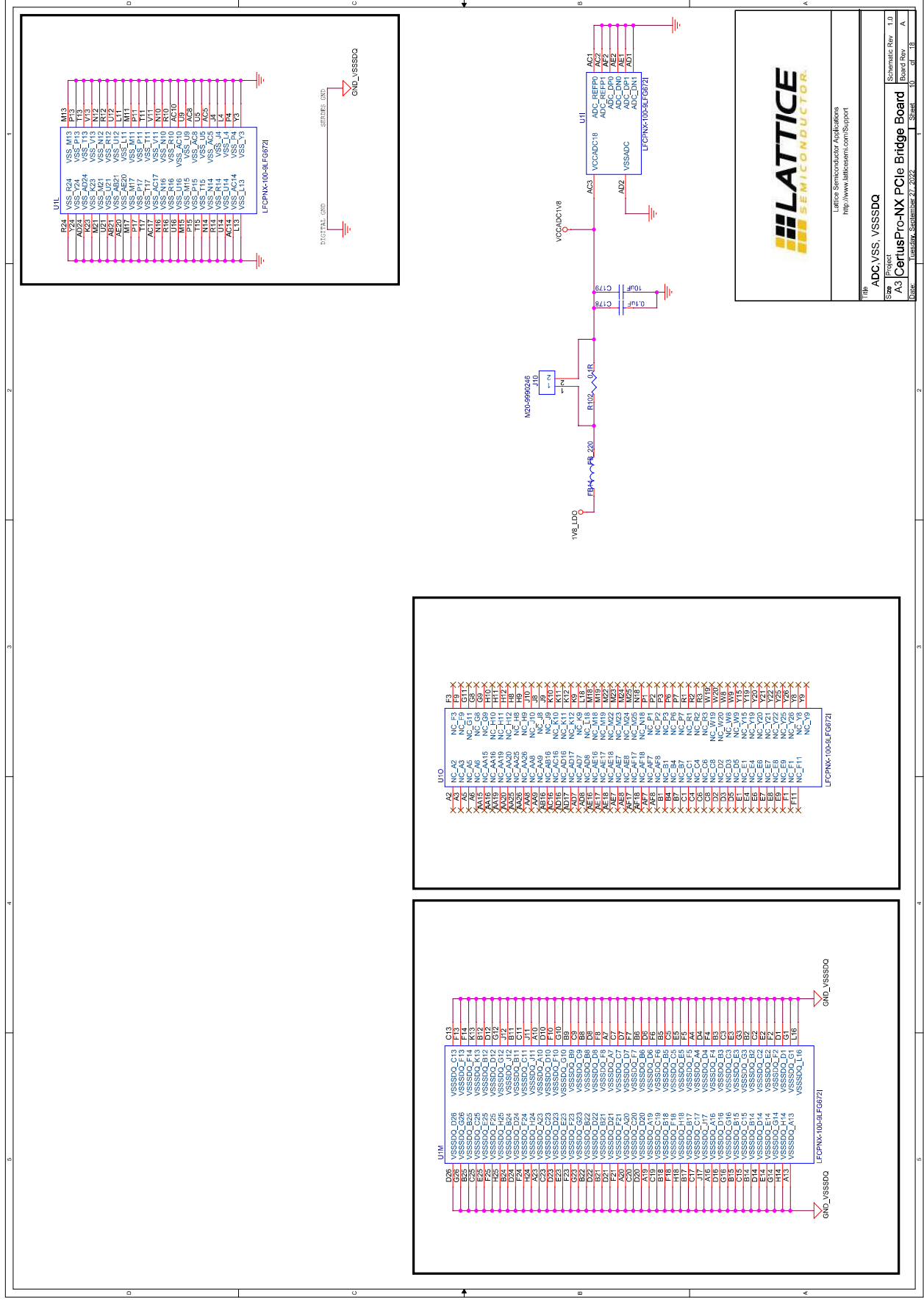

Figure A. 10. ADC, VSS, VSSDDQ

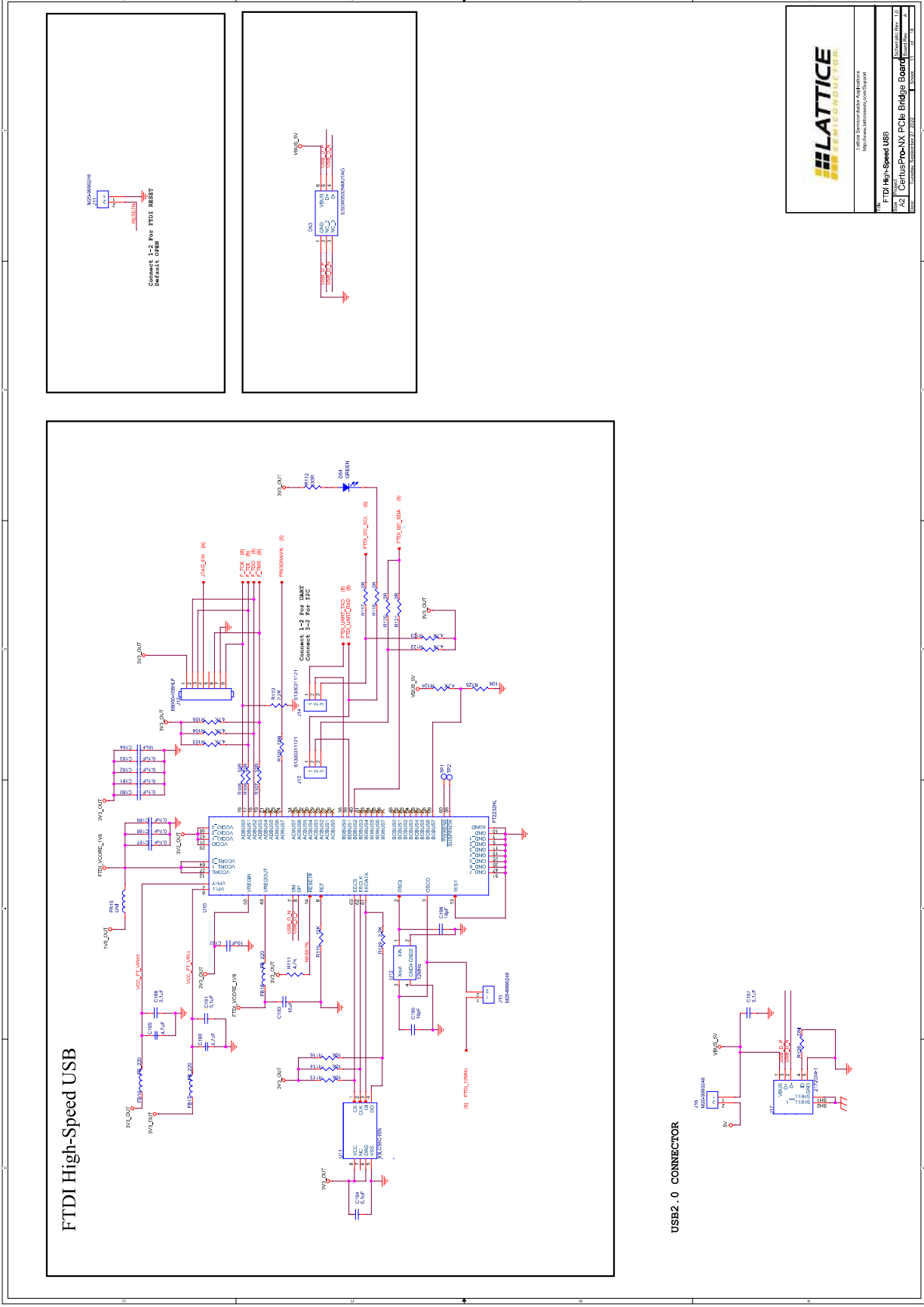

Figure A. 11. FTDI High-Speed USB

© 2022 Lattice Semiconductor Corp. All Lattice trademarks, registered trademarks, patents, and disclaimers are as listed at www.latticesemi.com/legal. All other brand or product names are trademarks or registered trademarks of their respective holders. The specifications and information herein are subject to change without notice.

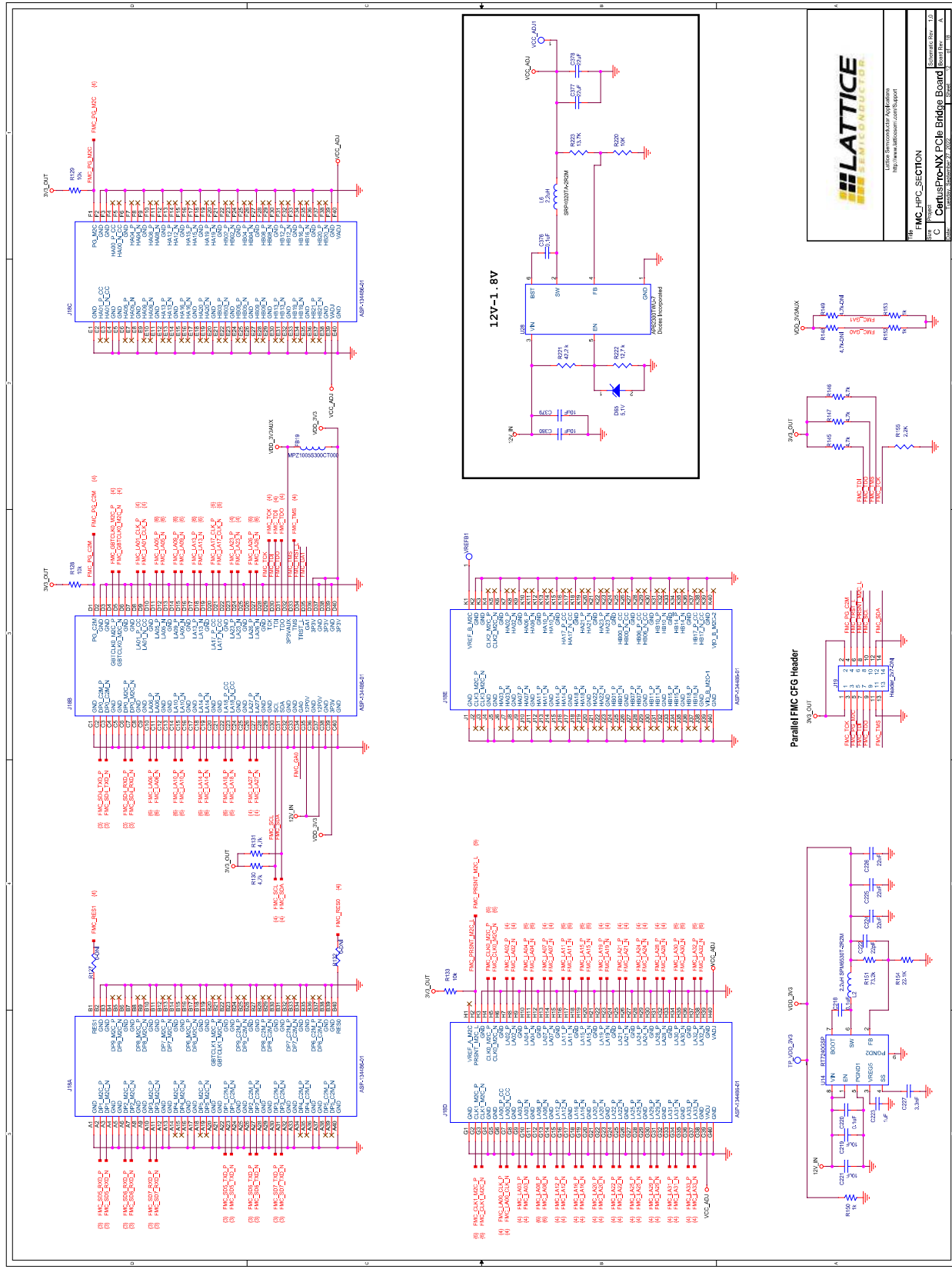

Figure A. 12. FMC_HPC_SECTION

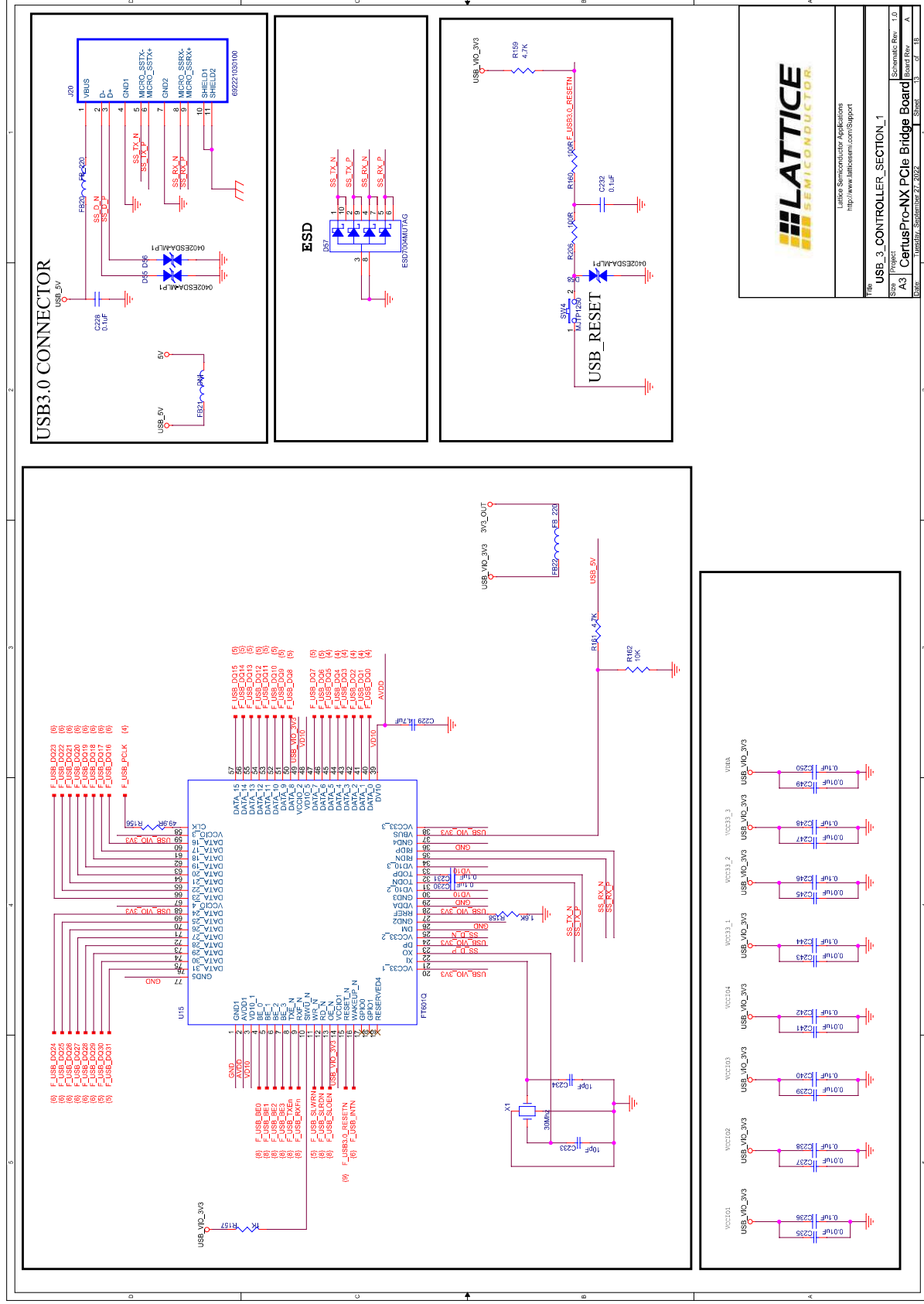
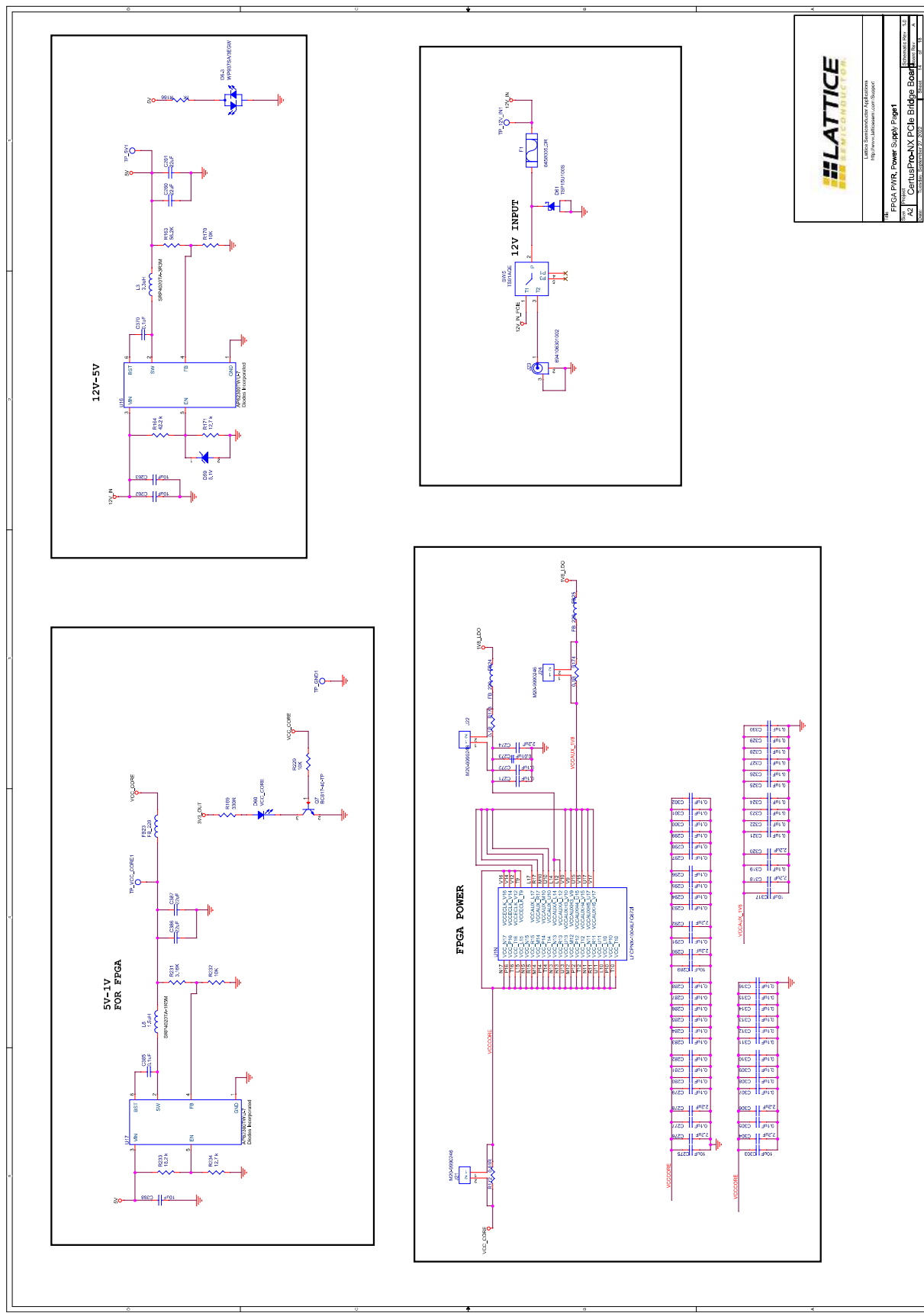

Figure A. 13. USB_3_CONTROLLER_SECTION_1

© 2022 Lattice Semiconductor Corp. All Lattice trademarks, registered trademarks, patents, and disclaimers are as listed at www.latticesemi.com/legal. All other brand or product names are trademarks or registered trademarks of their respective holders. The specifications and information herein are subject to change without notice.



Lattice Semiconductor AG Location
http://www.lattice.com/locate

FPGA PWR, Power Supply Page1

Doc # 70000
AZ CertusPro-NX PCIe Bridge Board

Figure A. 14. FPGA PWR, Power Supply Page1

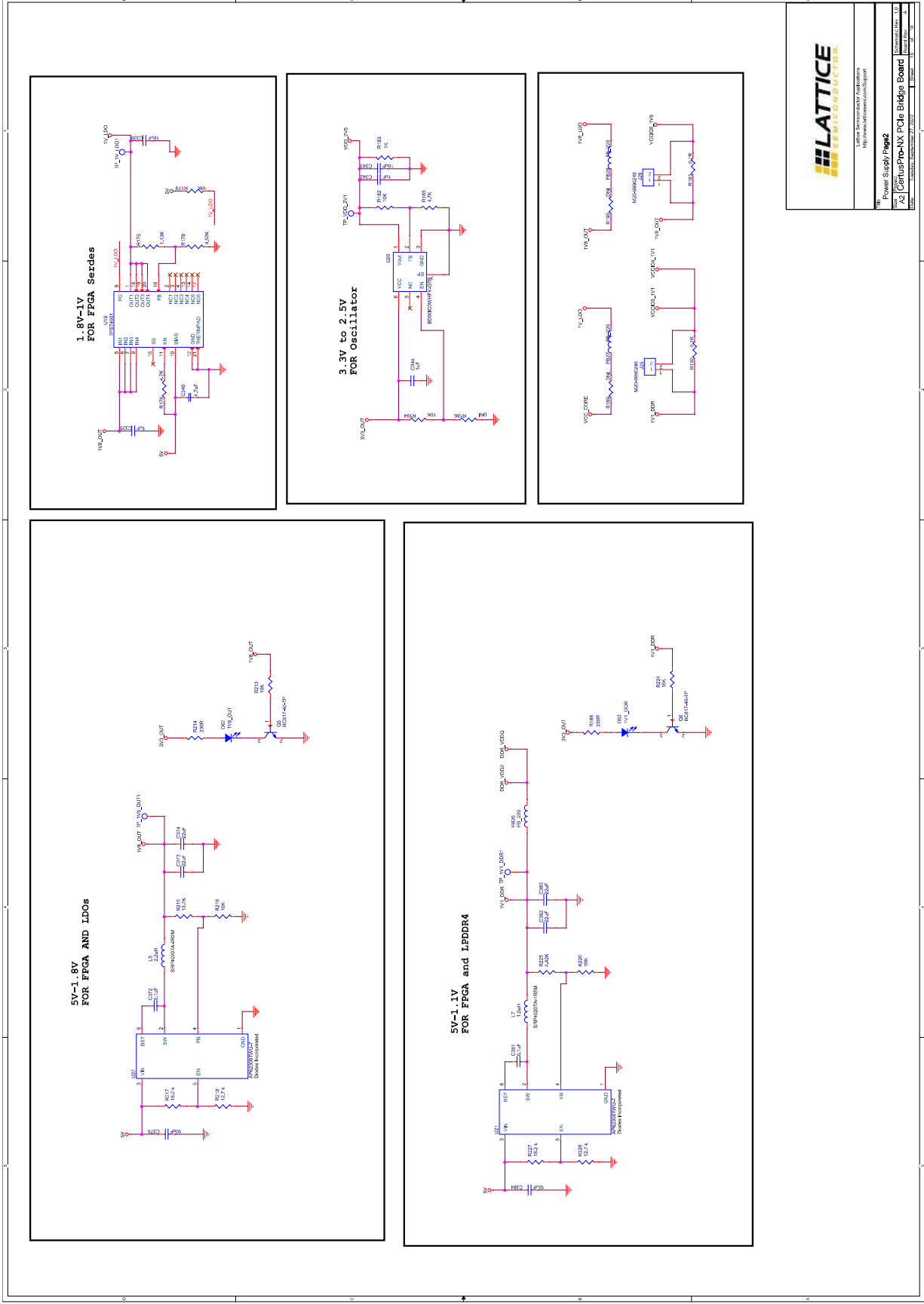

Lattice Semiconductor Applications
http://www.lattice.com/support

18
19
20
21
22
23
24
25
26
27
28
29
30
31
32
33
34
35
36
37
38
39
40
41
42
43
44
45
46
47
48
49
50
51
52
53
54
55
56
57
58
59
60
61
62
63
64
65
66
67
68
69
70
71
72
73
74
75
76
77
78
79
80
81
82
83
84
85
86
87
88
89
90
91
92
93
94
95
96
97
98
99
100

18
19
20
21
22
23
24
25
26
27
28
29
30
31
32
33
34
35
36
37
38
39
40
41
42
43
44
45
46
47
48
49
50
51
52
53
54
55
56
57
58
59
60
61
62
63
64
65
66
67
68
69
70
71
72
73
74
75
76
77
78
79
80
81
82
83
84
85
86
87
88
89
90
91
92
93
94
95
96
97
98
99
100

18
19
20
21
22
23
24
25
26
27
28
29
30
31
32
33
34
35
36
37
38
39
40
41
42
43
44
45
46
47
48
49
50
51
52
53
54
55
56
57
58
59
60
61
62
63
64
65
66
67
68
69
70
71
72
73
74
75
76
77
78
79
80
81
82
83
84
85
86
87
88
89
90
91
92
93
94
95
96
97
98
99
100

Figure A. 15. Power Supply Page 2

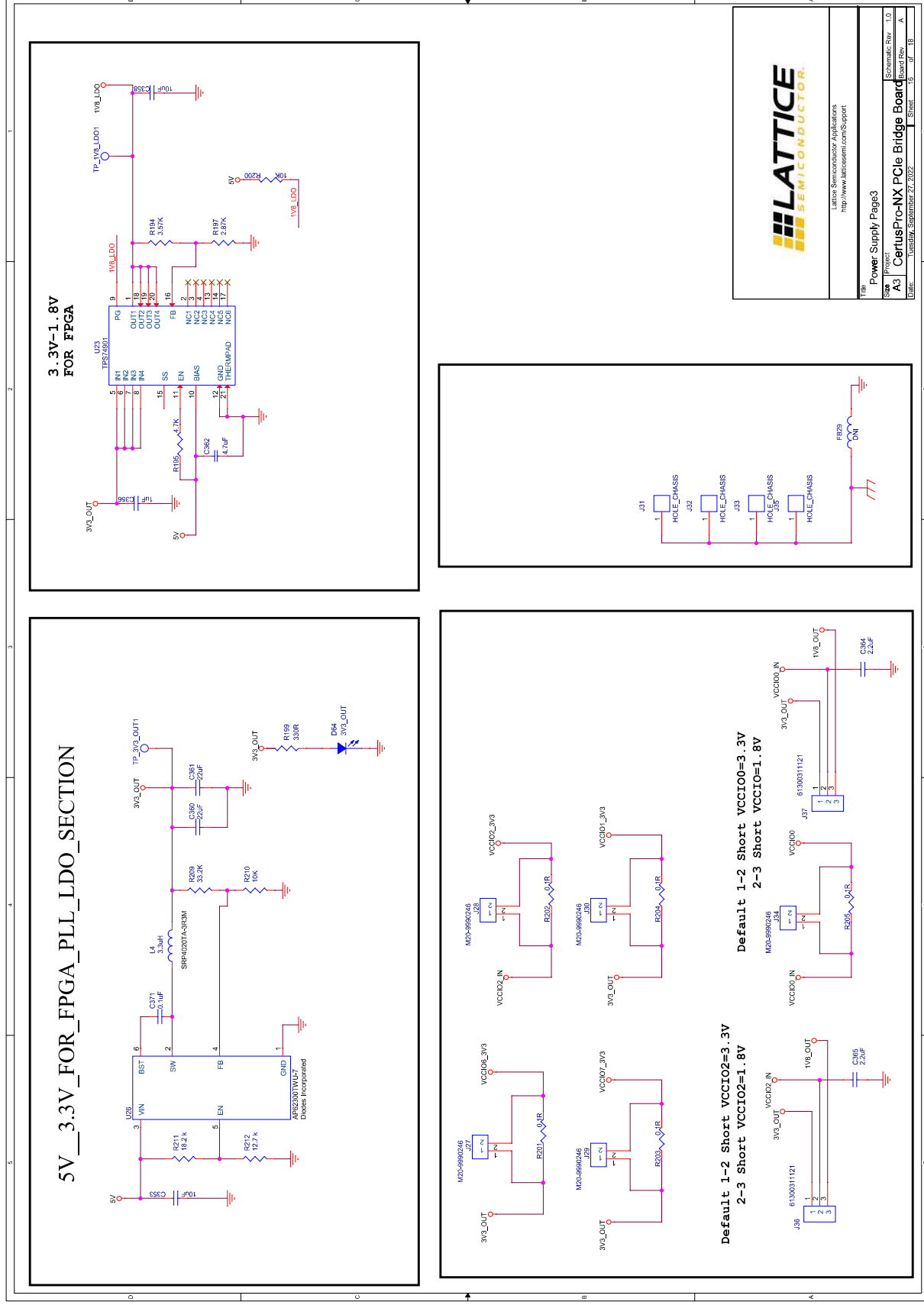

Figure A. 16. Power Supply Page3

Lattice Semiconductor Applications
http://www.latticesemi.com/support

Title	Power Supply Page3
Project	CertusPro-NX PCIe Bridge Board
Sheet	10 of 18
Version	1.0
Date	September 27, 2022

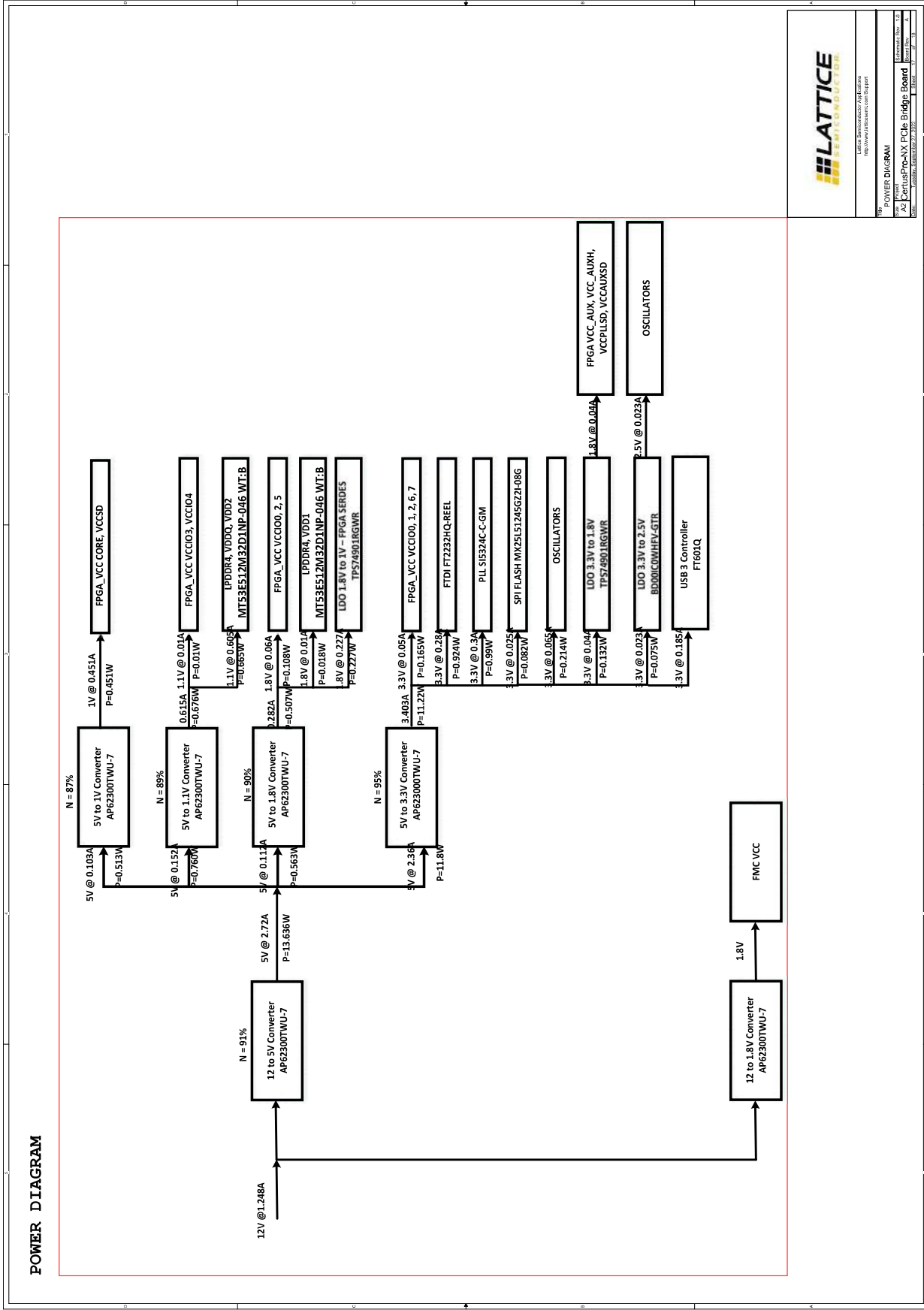

Figure A. 17. CLOCK DIAGRAM

© 2022 Lattice Semiconductor Corp. All Lattice trademarks, registered trademarks, patents, and disclaimers are as listed at www.latticesemi.com/legal. All other brand or product names are trademarks or registered trademarks of their respective holders. The specifications and information herein are subject to change without notice.

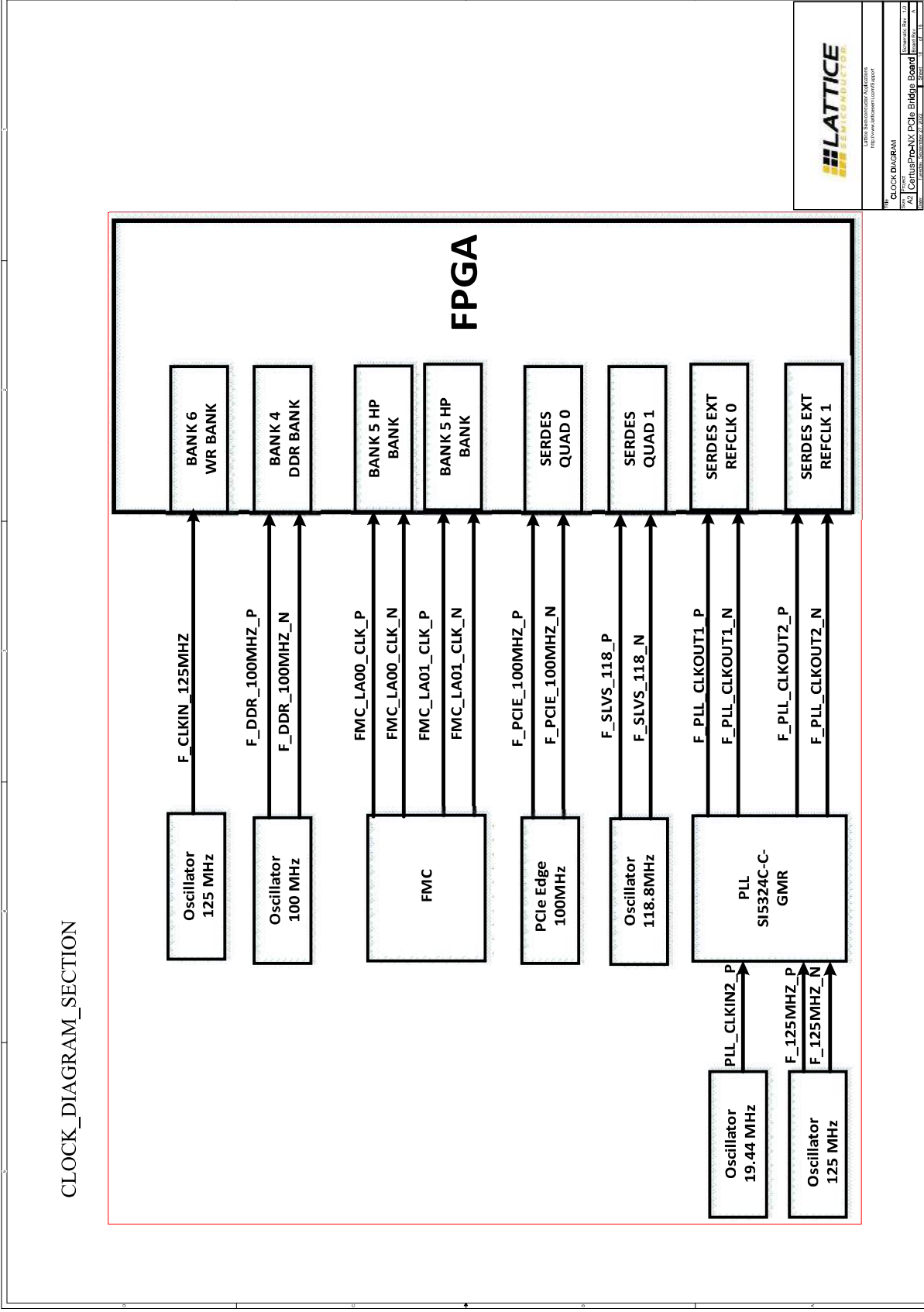

Figure A. 18. CLOCK DIAGRAM

Appendix B. CertusPro-NX PCIe Bridge Board Bill of Materials

Item	Reference	Qty	Value	PCB Footprint	Comments	Part Number	Manufacturer	Description
1	CN1	1	PCIe_X4_EdgeConn	pcie_64_pin	DNL	-	-	-
2	C1,C7,C13,C25,C29,C31,C3 3,C35,C37,C39,C41,C43,C4 5,C47,C49,C51,C55,C56,C5 7,C58,C59,C60,C61,C62,C6 3,C65,C66,C67,C68,C69,C7 0,C71,C72,C73,C74,C75,C7 8,C79,C80,C83,C85,C86,C8 9,C92,C95,C97,C98,C101,C 102,C103,C104,C107,C108, C109,C112,C113,C115,C11 9,C120,C121,C122,C123,C1 24,C125,C129,C130,C131,C 132,C133,C134,C135,C136, C137,C138,C139,C140,C14 1,C145,C146,C147,C148,C1 49,C150,C151,C152,C153,C 154,C155,C157,C158,C162, C163,C164,C165,C166,C16 8,C170,C171,C172,C173,C1 75,C178,C180,C181,C182,C 183,C186,C187,C188,C189, C191,C228,C230,C231,C23 2,C236,C238,C240,C242,C2 44,C246,C248,C250,C271,C 272,C277,C279,C280,C281, C282,C283,C284,C285,C28 6,C287,C288,C291,C293,C2 94,C295,C296,C297,C298,C 299,C300,C301,C302,C305, C307,C308,C309,C310,C31 1,C312,C313,C314,C315,C3 16,C319,C321,C322,C323,C 324,C325,C326,C327,C328, C329,C330,C366,C367,C36 8,C370,C371,C372,C376,C3 81,C385	178	0.1uF	cap0402	-	GRM155R71H104KE14J	Murata Electronics	CAP CER 0.1UF 50V X7R 0402
3	C2,C8,C16,C26,C30,C32,C3 4,C36,C38,C40,C42,C44,C4 6,C48,C50,C52	16	10uF	cap0402	-	CL05A106MP5NUNC	Samsung Electro- Mechanics	CAP CER 10UF 10V X5R 0402
4	C3,C4,C9,C11,C14,C17,C23 ,C24	8	0.22uF	cap0201	-	C0603X5R1E224K030BC	TDK Corporation	CAP CER 0.22UF 25V X5R 0201
5	C5,C6,C10,C12,C15,C18,C1 9,C20,C21,C22,C27,C28	12	0.22uF	cap0402	-	TMK105B7224KV-FR	Taiyo Yuden	CAP CER 0.22UF 25V X7R 0402

© 2022 Lattice Semiconductor Corp. All Lattice trademarks, registered trademarks, patents, and disclaimers are as listed at www.latticesemi.com/legal. All other brand or product names are trademarks or registered trademarks of their respective holders. The specifications and information herein are subject to change without notice.

Item	Reference	Qty	Value	PCB Footprint	Comments	Part Number	Manufacturer	Description
6	C53,C54,C64,C76,C81,C82,C87,C90,C91,C96,C99,C105,C106,C110,C118,C128,C144,C156,C159,C160,C167,C169,C179,C184,C192,C193,C275,C289,C303,C317,C339,C343,C358	33	10uF	cap0603	-	CM105X5R106M25AT	Kyocera International Inc. Electronic Components	CAP CER 10UF 25V X5R 0603
7	C77,C84,C94,C114,C235,C237,C239,C241,C243,C245,C247,C249,C273	13	0.01uF	cap0603	-	CC0603KRX7R9BB103	Yageo	CAP CER 10000PF 50V X7R 0603
8	C88,C100,C174,C274,C276,C278,C290,C292,C304,C306,C318,C320,C364,C365	14	2.2uF	cap0402	-	GRM155C81E2225KE11D	Murata Electronics	CAP CER 2.2UF 25V X6S 0402
9	C93	1	DNI	cap0603	DNL	-	-	-
10	C111	1	10uF	cap0402	-	CL05A106MP5NUNC	Samsung Electro-Mechanics	CAP CER 10UF 10V X5R 0402
11	C116,C117,C126,C127,C142,C143,C185,C190,C229,C340,C362	11	4.7uF	cap0402	-	CL05A475KP5NRNC	Samsung Electro-Mechanics	CAP CER 4.7UF 10V X5R 0402
12	C161,C335,C342,C344,C356	5	1uF	cap0603	-	GRT188R61H105KE13D	Murata Electronics	CAP CER 1UF 50V X5R 0603
13	C176,C195,C196	3	18pF	cap0402	-	CC0402JRNPO9BN180	Yageo	CAP CER 18PF 50V COG/NPO 0402
14	C177	1	18 pF	cap0402	-	CC0402JRNPO9BN180	Yageo	CAP CER 18PF 50V COG/NPO 0402
15	C194,C197	2	0.1uF	cap0603	-	CC0603ZRY5V9BB104	Yageo	CAP CER 0.1UF 50V Y5V 0603
16	C218,C220	2	0.1uF	C0201	-	GRM033R61E104KE14J	Murata	CAP CER 0.1UF 25V 10% X5R 0201
17	C219,C221	2	10uF	C1206	-	CL31A106MBHNNNE	Samsung Electro-Mechanics	CAP CER 10UF 50V X5R 1206
18	C222	1	22pF	C0603	-	CC0603JRNPO9BN220	Yageo	CAP CER 22PF 50V COG/NPO 0603
19	C223	1	1uF	C0603	-	TMK107B7105KA-T	Taiyo Yuden	CAP CER 1UF 25V 10% X7R 0603
20	C224,C225,C226,C260,C261,C360,C361,C373,C374,C377,C378,C382,C383,C386,C387	15	22uF	C0603	-	GRM188R61A226ME15D	Murata	CAP CER 22UF 10V X5R 0603
21	C227	1	3.3nF	C0201	-	GRM033R71E332KA12D	Murata	CAP CER 3300PF 25V X7R 0201
22	C233,C234	2	10pF	cap0603	-	CC0603JRNPO9BN100	Yageo	CAP CER 10PF 50V COG/NPO 0603
23	C262,C263,C353,C375,C379,C380,C384,C388	8	10uF	cap0805	-	C2012X5R1E106M085AC	TDK Corporation	CAP CER 10UF 25V X5R 0805

Item	Reference	Qty	Value	PCB Footprint	Comments	Part Number	Manufacturer	Description
24	C369	1	1uF	cap0402	-	GRM155R70J105MA12D	Murata	CAP CER 1UF 6.3V X7R 0402
25	D1,D2,D3,D4,D5,D8,D9,D10,D11,D12,D13,D14,D15,D16,D17,D18,D19,D20,D21,D22,D23,D24,D25,D26,D27,D28,D29,D30,D31,D32,D33,D34,D36,D45,D46,D47,D48,D49,D50,D51,D52,D55,D56,D58	44	DIODE_SUPPRESSOR ESD 30VDC 0402	ESD0402	-	0402ESDA-M1P1	Eaton - Electronics Division	SUPPRESSOR ESD 30VDC 0402 HFREE
26	D6	1	WP937SA/3EGW	LED_CBI	-	WP937SA/3EGW	Kingbright	REDGREEN TRI-LEVEL LED INDICATOR
27	D7,D37,D38,D39,D40,D41,D42,D43,D44,D54	10	GREEN	led_0603	-	SML-D12M8WT86	Rohm Semiconductor	LED GREEN DIFFUSED 0603 SMD
28	D35	1	LDT-NZ804RI	display_12P-PTH	-	LDT-NZ804RI	Lumex Opto/Components Inc.	DISPLAY 7SEG 0.28" TRP RED 12DIP
29	D53	1	ESDR0502NMUTAG	UDFN-6	-	ESDR0502NMUTAG	ON Semiconductor	TVS DIODE 5.5V 6UDFN
30	D57	1	ESD7004MUTAG	10UDFN_10P	-	ESD7004MUTAG	ON Semiconductor	TVS DIODE 5V 10V 10UDFN
31	D59,D65	2	5.1V	SOD323_BZX384	-	BZX384-CSV1,115	Nexperia USA Inc.	DIODE ZENER 5.1V 300MW SOD323
32	D60	1	VCC_CORE	led_0603	-	SML-D12M8WT86	Rohm Semiconductor	LED GREEN DIFFUSED 0603 SMD
33	D61	1	TSP15U100S	TO277A_TSP15U100S	-	TSP15U100S	Taiwan Semiconductor Corp	DIODE SCHOTTKY 100V 15A TO277A
34	D62	1	1V8_OUT	led_0603	-	SML-D12M8WT86	Rohm Semiconductor	LED GREEN DIFFUSED 0603 SMD
35	D63	1	1V1_DDR	led_0603	-	SML-D12M8WT86	Rohm Semiconductor	LED GREEN DIFFUSED 0603 SMD
36	D64	1	3V3_OUT	led_0603	-	SML-D12M8WT86	Rohm Semiconductor	LED GREEN DIFFUSED 0603 SMD
37	FB1,FB2,FB3,FB4,FB5,FB6,FB7,FB8,FB9,FB10,FB11,FB12,FB13,FB14,FB16,FB17,FB18,FB20,FB22,FB23,FB24,FB25,FB26,FB27,FB28	25	FB_220	FB0603	-	BLM18SP221SZ1D	Murata Electronics	FERRITE BEAD 220 OHM 0603 1LN
38	FB15,FB21,FB29	3	DNI	FB0603	DNL	-	-	-
39	FB19	1	MPZ1005S300CT000	FB0402	-	MPZ1005S300CT000	TDK Corporation	FERRITE BEAD 30 OHM 0402 1LN
40	F1	1	0458005.DR	fus1206	-	0458005.DR	Littelfuse Inc.	FUSE BRD MNT 5A 32VAC 75VDC 1206

Item	Reference	Qty	Value	PCB Footprint	Comments	Part Number	Manufacturer	Description
41	J1,J2,J3,J10,J11,J15,J16,J21,J22,J24,J25,J26,J27,J28,J29,J30,J34	17	M20-9990246	hdr_1x2	-	M20-9990246	Harwin Inc.	CONN HEADER VERT 2POS 2.54MM
42	J4	1	613006211121	conn_header_6_pos	Default : Pin 2&4	613006211121	Würth Elektronik	CONN HEADER VERT 6POS 2.54MM
43	J5	1	JUMPER	HDR_1X2	-	613002111121	Würth Elektronik	Headers & Wire Housings WR-PHD 2.54mm 2Pin THT Header
44	J6,J9	2	M20-9980746	14pin_bergstick	-	M20-9980746	Harwin Inc.	CONN HEADER VERT 14POS 2.54MM
45	J7,J8	2	PPPC062LJBN-RC	conn_pppc062ljb_n-rc_RA	-	PPPC062LJBN-RC	Sullins Connector Solutions	CONN HDR 12POS 0.1 GOLD PCB R/A
46	J12	1	68000-408HLF	8PINSTICK	-	68000-408HLF	Amphenol FCI	CONN HEADER 8POS .100 STR TIN
47	J13,J14	2	613003111121	conn_header_3_pos	-	613003111121	Würth Electronics Inc.	CONN HEADER VERT 3POS 2.54MM
48	J36,J37	2	613003111121	conn_header_3_pos	Default : Pin 1&2	613003111121	Würth Electronics Inc.	CONN HEADER VERT 3POS 2.54MM
49	J17	1	2172034-1	2172034-1	-	2172034-1	TE Connectivity AMP Connectors	CONN RCPT USB2.0 MINI B 5P R/A
50	J18	1	ASP-134486-01	ASP-134486-01	-	ASP-134486-01	Samtec Inc.	CONN ARRAY RCPT 400POS SMD GOLD
51	J19	1	Header_2x7-DNI	Header_2x7	DNL	-	-	-
52	J20	1	692221030100	692221030100_USB3P0	-	692221030100	Würth Elektronik	CONN RCPT USB3.0 TYPEB 9POS R/A
53	J23	1	694106301002	694106301002	-	694106301002	Würth Elektronik	CONN PWR JACK 2.1X5.5MM SOLDER
54	J31,J32,J33,J35	4	HOLE_CHASIS	hole35mmhead	DNL	-	-	-
55	L2	1	2.2uH SPM6530T-2R2M	SPM6530T-2R2M	-	SPM6530T-2R2M	TDK Corporation	FIXED IND 2.2UH 8.2A 19 MOHM SMD
56	L3,L4	2	3.3uH	SRP4020TA-3R3M	-	SRP4020TA-3R3M	Bourns Inc.	FIXED IND 3.3UH 3.5A 76 MOHM SMD
57	L5,L6	2	2.2uH	SRP4020TA-2R2M	-	SRP4020TA-2R2M	Bourns Inc.	FIXED IND 2.2UH 4A 61 MOHM SMD
58	L7,L8	2	1.5uH	SRP4020TA-1R5M	-	SRP4020TA-1R5M	Bourns Inc.	FIXED IND 1.5UH 4.5A 42 MOHM SMD
59	Q1,Q2,Q3,Q4,Q5,Q6,Q7	7	BC817-40-TP	SOT23-3	-	BC817-40-TP	Micro Commercial Co	TRANS NPN 45V 0.8A SOT-23
60	R1,R2,R3,R4	4	976R	res0402	-	RP73PF1E976RBTD	TE Connectivity Passive Product	RES 976 OHM 0.1% 1/10W 0402
61	R5,R6	2	DNI	res0201	DNL	-	-	-
62	R7,R8,R9,R10	4	1.15K	res0402	-	CPF0402B1K15E1	TE Connectivity Passive Product	RES SMD 1.15KOHM 0.1% 1/16W 0402

Item	Reference	Qty	Value	PCB Footprint	Comments	Part Number	Manufacturer	Description
63	R11,R12,R56	3	100	res0201	-	CRCW0201100RFKED	Vishay Dale	RES SMD 100 OHM 1% 1/20W 0201
64	R13,R14,R20,R102,R173,R 174,R192,R193,R201,R202, R203,R204,R205	13	0.1R	res0603	-	ERJ-3RSFR10V	Panasonic Electronic Components	RES 0.1 OHM 1% 1/10W 0603
65	R15,R16,R17,R18,R23,R24, R25,R26,R27,R28,R30,R41, R45,R50,R58,R59,R65,R86, R90,R92,R94,R95,R96,R10 3,R104,R105,R111,R122,R 123,R124,R159,R161,R176, R185,R195	35	4.7K	res0603	-	RC0603JR-074K7L	Yageo	RES SMD 4.7K OHM 5% 1/10W 0603
66	R19,R33,R34,R35,R36,R37, R38,R39,R117,R118,R120, R121	12	0R	res0603	-	ERJ-3GEY0R00V	Panasonic Electronic Components	RES SMD 0 OHM JUMPER 1/10W 0603
67	R21,R78,R100,R106,R107, R108	6	33R	res0402	-	ERJ-2GEI330X	Panasonic Electronic Components	RES SMD 33 OHM 5% 1/10W 0402
68	R22,R57	2	DNI	res0402	DNL	-	-	-
69	R29,R32,R43,R44,R46,R47, R48,R49,R126,R189,R190	11	DNI	res0603	DNL	-	-	-
70	R31,R79,R80,R81,R82,R83, R84,R85,R87,R88,R89,R91, R101,R112,R169,R188,R19 9,R214	18	330R	res0603	-	ERJ-3EKF3300V	Panasonic Electronic Components	RES SMD 330 OHM 1% 1/10W 0603
71	R40,R42,R75,R113,R114,R 116,R125,R162,R179,R182, R184,R200,R213,R224,R22 9	15	10K	res0603	-	RC1608F103CS	Samsung Electro- Mechanics	RES SMD 10K OHM 1% 1/10W 0603
72	R51,R54,R55,R76,R93,R16 0,R206	7	100R	res0402	-	ERJ-2RKF1000X	Panasonic Electronic Components	RES SMD 100 OHM 1% 1/10W 0402
73	R52,R53,R109	3	DNI	res0603	DNL	-	-	-
74	R60,R61,R97,R98,R99	5	DNI	res0603	DNL	-	-	-
75	R62,R63	2	158R	res0201	-	RC0201FR-07158RL	Yageo	RES SMD 158 OHM 1% 1/20W 0201
76	R64	1	240R	res_0402	-	ERJ-2RKF2400X	Panasonic Electronic Components	RES SMD 240 OHM 1% 1/10W 0402
77	R66	1	DNI	res_0402	DNL	-	-	-
78	R67,R68,R69,R70,R71,R72, R73,R74	8	53.6R	res0402	-	RC0402FR-0753R6L	Yageo	RES SMD 53.6 OHM 1% 1/16W 0402
79	R77,R157,R166,R183	4	1K	res0603	-	CPF0603F1K0C1	TE Connectivity Passive Product	RES SMD 1K OHM 1% 1/16W 0603

Item	Reference	Qty	Value	PCB Footprint	Comments	Part Number	Manufacturer	Description
80	R110,R119	2	2.2K	res0603	-	ERJ-3EKF2201V	Panasonic Electronic Components	RES SMD 2.2K OHM 1% 1/10W 0603
81	R115	1	12K	res0603	-	RC0603FR-0712KL	Yageo	RES SMD 12K OHM 1% 1/10W 0603
82	R127,R132	2	0-DNI	R0603	DNL	-	-	-
83	R128,R129,R133	3	10k	R0603	-	RC0603FR-0710KL	YAGEO	RES SMD 10K OHM 1% 1/10W 0603
84	R130	1	4.7k	R0603	-	RC0603FR-074K7L	YAGEO	RES SMD 4.7K OHM 1% 1/10W 0603
85	R131,R145,R146,R147	4	4.7k	R0603	-	RC0603FR-074K7L	YAGEO	RES SMD 4.7K OHM 1% 1/10W 0603
86	R148,R149	2	4.7k-DNI	R0603	DNL	-	-	-
87	R150,R152,R153	3	1k	R0603	-	CPF0603F1K0C1	TE Connectivity Passive Product	RES SMD 1K OHM 1% 1/16W 0603
88	R151	1	73.2k	R0603	-	ERJ-3EKF7322V	Panasonic	RES SMD 73.2K OHM 1% 1/10W 0603
89	R154	1	22.1K	R0603	-	RC0603FR-1322K1L	YAGEO	RES 22.1K OHM 1% 1/10W 0603
90	R155	1	2.2K	R0603	-	ERJ-3EKF2201V	Panasonic Electronic Components	RES SMD 2.2K OHM 1% 1/10W 0603
91	R156	1	49.9R	res0402	-	CRCW040249R9FKEDHP	Vishay Dale	RES SMD 49.9 OHM 1% 1/5W 0402
92	R158	1	1.6K	RES0402	-	RC0402FR-071K6L	Yageo	RES SMD 1.6K OHM 1% 1/16W 0402
93	R163	1	56.2K	res0603	-	RE0603FRE0756K2L	Yageo	RES SMD 56.2K OHM 1% 1/10W 0603
94	R164,R221	2	42.2 k	res0402	-	ERA-2AEB4222X	Panasonic Electronic Components	RES SMD 42.2KOHM 0.1% 1/16W 0402
95	R170,R210,R216,R220,R22	6	10K	res0603	-	RC0603FR-0710KL	Yageo	RES 10K OHM 1% 1/10W 0603
96	R171,R212,R218,R222,R22	6	12.7 k	res0402	-	ERJ-2RKF1272X	Panasonic Electronic Components	RES SMD 12.7K OHM 1% 1/10W 0402
97	R172	1	0.01R	res0603	-	RL0603FR-070R01L	Yageo	RES 0.01 OHM 1% 1/10W 0603
98	R175	1	1.13K	res0402	-	ERA-2AEB1131X	Panasonic Electronic Components	RES SMD 1.13KOHM 0.1% 1/16W 0402
99	R178	1	4.53K	res0402	-	ERJ-2RKF4531X	Panasonic Electronic Components	RES SMD 4.53K OHM 1% 1/10W 0402

Item	Reference	Qty	Value	PCB Footprint	Comments	Part Number	Manufacturer	Description
100	R186	1	DNI	res0603	DNL	-	-	-
101	R194	1	3.57K	res0402	-	ERJ-2RKF3571X	Panasonic Electronic Components	RES SMD 3.57K OHM 1% 1/10W 0402
102	R197	1	2.87K	res0402	-	CRCW04022K87FKED	Vishay Dale	RES SMD 2.87K OHM 1% 1/16W 0402
103	R235,R236	2	1k	res0402	-	RC0402FR-071KL	Yageo	RES 1K OHM 1% 1/16W 0402
104	R209	1	33.2K	res0603	-	RC0603FR-0733K2L	Yageo	RES SMD 33.2K OHM 1% 1/10W 0603
105	R211,R217,R227,R233	4	18.2 k	res0402	-	RT0402BRD0718K2L	YAGEO	RES SMD 18.2KOHM 0.1% 1/16W 0402
106	R215,R223	2	13.7K	res0603	-	RC0603FR-0713K7L	Yageo	RES 13.7K OHM 1% 1/10W 0603
107	R225	1	4.42K	res0603	-	RC0603FR-074K42L	Yageo	RES 4.42K OHM 1% 1/10W 0603
108	R231	1	3.16K	res0603	-	RC0603FR-073K16L	Yageo	RES 3.16K OHM 1% 1/10W 0603
109	SW1	1	SW_SPST	sw_spst-05_smd	-	219-5LPST	CTS Electrocomponents	SWITCH SLIDE DIP SPST 100MA 20V
110	SW2,SW3,SW4	3	MJTP1250	SW_TH2	-	MJTP1250	APEM Inc.	SWITCH TACTILE SPST-NO 0.05A 12V
111	SW5	1	TS01AQE	sw_500SSP1S1M6QEA	-	500SSP1S1M6QEA	E-Switch	SWITCH SLIDE SPDT 5A 120V
112	TP_VCC_CORE1,TP_INITN1,TP_GND1,TP_DONE1,TP1,TP2,TP_1V_LDO1,TP_VDD_2V1,TP_5V1,TP_1V1_DDR_1,TP_12V_IN1,TP_1V8_OU T1,TP_1V8_LDO1,TP_3V3_PClE1,TP_3V3_OUT1	15	VTTVREF	TP_50	DNL	-	-	-
113	VREFB1,VCC_ADJ1,TP_VD D_3V3	3	TP_S_40_63	tp_s_40_63	DNL	-	-	-
114	U1	1	LFCPNX-100-9LFG672I	FPGA-672	Customer Supplied	LFCPNX-100-9LFG672I	Lattice	Jedi-D1 family of low-power general purpose FPGAs featuring 10G SerDes,
115	U2	1	125MHz	osc_32x25_4pin_25mhz	-	SX032C3A071-125.000M	Suntsu Electronics, Inc.	XTAL OSC XO 125.00000MHZ CMOS SMD
116	U3	1	125MHz	SG3225VEN_125p000000M-DJHA3	-	SG3225VEN 125.000000M-DJHA3	EPSON	XTAL OSC XO 125MHZ 2.5V LVDS
117	U4	1	MX25L51245GZ2I-08G	8-WSON	-	MX25L51245GZ2I-08G	Macronix	IC FLASH 512MBIT SPI/QUAD 8WSON
118	U5	1	100MHz	SG5032VAN_100p000000M-KEGA3	-	SG5032VAN 100.000000M-KEGA3	EPSON	XTAL OSC XO 100.00000MHZ LVDS SMD

Item	Reference	Qty	Value	PCB Footprint	Comments	Part Number	Manufacturer	Description
119	U6	1	MT53E512M32D1NP-046 WT:B	BGA_SDRAM_2 00	-	MT53E512M32D1NP-046 WT:B	Micron Technology Inc.	IC MEMORY DRAM 16G 512MX32 FBGA
120	U7	1	S15324C	QFN36_S15324 C-C-GM	-	S15324C-C-GM	Skyworks Solutions	Clock Synthesizer/Jitter Cleaner Any-frequency jitter attenuating clock
121	U8	1	114.285MHZ	osc_CS-023- 114p285M	-	CS-023-114.285M	Connor-Winfield	CRYSTAL 114.2850MHZ 18PF SMD
122	U9	1	FOX924B-19.44	osc_5x3p2	-	FT5HNBPK19.44-T1	Fox Electronics	OSC TCXO 19.44MHZ HCMOS SMD
123	U10	1	FT2232HL	LQFP64_FT223 2HL	Customer Supplied	FT2232HL-REEL	FTDI, Future Technology Devices International Ltd	IC USB HS DUAL UART/FIFO 64-LQFP
124	U11	1	93LC56C-1SN	soic_8_150mil	-	93LC56C-I/SN	Microchip Technology	EEPROM Memory IC 2Kb _256 x 8, 128 x 16_ SPI 3MHz 8-SOIC
125	U12	1	12MHz	XTAL_7V- 12p000MDDJ-T	-	7V-12.000MDDJ-T	TXC CORPORATION	CRYSTAL 12.0000MHZ 18PF SMD
126	U14	1	RT7240GSP	SOP_8_RT7240 GSP	-	RT7240GSP	Richtek USA Inc.	IC REG BUCK ADJUSTABLE 5A 8SOP
127	U15	1	FT601Q	QFN76_FT601Q	-	FT601Q-B	FTDI	IC USB3-32BIT SYNC FIFO 76QFN
128	U16,U17,U21,U26,U27,U2 8	6	AP62300TWU-7	TSOT26_AP623 00TWU-7	-	AP62300TWU-7	Diodes Incorporated	DCDC CONV HV BUCK,TSOT26,T&R,3K
129	U19,U23	2	TPS74901	vqfn_20	-	TPS74901RGWR	Texas Instruments	IC REG LINEAR POS ADJ 3A 20VQFN
130	U20	1	BD001COWHFV-GTR	6-HVSOF	-	BD001COWHFV-GTR	Rohm Semiconductor	IC REG LINEAR POS ADJ 1A 6HVSOF
131	U24	1	NX33B8801Z	NX33B8801Z	Customer Supplied	NX33B8801Z	Diodes Incorporated	CRYSTAL OSCILLATOR SEAM3225 T&R
132	U25	1	TXB0104QPWRQ1	TSSOP14_TXB0 104	-	TXB0104QPWRQ1	Texas Instruments	IC TRNSLTR BIDIRECTIONAL 14TSSOP
133	X1	1	30Mhz	XTAL_ABM8	-	ABM8-30.000MHZ-10-1-U-T	Abracon LLC	CRYSTAL 30.0000MHZ 10PF SMD
134	Shunts for Headers	3			-	SPC02SVAN	Sullins	CONN JUMPER SHORTING GOLD FLASH
135	CERTUSPRO NX PCIe BRIDGE BOARD PCB REVA	1			-	305-PD-22-0445	PACTRON	

Technical Support Assistance

Submit a technical support case through www.latticesemi.com/techsupport.

Revision History

Revision 1.0, October 2022

Section	Change Summary
All	Initial release



www.latticesemi.com