

LOC	DIST	REVISIONS					
CM	00	P	LTB	DESCRIPTION	DATE	DWN	APVD
		L		REVISED PER 0638-0540-04	02AUG04	KW	DC
		L		REVISED PER ECO-06-008661	19JUL06	KW	DC

- △ MATERIAL: NYLON UL94V-2 (NATURAL).
- 2. RECOMMENDED PANEL THICKNESS 2.29 [.090] MAX.
- 3. MARKING FOR UL AND CSA LOGO SHALL BE LOCATED ON ANY EXTERNAL SURFACE.
- △ AMP LOGO AND CIRCUIT NUMBERS LOCATED IN AREA, EITHER SIDE, SIZE OPTIONAL, FROST BACKGROUND.
- △ WALL THICKNESS TO MEASURE 0.36-0.46 [.014-.018]

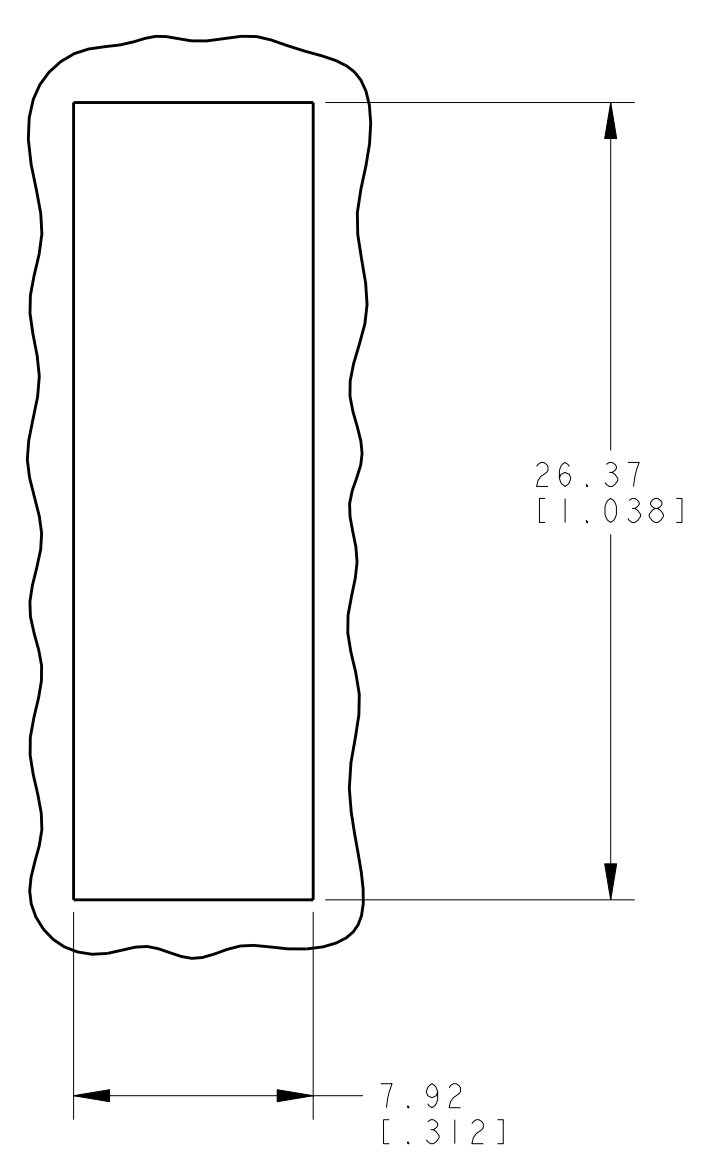
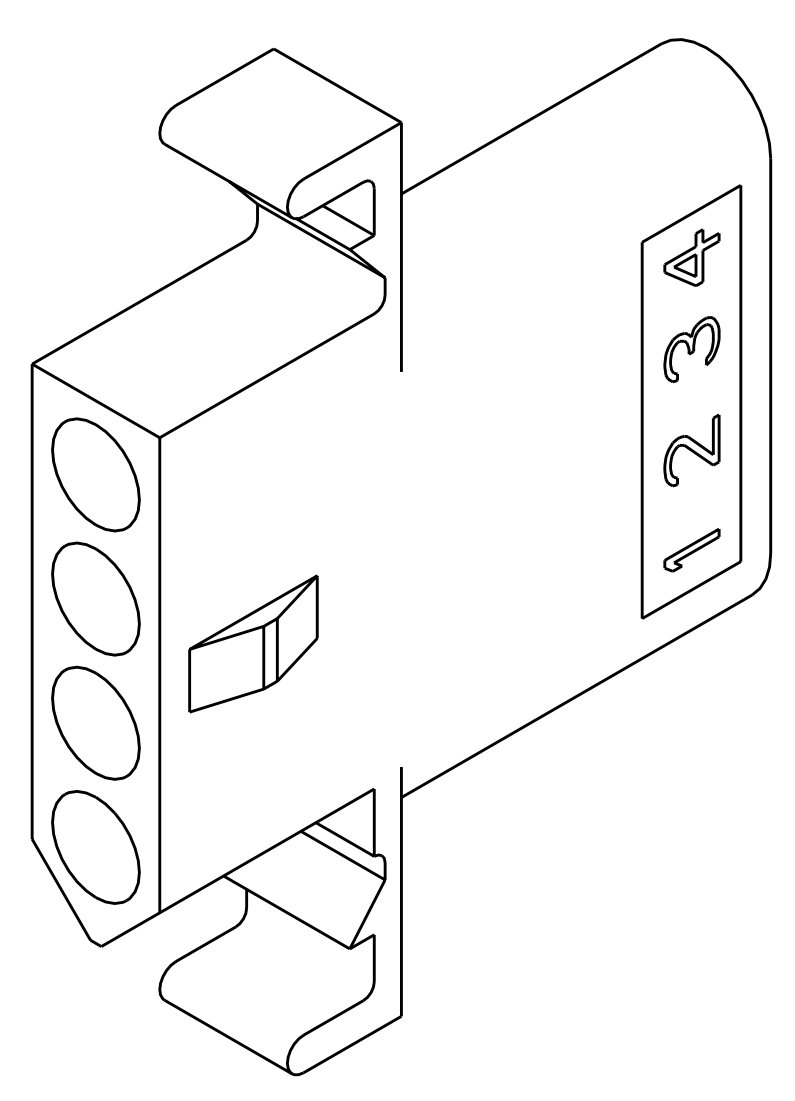
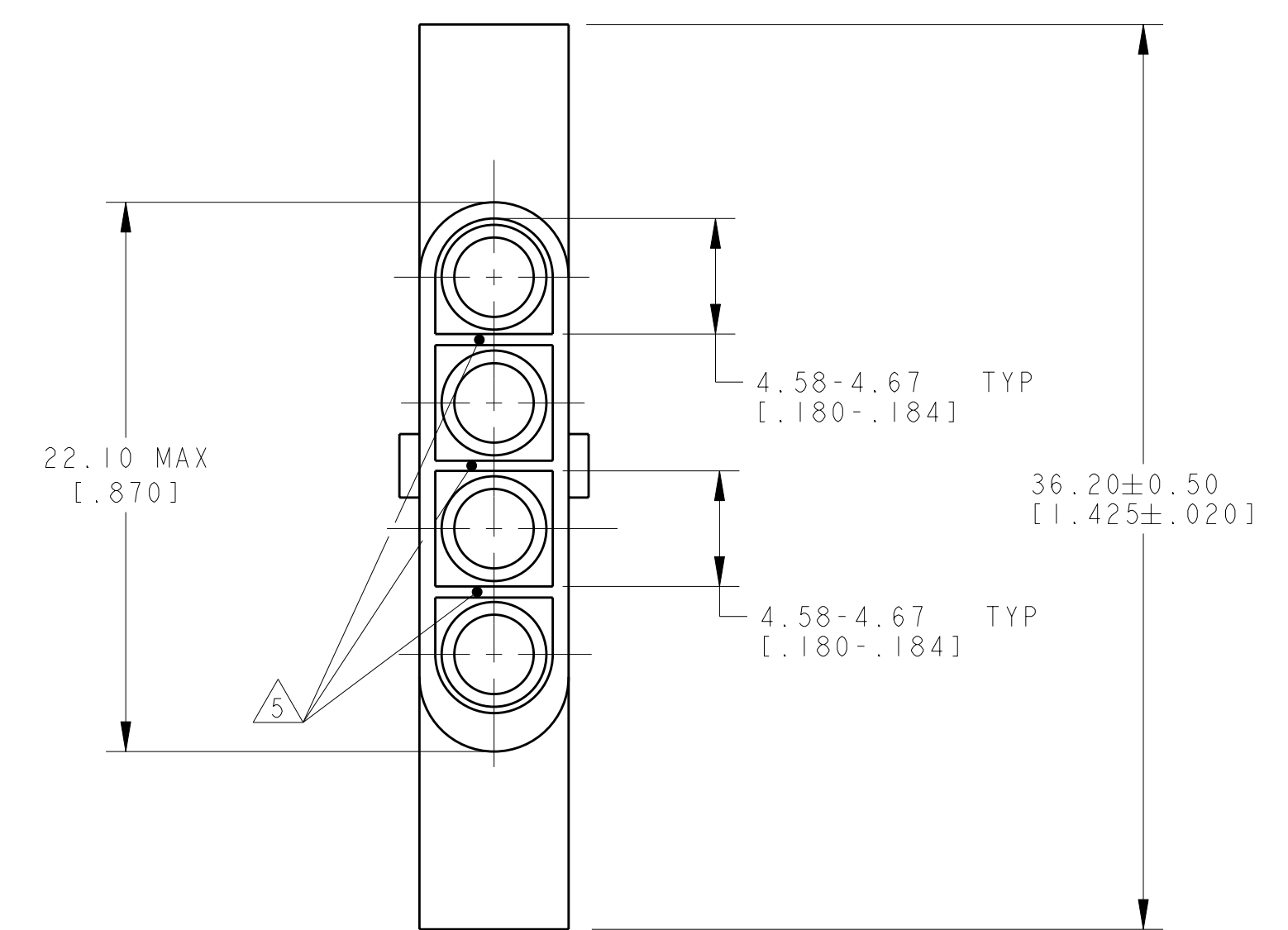
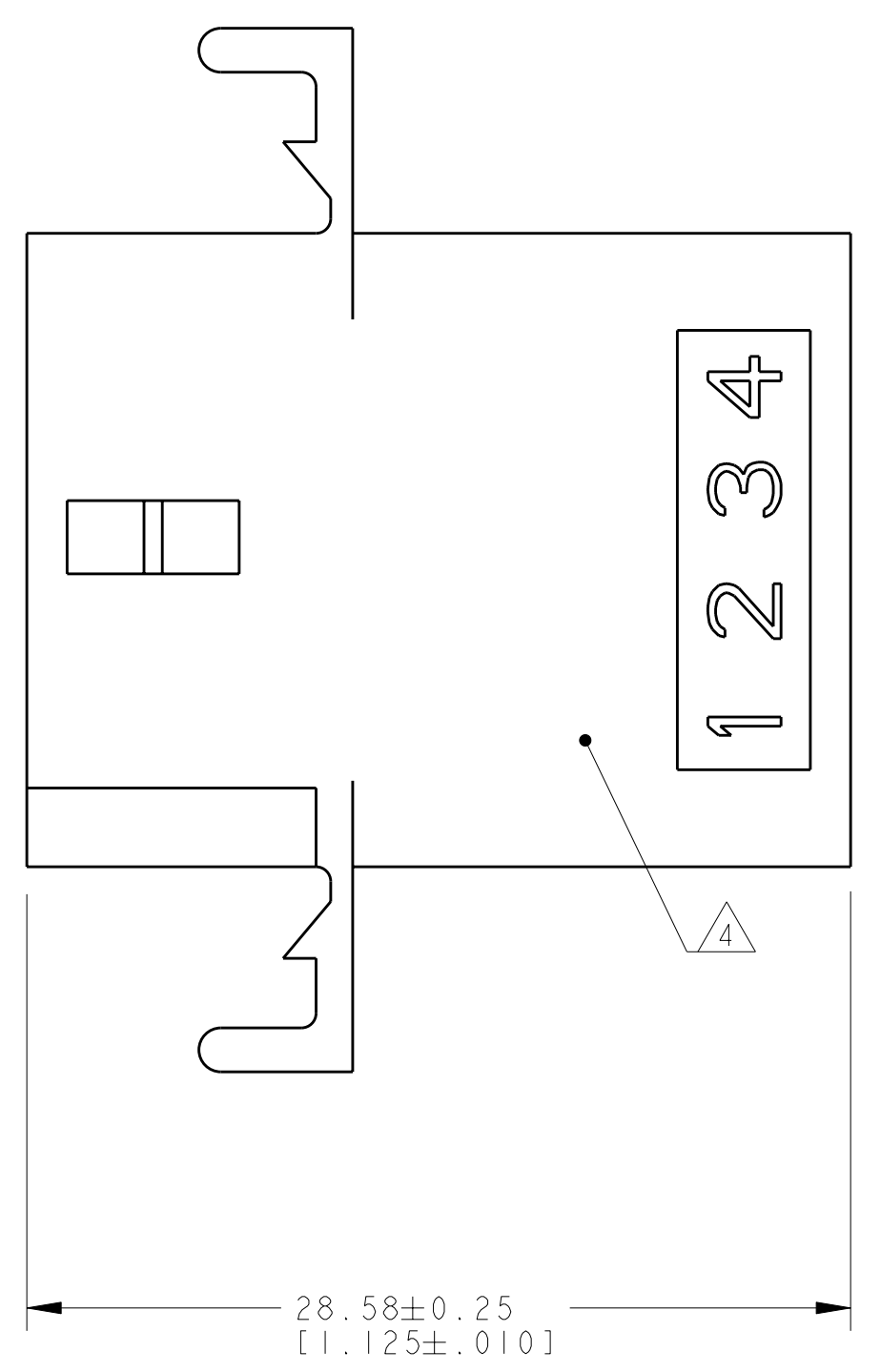
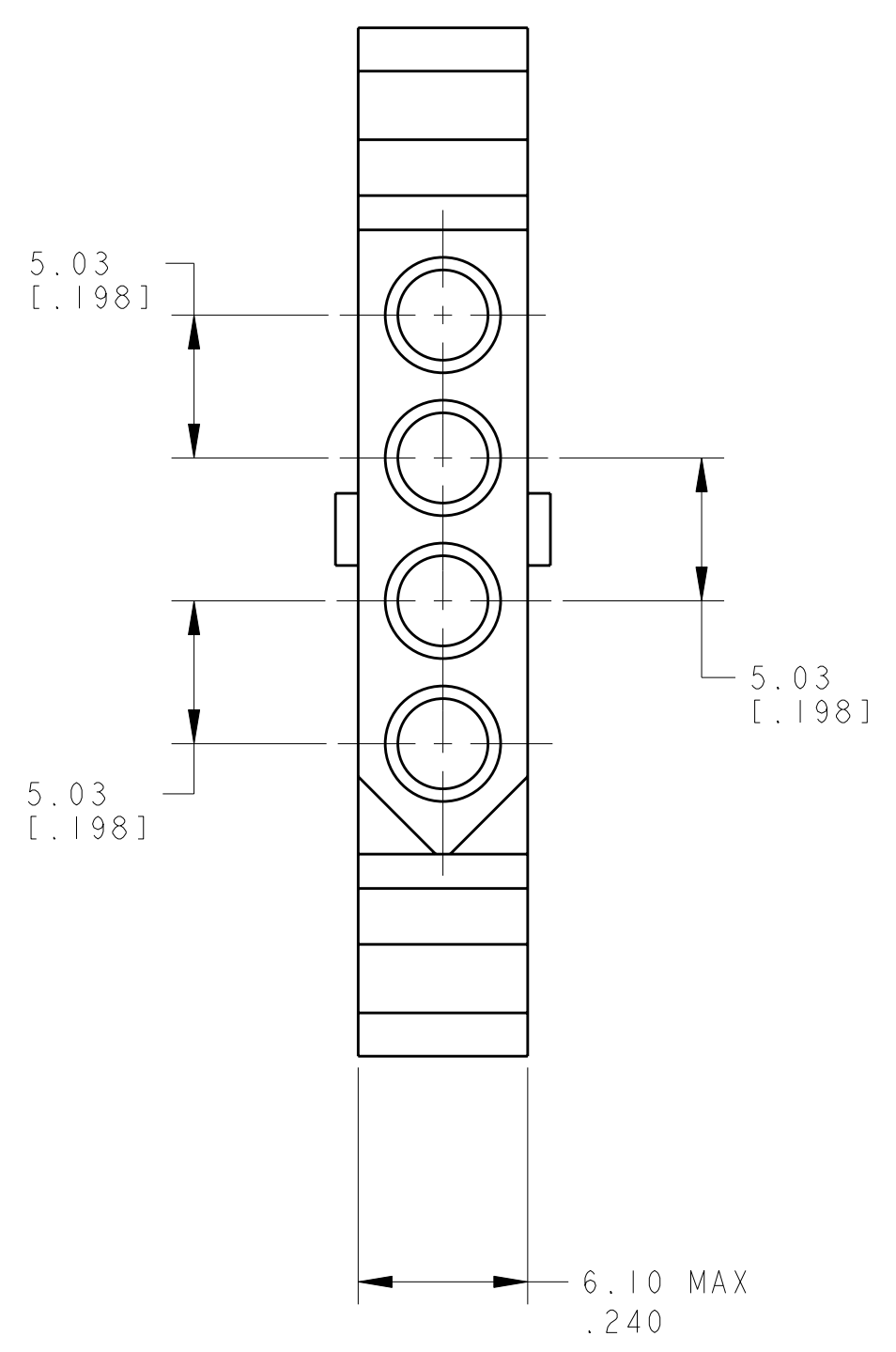

RECOMMENDED PANEL CUT OUT

METRIC

770076-1
PART NUMBER

<small>THIS DRAWING IS UNPUBLISHED. RELEASED FOR PUBLICATION BY TYCO ELECTRONICS CORPORATION. IT IS SUBJECT TO CHANGE WITHOUT NOTICE AND WITHOUT OBLIGATION. SHOULD BE CONTACTED FOR THE LATEST REVISION.</small>		DWN: R. WHITAKER CHK: D. COLEY APVD: D. COLEY	02AUG2004 02AUG2004 02AUG2004	tyco Electronics Tyco Electronics Harrisburg, PA 17105-3608
DIMENSIONS: mm [INCHES]		TOLERANCES UNLESS OTHERWISE SPECIFIED: 9 PLC ± 8 PLC ±0.13 [1.005] 5 PLC ± 4 PLC ± ANGLES ±40° 30'		NAME: RECEPTACLE, 4-CIRCUIT, .093 COMMERCIAL PIN AND SOCKET PRODUCT SPEC: APPLICATION SPEC: SIZE: A CAGE CODE: 770076 DRAWING NO: 770076 WEIGHT: - FINISH: - CUSTOMER DRAWING
MATERIAL: - FINISH: -		RESTRICTED TO: - SCALE: 4:1 SHEET: 1 OF 1 REV: L		