

THIS DRAWING IS UNPUBLISHED. RELEASED FOR PUBLICATION ,19 .
 © COPYRIGHT 19 BY AMP INCORPORATED. ALL INTERNATIONAL RIGHTS RESERVED.

LOC		DIST		P		F		REVISIONS		DATE	APPD
G	14					ZONE	LTR	DESCRIPTION	4-8-93	APPD	
							E	REV & REDRAWN PER 0720-0040-93		APPD	

METRIC
 DIMENSIONS LISTED IN mm [INCHES]

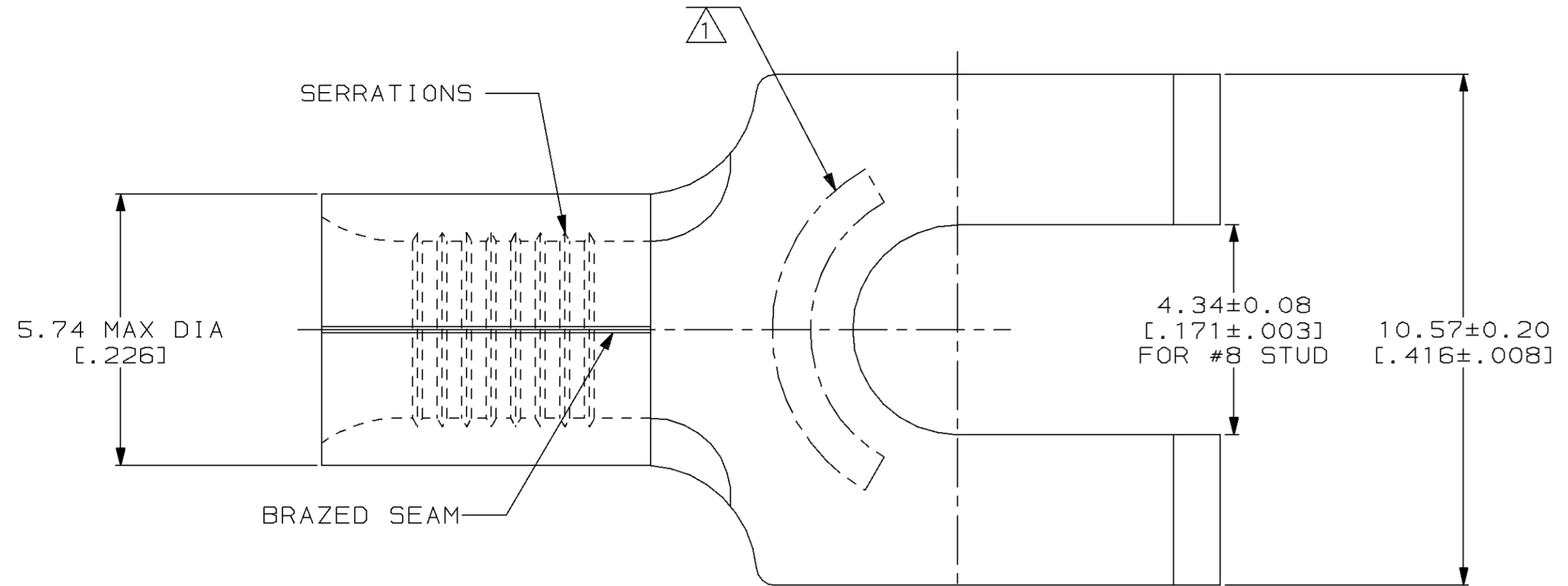

AMP WIRE RANGE	UL E13288 Listed
12-10 AWG SOLID OR STRANDED	12-10 AWG STRANDED
SR LR7189 Certified	MILITARY P/N AND CLASS
12-10 AWG SOLID OR STRANDED	NOT APPLICABLE

1 STAMP AMP 12-10* APPROX AS SHOWN

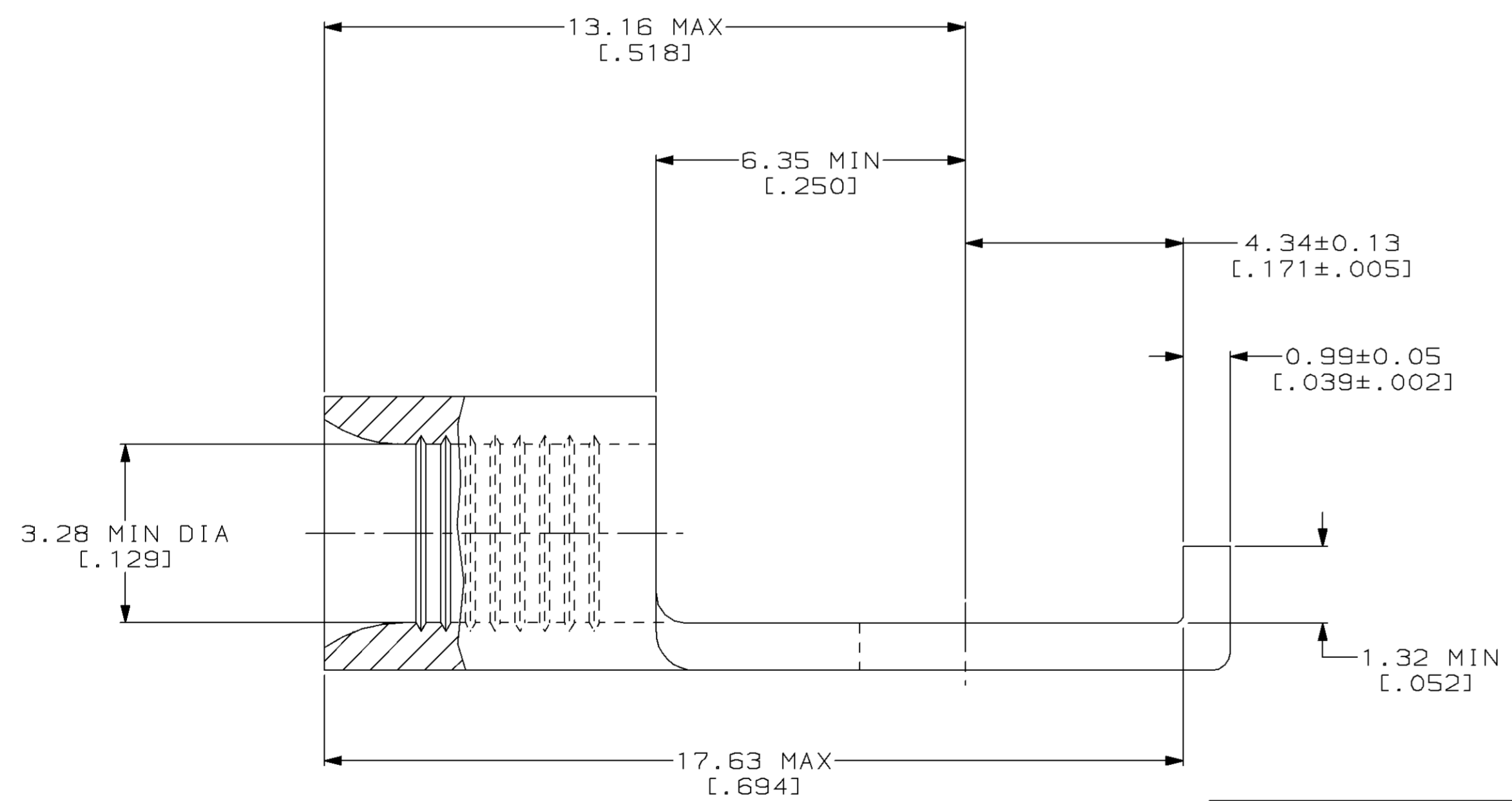

AMP INCORPORATED CUSTOMER SERVICE SYSTEMS		MAX RECOMMENDED OPERATING TEMPERATURE: 170°C MAX		DO NOT SCALE PRINT. UNLESS SPECIFIED DIMENSIONS IN mm [INCHES] TOLERANCES ON: 2 PLC DEC ± - 3 PLC DEC ± - ANGLES ± -		DR 4-8-93 TA BRINKMAN		323143 PART NO	
FOR ADDITIONAL PRODUCT INFORMATION OR COPIES OF DRAWINGS AND TECHNICAL DOCUMENTS		PRODUCT INFORMATION CENTER 1-800-522-6752		VOLTAGE RATING: NOT APPLICABLE		MATERIAL COPPER PER ASTM B-152 ANNEALED		AMP Incorporated Harrisburg, PA 17105-3608	
FOR APPLICATION TOOLING INFORMATION		TOOLING ASSISTANCE CENTER 1-800-722-1111		WIRE CROSS SECTIONAL AREA RANGE: 2.62-6.64mm² [5,180-13,100] CIR MILS SOLID OR STRANDED		FINISH TIN PLATE 0.00254 [0.00100] MIN THK PER MIL-T-10727		NAME TERMINAL, FLANGED SPADE, SOLISTRAND™	
FOR ORDER ENTRY		1-800-526-5142		THIS DRAWING IS A CONTROLLED DOCUMENT FOR AMP INCORPORATED. IT IS SUBJECT TO CHANGE AND THE CONTROLLING ENGINEERING ORGANIZATION SHOULD BE CONTACTED FOR THE LATEST REVISION.		APPLICATION SPEC -		SIZE CAGE CODE DRAWING NO	
						WEIGHT -		SCALE 10:1 00779 C=323143	
								SHEET 1 OF 1	