

THIS DRAWING CONTAINS INFORMATION PROPRIETARY TO RF INDUSTRIES,  
 ANY UNAUTHORIZED USE OF THIS DRAWING IS EXPRESSLY PROHIBITED  
 WITHOUT WRITTEN PERMISSION FROM RF INDUSTRIES.  
 ANY VIOLATION IS PUNISHABLE UNDER U.S. COPYRIGHT LAWS.

PART NO.		<b>RFF-1402-D</b>		
REV	DESCRIPTION	DWN	DATE	APPROVED
-	ENGINEERING RELEASE	CZS	2/10/03	JDMc
A	MODIFIED STRIP DIMENSIONS	JDM	7/26/12	JDMc

ALL DIMENSIONS ARE REFERENCE ONLY

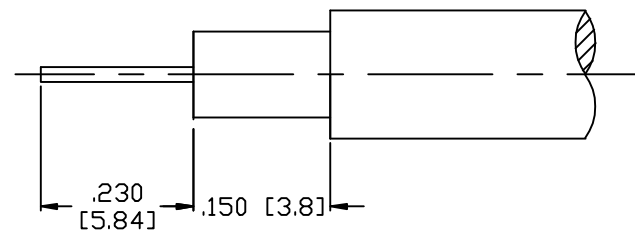
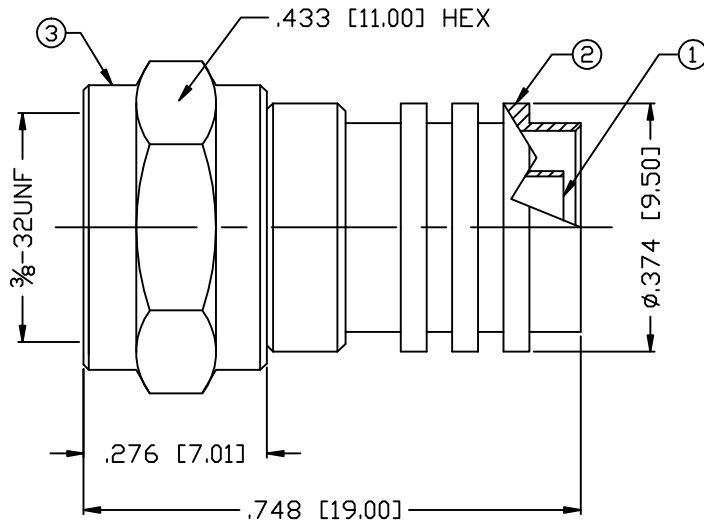

INSERT CABLE INTO THE REAR OF THE CONNECTOR  
 AND CRIMP

RECOMMENDED STRIPPING DIMENSIONS  
RECOMMENDED CRIMP DIE: .324

SPECIFICATIONS:

IMPEDANCE: 75 Ohms  
 FREQUENCY RANGE: 0-1 GHz  
 WORKING VOLTAGE: 500 V rms @ sea level  
 TEMPERATURE RANGE: -65°C TO 165°C  
 INSULATION RESISTANCE: 5k M Ohms min.  
 FOR RG-59, 59A, 59B, 62, 62A, 62C/U; ALPHA 9059, 9062,  
 9830, 9840, 9845; BELDEN 8221, 8241, 9169, 9204,  
 9228; CANARE LV-61S; CommScope 5555, 5560, 5563

1	BODY	1	BRASS	NICKEL	000367	
2	FERRULE	1	BRASS	NICKEL		
3	SHELL	1	BRASS	NICKEL		
4						
5						
6						
7						
8						
9						
10					DRAWN	
11					C. ZUNIGA	
12					2/10/03	
13					CHECKED	
14						
					ORJ DRAWN	
					C. ZUNIGA	
					2/10/03	
#	DESCRIPTION	QTY	MATRL	FINISH	APPROVALS	DATE

- UNLESS OTHERWISE SPECIFIED:
1. REMOVE ALL BURRS
  2. BREAK ALL CORNERS & EDGES .005 R. MAX.
  3. CHAMFER 1ST & LAST THREADS 45°
  4. SURFACE ROUGHNESS 63 FINISH MIL-STD-10
  5. DIAMETERS ON COMMON CENTERS TO BE CONCENTRIC WITHIN .002 T.I.R.
  6. ALL DIMENSIONS ARE AFTER PLATING.

DIMENSIONS ARE IN MILLIMETERS  
 UNLESS OTHERWISE NOTED  
 TOLERANCES ARE:  
 DECIMALS                      DIAMETER  
 .xxx±.003 [.08]                .xxx±.001 [.03]  
 .xx±.005 [.13]                 .xx±.003 [.08]

**RF connectors**  
 DIVISION OF RF INDUSTRIES, LTD.

7610 MIRAMAR RD  
 SAN DIEGO, CA 92126  
 (858) 549-6340  
 (858) 549-6345 FAX

**F PLUG CRIMP**

SIZE	CABLE GROUP	DWG NO.	REV
A	D	RFF-1402-D	A
SCALE: NTS		CAD FILE OUTLINE	SHEET 1 OF 1