

## Features

- Reference Oscillator up to 15 MHz (Tuned)
- Oscillator Buffer Output (for AM Up/Down Conversion)
- Two Programmable 16-bit Dividers
- Fine-tuning Steps Possible
- Fast Response Time Due to Integrated Loop Push-pull Stage
- 3-wire Bus (Enable, Clock and Data; 3V and 5V Microcontrollers Acceptable)
- Four Programmable Switching Outputs (Open Drain)
- Three DACs for Software Controlled Tuner Alignment
- Low-power Consumption
- High Signal to Noise Ratio (SNR)
- Integrated Band Gap – Only One Supply Voltage Necessary

## 1. Description

The ATR4256 is a synthesizer IC for FM receivers and an AM up-conversion system in BiCMOS technology. Together with the AM/FM IC ATR4258 or ATR4255, it comprises a complete AM/FM car radio front-end, which is also recommended for RDS (Radio Data System) applications. It is controlled by a 3-wire bus and also contains switches and Digital to Analog Converters (DACs) for software-controlled alignment of the AM/FM tuner. The ATR4256 is the pin-compatible successor IC of U4256BM-R.

Figure 1-1. Block Diagram

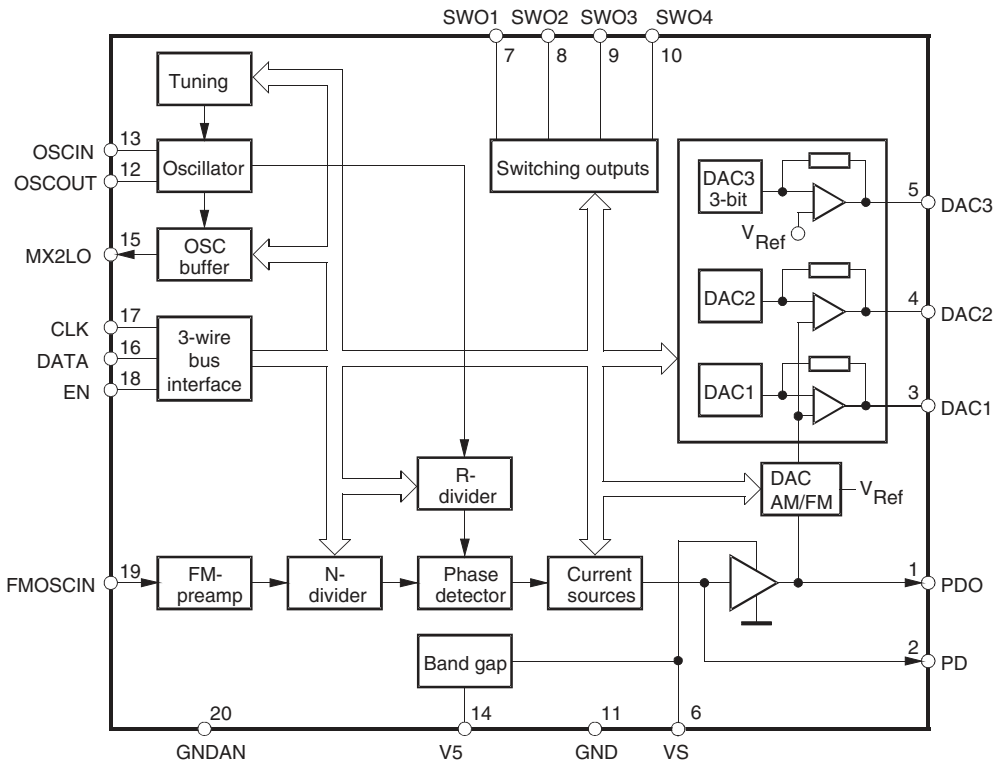

## Frequency Synthesizer for Radio Tuning

## ATR4256

## 2. Pin Configuration

Figure 2-1. Pinning SSO20

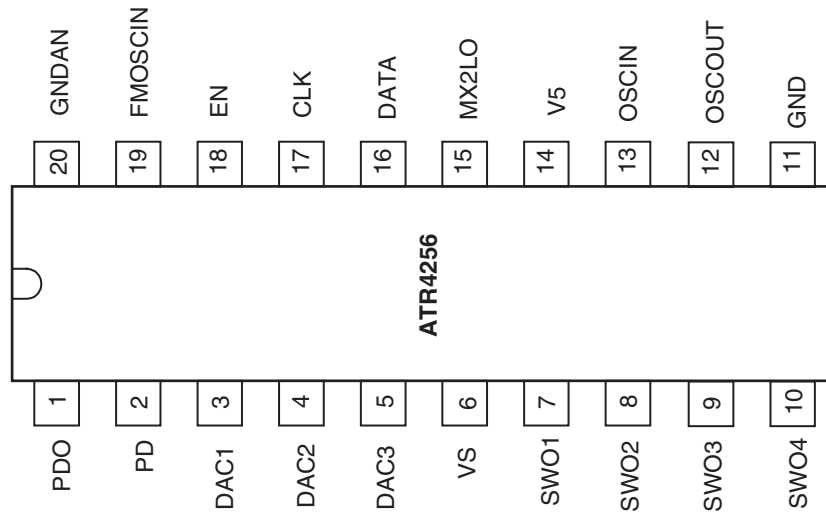

Table 2-1. Pin Description

Pin	Symbol	Function
1	PDO	Phase detector output
2	PD	Pulsed current output
3	DAC1	Digital-to-analog converter 1
4	DAC2	Digital-to-analog converter 2
5	DAC3	Digital-to-analog converter 3
6	VS	Supply voltage, analog part
7	SWO1	Switching output 1
8	SWO2	Switching output 2
9	SWO3	Switching output 3
10	SWO4	Switching output 4
11	GND	Ground, digital part
12	OSCOUT	Reference oscillator output
13	OSCIN	Reference oscillator input
14	V5	Capacitor band gap
15	MX2LO	Oscillator buffer output
16	DATA	Data input
17	CLK	Clock
18	EN	Enable
19	FMOSCIN	FM-oscillator input
20	GNDAN	Ground, analog part

### 3. Functional Description

For a tuned FM-broadcast receiver, the following parts are needed:

- Voltage-controlled Oscillator (VCO)
- Antenna Amplifier Tuned Circuit
- RF Amplifier Tuned Circuit

Typical modern receivers with electronic tuning are tuned to the desired FM frequency by the frequency synthesizer IC ATR4256. The special design allows the user to build software-controlled tuner alignment systems. Two programmable DACs (Digital-to-Analog Converter) support the computer-controlled alignment. The output of the PLL is a tuning voltage which is connected to the VCO of the receiver IC. The output of the VCO is equal to the desired station frequency plus the IF (10.7 MHz). The RF and the oscillator signal (VCO) are both input to the mixer that translates the desired FM-channel signal to the fixed IF signal. For FM, the double-conversion system of the receiver requires exactly 10.7 MHz for the first IF frequency, which determines the center frequency of the software-controlled integrated second IF filter.

If this oscillator tuning feature is not used, the internal capacitors have to be switched off and the oscillator has to be operated with high-quality external capacitors to ensure that the operational frequency is exactly 10.250 MHz.

When dimensioning the oscillator circuit, it is important that the additional capacitors enable the oscillator to operate through its complete tracking range. The oscillating ability depends very strongly on the used crystal oscillator. Initializing the oscillator should be established without switching any additional capacitors to guarantee that the oscillator starts to operate properly. Due to the lower quality of the integrated capacitors compared to discrete capacitors, the amount of the switched integrated capacitors should always be minimized. (If necessary reduce tracking range or use a different crystal oscillator.)

The ATR4256 has a very fast response time of maximum 800  $\mu$ s (at 2 mA,  $f_{\text{Step}} = 50$  kHz, measured on the MPX signal). It has a high signal to noise ratio. Only one supply voltage is necessary, due to an integrated band gap.

## 4. Input/Output Interface Circuits

### 4.1 PDO (Pin 1)

PDO is the buffer amplifier output of the PLL. The bipolar output stage is a rail-to-rail amplifier.

### 4.2 PD (Pin 2)

PD is the current charge pump output of the PLL. The current can be controlled by setting the appropriate bits. The loop filter has to be designed corresponding to the chosen pump current and the internal reference frequency. A recommendation can be found in the application circuit. The charge-pump current can be chosen by setting Bit 71 and Bit 70 as follows:

**Table 4-1.** Current Charge-pump Output

IPD ( $\mu\text{A}$ )	B71	B70
25	0	0
100	0	1
500	1	0
2000	1	1

**Figure 4-1.** Internal Components at PDO Connection

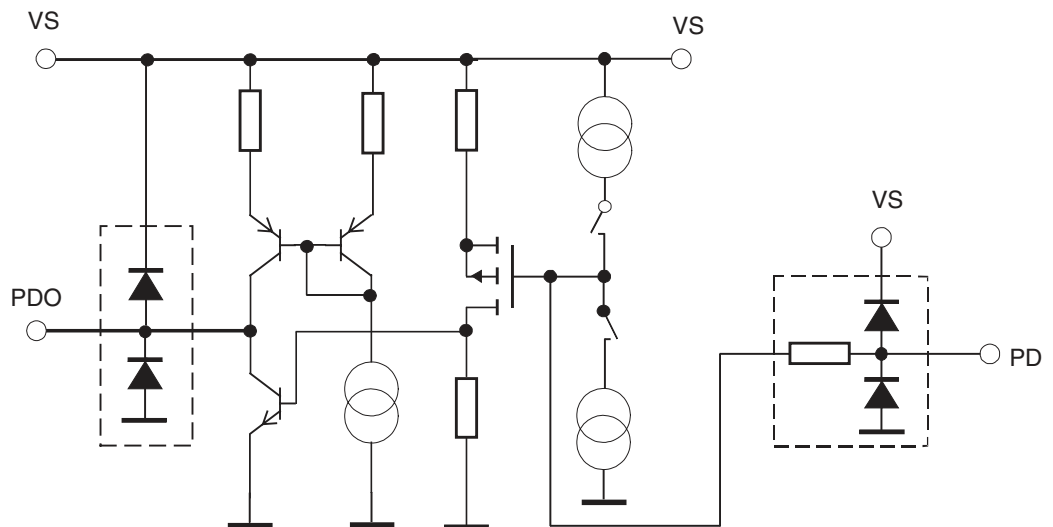

### 4.3 FMOSCIN (Pin 19)

FMOSCIN is the preamplifier input for the FM oscillator signal.

Figure 4-2. Internal Components at FMOSCIN

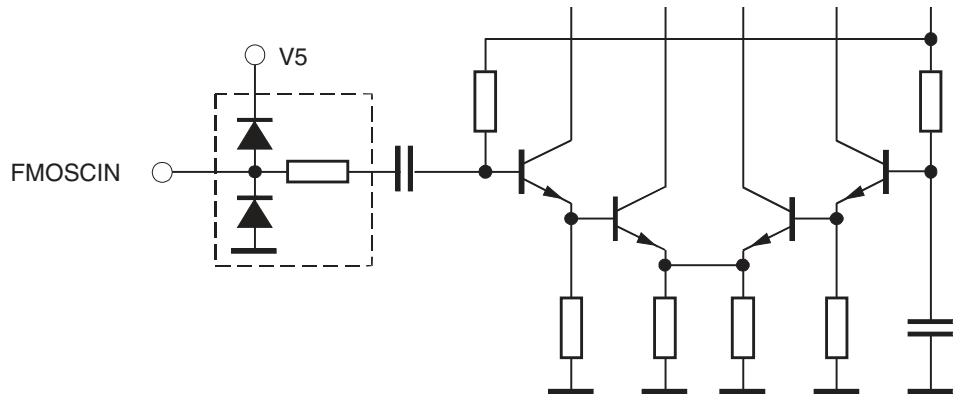

### 4.4 MX2LO (Pin 15)

MX2LO is the buffered output of the crystal oscillator. This signal can be used as a reference frequency for ATR4255 or ATR4258. The oscillator buffer output can be switched by the OSCB bit (B69) as follows.

Table 4-2. MX2LO Settings

MX2LO AC Voltage	B69
ON	0
OFF	1

Figure 4-3. Internal Components at MX2LO

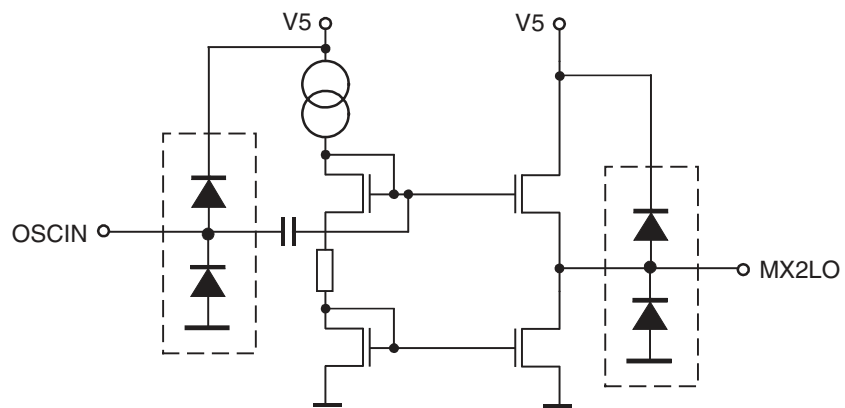

## 4.5 Function of DAC1, DAC2 in FM and AM Mode (Pin 3 and Pin 4)

For automatic tuner alignment, the DAC1 and DAC2 of the ATR4256 can be controlled by setting the gain of VPDO and offset values. Figure 4-4 shows the principle of the operation. In FM Mode the gain is in the range of  $0.69 \times V_{(PDO)}$  to  $2.16 \times V_{(PDO)}$ . The offset range is  $+0.56V$  to  $-0.59V$ . For alignment, DAC1 and DAC2 are connected to the varicaps of the preselection filters. For alignment, offset and gain are set to have the best tuner tracking.

**Figure 4-4.** Principal Operation for Alignment

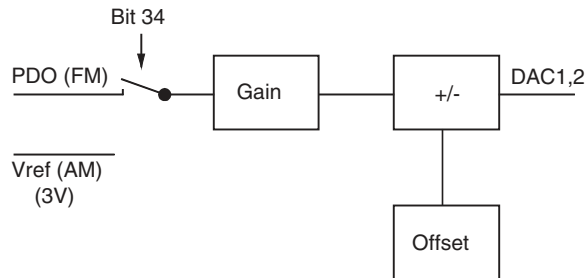

The DAC mode can be controlled by setting Bit 34 as follows

**Table 4-3.** DAC Mode

DAC Mode	B34
FM	0
AM	1

If Bit 34 = 1 (AM Mode), then DAC1 and DAC2 can be used as standard DAC converters. The internal voltage of 3V is connected to the gain and offset input of DAC1 and DAC2 (only in AM Mode). The gain is in the range of  $0.46 \times 3V$  to  $3.03 \times 3V$ . The offset range is  $+1.46V$  to  $-1.49V$ .

**Figure 4-5.** Internal Components at DAC1 and DAC2 Output

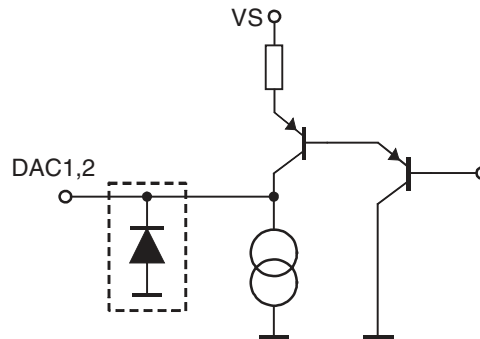

## 4.6 DAC1, DAC2 in FM Mode (Pin 3 and Pin 4)

The gains of DAC1 and DAC2 have a range of  $0.69 \times V_{(PDO)}$  to  $2.16 \times V_{(PDO)}$ .  $V_{(PDO)}$  is the PLL tuning voltage output. This range is divided into 256 steps; one step is approximately  $(2.16 - 0.46) \times V_{(PDO)} / 255 = 0.005764 \times V_{(PDO)}$ . The gain of DAC1 can be controlled by B36 to B43 (bits 0 to 7 of DAC1 Gain), and the gain of DAC2 by B0 to B7 (bits 0 to 7 of DAC2 Gain) as follows:

**Table 4-4.** DAC Gain Setting, FM Mode

Gain DAC1, Approximately	B43	B42	B41	B40	B39	B38	B37	B36	Decimal Gain
Gain DAC2, Approximately	B7	B6	B5	B4	B3	B2	B1	B0	Decimal Gain
$0.69 \times V_{(PDO)}$	0	0	0	0	0	0	0	0	0
$0.69576 \times V_{(PDO)}$	0	0	0	0	0	0	0	1	1
$0.70153 \times V_{(PDO)}$	0	0	0	0	0	0	1	0	2
$0.70729 \times V_{(PDO)}$	0	0	0	0	0	0	1	1	3
...	...	...	...	...	...	...	...	...	...
$0.99549 \times V_{(PDO)}$	0	0	1	1	0	1	0	1	53
...	...	...	...	...	...	...	...	...	...
$2.14847 \times V_{(PDO)}$	1	1	1	1	1	1	0	1	253
$2.15424 \times V_{(PDO)}$	1	1	1	1	1	1	1	0	254
$2.16 \times V_{(PDO)}$	1	1	1	1	1	1	1	1	255

Offset = 31 (intermediate position)

The offset of DAC1 and DAC2 has a range of 0.56V to -0.59V. This range is divided into 64 steps; one step is approximately  $1.15V / 63 = 18.25 \text{ mV}$ . The offset of DAC1 can be controlled by B44 to B49 (bits 0 to 5 of DAC1 Offset), and the offset of DAC2 by B8 to B13 (bits 0 to 5 of DAC2 Offset) as follows:

**Table 4-5.** DAC Offset Setting, FM Mode

Offset DAC1, Approximately	B49	B48	B47	B46	B45	B44	Decimal Gain
Offset DAC2, Approximately	B13	B12	B11	B10	B9	B8	Decimal Gain
0.56V	0	0	0	0	0	0	0
0.5417V	0	0	0	0	0	1	1
0.5235V	0	0	0	0	1	0	2
0.5052V	0	0	0	0	1	1	3
...	...	...	...	...	...	...	...
+0.0059V	0	1	1	1	1	1	31
...	...	...	...	...	...	...	...
0.5535V	1	1	1	1	0	1	61
-0.5717V	1	1	1	1	1	0	62
-0.59V	1	1	1	1	1	1	63

Gain = 53 (intermediate position)

## 4.7 DAC1, DAC2 in AM Mode (Pin 3 and Pin 4)

In AM mode the DAC input voltage  $V_{(PDO)}$  is internally connected to 3V. The gains of DAC1 and DAC2 have a range of  $0.46 \times 3V$  to  $3.03 \times 3V$ .  $V_{(PDO)}$  is the PLL tuning voltage output. This range is divided into 256 steps; one step is approximately  $(3.03 - 0.46) \times 3V / 255 = 0.01007 \times 3V$ . The gain of DAC1 can be controlled by B36 to B43 (bits 0 to 7 of DAC1 Gain) and the gain of DAC2 by B0 to B7 (bits 0 to 7 of DAC2 gain) as follows:

**Table 4-6. DAC Gain, AM Mode**

Gain DAC1, Approximately	B43	B42	B41	B40	B39	B38	B37	B36	Decimal Gain
Gain DAC2, Approximately	B7	B6	B5	B4	B3	B2	B1	B0	Decimal Gain
$0.4607 \times 3V$	0	0	0	0	0	0	0	0	0
$0.4710 \times 3V$	0	0	0	0	0	0	0	1	1
$0.4812 \times 3V$	0	0	0	0	0	0	1	0	2
$0.4915 \times 3V$	0	0	0	0	0	0	1	1	3
...	...	...	...	...	...	...	...	...	...
$1.0029 \times 3V$	0	0	1	1	0	1	0	1	53
...	...	...	...	...	...	...	...	...	...
$3.0097 \times 3V$	1	1	1	1	1	1	0	1	253
$3.0196 \times 3V$	1	1	1	1	1	1	1	0	254
$3.0296 \times 3V$	1	1	1	1	1	1	1	1	255

Offset = 31 (intermediate position)

Remark:  $V_{(PDO)}$  is 3V in AM mode.

The offset of DAC1 and DAC2 has a range of +1.46V to -1.49V. This range is divided into 64 steps; one step is approximately  $2.95 V / 63 = 46.8 mV$ . The offset DAC1 can be controlled by B44 to B49 (bits 0 to 5 of DAC1 Offset) and the offset of DAC2 by B8 to B13 (bits 0 to 5 of DAC2 Offset) as follows:

**Table 4-7. DAC Offset, AM Mode**

Offset DAC1 Approximately	B49	B48	B47	B46	B45	B44	Decimal Gain
Offset DAC2 Approximately	B13	B12	B11	B10	B9	B8	Decimal Gain
1.4606V	0	0	0	0	0	0	0
1.4138V	0	0	0	0	0	1	1
1.3665V	0	0	0	0	1	0	2
1.3196V	0	0	0	0	1	1	3
...	...	...	...	...	...	...	...
-0.0079V	0	1	1	1	1	1	31
...	...	...	...	...	...	...	...
-1.3975V	1	1	1	1	0	1	61
-1.4447V	1	1	1	1	1	0	62
-1.4917V	1	1	1	1	1	1	63

Gain = 53 (intermediate position)



### 4.8 DAC3 (Pin 5)

The DAC3 output voltage can be controlled by B66 to B68 (bits 0 to 2 of DAC3) as follows:

**Table 4-8.** DAC3 Offset Setting

DAC3 Offset, Approximately	B68	B67	B66
0.55V	0	0	0
1.25V	0	0	1
1.90V	0	1	0
2.60V	0	1	1
3.30V	1	0	0
4.10V	1	0	1
4.80V	1	1	0
5.45V	1	1	1

**Figure 4-6.** Internal Components at DAC3

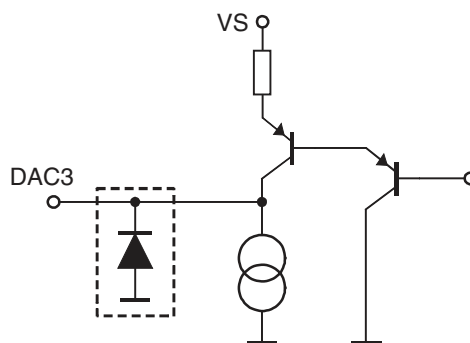

### 4.9 EN, DATA, CLK (Pins 16 to 18)

All functions can be controlled via a 3-wire bus consisting of ENABLE, DATA and CLOCK. The bus is designed for microcontrollers which operate with 3V supply voltage. Details of the data transfer protocol are shown in “3-wire Bus Description” on page 12.

**Figure 4-7.** Internal Components at EN, DATA, CLK

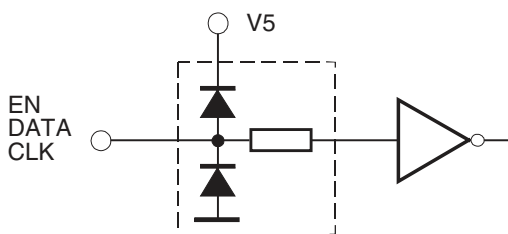

#### 4.10 SWO1, SWO2, SWO3 and SWO4 (Pins 7 to 10)

All switching outputs are “open drain” and can be set and reset by software control. Details are described in the data transfer protocol.

The switching output SWO1 to SWO4 can be controlled as follows (B30 to B33):

**Table 4-9.** SWO1 to SWO4 Setting

Switch Output	B30 + X
SWOx = ON (switch to GND)	0
SWOx = OFF	1

X = 0 to 3

**Figure 4-8.** Internal Components at SWO1, SWO2, SWO3 and SWO4

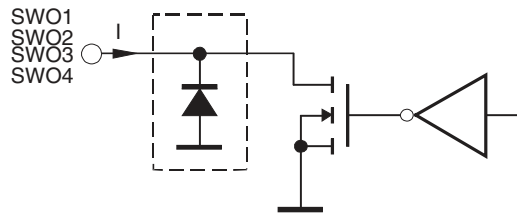

#### 4.11 OSCIN, OSCOUT (Pin 12 and Pin 13)

A crystal resonator (up to 15 MHz) is connected between OSCIN and OSCOUT in order to generate the reference frequency. By using the ATR4256 in connection with ATR4255 or ATR4258, the crystal frequency must be 10.25 MHz. The complete application circuit is shown in [Figure 6-2](#). If a reference is available, it can be applied at OSCIN. The minimum voltage should be 100 mVrms. In this case, pin OSCOUT has to be open.

The tuning capacity for the crystal oscillator has a range of 0.5 pF to 71.5 pF. The values are coded binary. The tuning can be controlled by B78 to B85 as follows:

**Table 4-10.** Crystal Tuning Capacitance

B85 = 1 [pF]	B85 = 0 [pF]	B84	B83	B82	B81	B80	B79	B78
0	8.0	1	1	1	1	1	1	1
0.5	8.5	1	1	1	1	1	1	0
1.0	9.0	1	1	1	1	1	0	1
1.5	19.5	1	1	1	1	1	0	0
...	...	...	...	...	...	...	...	...
63.0	71.0	0	0	0	0	0	0	0
63.5	71.5	0	0	0	0	0	0	0

Figure 4-9. Internal Components at OSCIN and OSCOUT

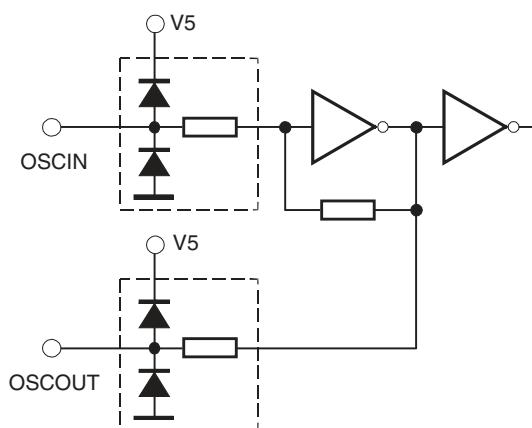
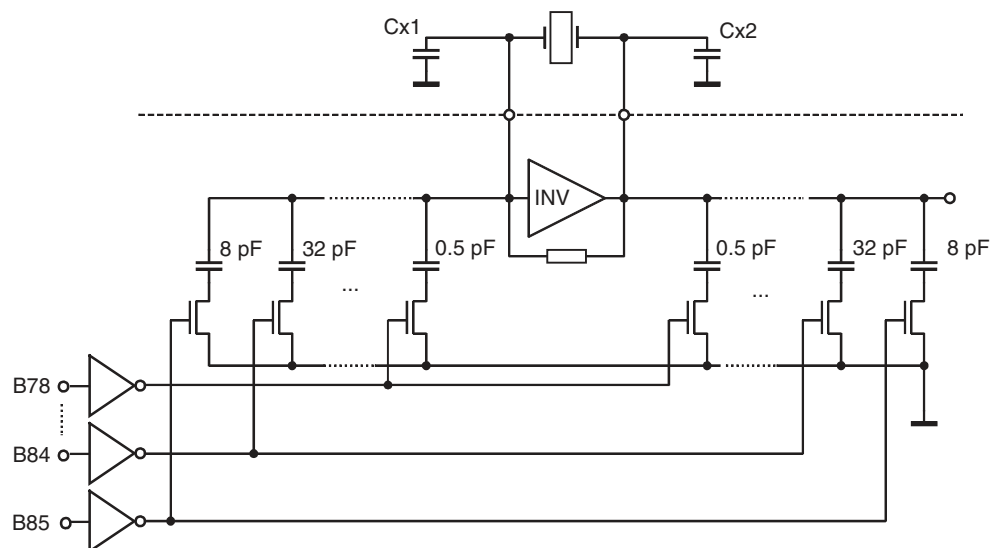
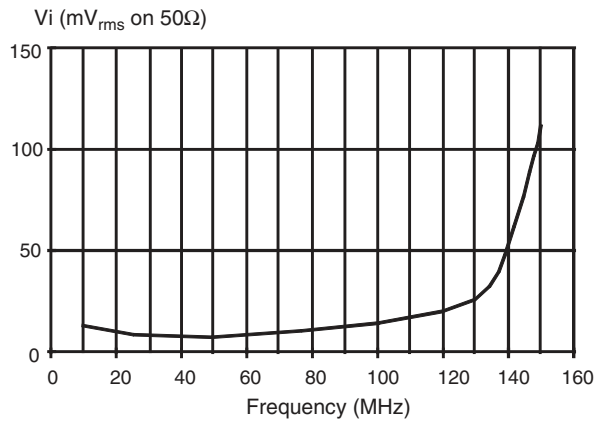

Figure 4-10. Internal Connection of Tuning Capacity for Crystal Oscillator



## 5. Application Information

Figure 5-1. FMOSCIN Sensitivity



## 6. 3-wire Bus Description

The register settings of ATR4256 are programmed by a 3-wire bus protocol. The bus protocol consists of separate commands. A defined number of bits are transmitted sequentially during each command.

One command is used to program all the bits of one register. The different registers available (see “Data Transfer” on page 14) are addressed by the length of the command (number of transmitted bits) and by two address bits, that are unique to each register of a given length. 16-bit registers are programmed by 16-bit commands and 24-bit registers are programmed by 24-bit commands.

Each bus command starts with a rising edge on the enable line (EN) and ends with a falling edge on EN. EN has to be kept HIGH during the bus command.

The sequence of transmitted bits during one command starts with the LSB of the first byte and ends with the MSB of the last byte of the register addressed. To transmit one bit (0 or 1) DATA has to be set to the appropriate value (LOW or HIGH) and a LOW to HIGH transition has to be performed on the clock line (CLK) while DATA is valid. The DATA is evaluated at the rising edges of CLK. The number of LOW to HIGH transitions on CLK during the HIGH period of EN is used to determine the length of the command.

The bus protocol and the register addressing of ATR4256 are compatible to the addressing used in ATR4255 and ATR4258. That means ATR4256 and ATR4255 (or ATR4258) can be operated on the same 3-wire bus as shown in the application circuit.

Figure 6-1. 3-wire Bus Timing Diagram

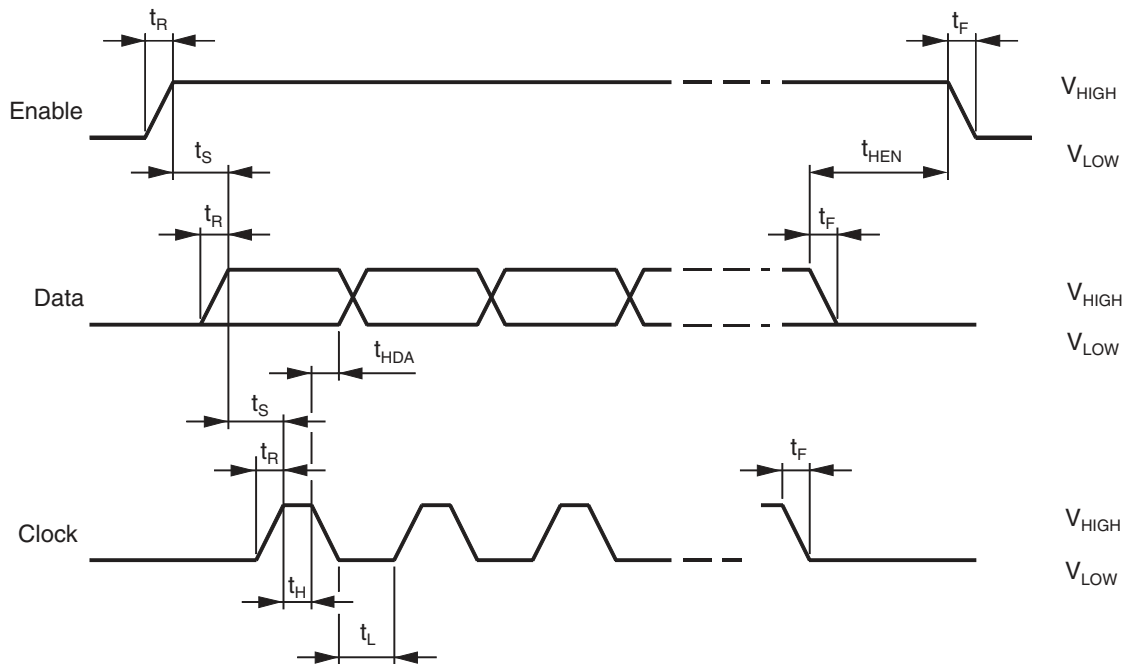
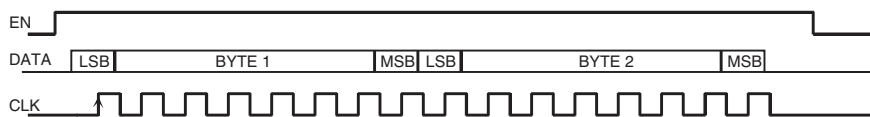
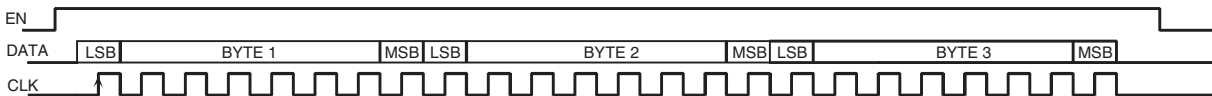

Figure 6-2. 3-wire Pulse Diagram

16-bit command



24-bit command



e.g. R-Divider

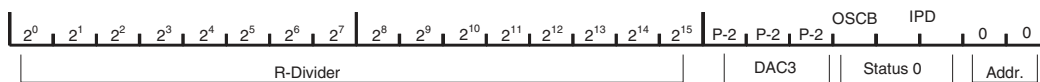

## 6.1 Data Transfer

**Table 6-1.** Control Registers

A																							
MSB		BYTE 3					LSB	MSB		BYTE 2					LSB	MSB		BYTE 1					LSB
ADDR.		STATUS 0			DAC3			R-Divider															
0	0	IPD	OSCB 0=on, 1=off	P-2 <sup>2</sup>	P-2 <sup>1</sup>	P-2 <sup>0</sup>	2 <sup>15</sup>	2 <sup>14</sup>	2 <sup>13</sup>	2 <sup>12</sup>	2 <sup>10</sup>	2 <sup>11</sup>	2 <sup>9</sup>	2 <sup>8</sup>	2 <sup>7</sup>	2 <sup>6</sup>	2 <sup>5</sup>	2 <sup>4</sup>	2 <sup>3</sup>	2 <sup>2</sup>	2 <sup>1</sup>	2 <sup>0</sup>	
		B71	B70	B69	B68	B67	B66	B65	B64	B63	B62	B61	B60	B59	B58	B57	B56	B55	B54	B53	B52	B51	B50

B																							
MSB		BYTE 3					LSB	MSB		BYTE 2					LSB	MSB		BYTE 1					LSB
ADDR.		STATUS 1						N-Divider															
0	1	0	AM=1 FM=0 DAC	SWO4 0=on, 1=off	SWO3 0=on, 1=off	SWO2 0=on, 1=off	SWO1 0=on, 1=off	2 <sup>15</sup>	2 <sup>14</sup>	2 <sup>13</sup>	2 <sup>12</sup>	2 <sup>10</sup>	2 <sup>11</sup>	2 <sup>9</sup>	2 <sup>8</sup>	2 <sup>7</sup>	2 <sup>6</sup>	2 <sup>5</sup>	2 <sup>4</sup>	2 <sup>3</sup>	2 <sup>2</sup>	2 <sup>1</sup>	2 <sup>0</sup>
		B35	B34	B33	B32	B31	B30	B29	B28	B27	B26	B25	B24	B23	B22	B21	B20	B19	B18	B17	B16	B15	B14

C															
MSB		BYTE 2					LSB	MSB		BYTE 1					LSB
ADDR.		DAC1 OFFSET						DAC1 GAIN							
0	0	O-2 <sup>5</sup>	O-2 <sup>4</sup>	O-2 <sup>3</sup>	O-2 <sup>2</sup>	O-2 <sup>1</sup>	O-2 <sup>0</sup>	G-2 <sup>7</sup>	G-2 <sup>6</sup>	G-2 <sup>7</sup>	G-2 <sup>5</sup>	G-2 <sup>4</sup>	G-2 <sup>3</sup>	G-2 <sup>2</sup>	G-2 <sup>0</sup>
		B49	B48	B47	B46	B45	B44	B43	B42	B41	B40	B39	B38	B37	B36

D															
MSB		BYTE 2					LSB	MSB		BYTE 1					LSB
ADDR.		DAC2 OFFSET						DAC2 GAIN							
0	1	O-2 <sup>5</sup>	O-2 <sup>4</sup>	O-2 <sup>3</sup>	O-2 <sup>2</sup>	O-2 <sup>1</sup>	O-2 <sup>0</sup>	G-2 <sup>7</sup>	G-2 <sup>6</sup>	G-2 <sup>7</sup>	G-2 <sup>5</sup>	G-2 <sup>4</sup>	G-2 <sup>3</sup>	G-2 <sup>2</sup>	G-2 <sup>0</sup>
		B13	B12	B11	B10	B9	B8	B7	B6	B5	B4	B3	B2	B1	B0

E															
MSB		BYTE 2					LSB	MSB		BYTE 1					LSB
ADDR.		Oscillator tuning function							Not used						
1	0	8 pF	32 pF	16 pF	8 pF	4 pF	2 pF	1 pF	0.5 pF	X	X	X	X	X	X
		B85	B84	B83	B82	B81	B80	B79	B78	B77	B76	B75	B74	B73	B72

## 7. Absolute Maximum Ratings

Stresses beyond those listed under “Absolute Maximum Ratings” may cause permanent damage to the device. This is a stress rating only and functional operation of the device at these or any other conditions beyond those indicated in the operational sections of this specification is not implied. Exposure to absolute maximum rating conditions for extended periods may affect device reliability.

Parameters	Symbol	Value	Unit
Analog supply voltage, pin 6	$V_S$	8 to 12	V
Input voltage BUS; pins 16, 17 and 18	$V_I$	-0.3 to +5.3	V
Output current switches; pins 7, 8, 9 and 10 (see <a href="#">Figure 4-8 on page 10</a> )	$I_O$	-1 to +5	mA
Drain voltage switches; pins 7, 8, 9 and 10	$V_{OD}$	15	V
Ambient temperature range	$T_{amb}$	-40 to +85	°C
Storage temperature range	$T_{stg}$	-40 to +125	°C
Junction temperature	$T_j$	125	°C
Electrostatic handling M.M.	$V_{ESD}$	300	V

## 8. Thermal Resistance

Parameters	Symbol	Value	Unit
Junction ambient, when soldering to PCB	$R_{thJA}$	140	K/W

## 9. Operating Range

All voltages are referred to GND (Pin 11)

Parameters	Symbol	Min.	Typ.	Max.	Unit
Supply voltage range, pin 6	$V_S$	8	8.5	12	V
Ambient temperature	$T_{amb}$	-40		+85	°C
Input frequency FMOSCIN, pin 19	$f_{in}$	15		160	MHz
Programmable N, R divider	SF	2		65535	
Crystal reference oscillator, pins 12 and 13	fXTAL	0.1		15	MHz

## 10. Electrical Characteristics

Test Conditions (unless otherwise specified):  $V_S = 8.5V$ ,  $T_{amb} = 25^\circ C$ .

No.	Parameters	Test Conditions	Pin	Symbol	Min.	Typ.	Max.	Unit	Type*
<b>1</b>	<b>Supply Voltage</b>								
1.1	Analog supply voltage		6	$V_S$	8	8.5	12	V	A
<b>2</b>	<b>Supply Current</b>								
2.1	Analog supply current		6	$I_S$	5	10	25	mA	A
<b>3</b>	<b>OSCIN</b>								
3.1	Input voltage	$f = 0.1$ to 15 MHz	13	OSC	100			mV <sub>rms</sub>	B
<b>4</b>	<b>OSC Buffer (MX2LO)</b>								
4.1	Output AC voltage	At pin15: 47 pF and 1 k $\Omega$	15	$V_{MX2LO}$	80	120	200	mV <sub>pp</sub>	B
4.2	Output DC voltage		15	$V_{MX2LO}$	1.8	2.0	2.2	V	A
<b>5</b>	<b>FMOSCIN</b>								
5.1	Input voltage	$f = 15$ to 120 MHz $f = 120$ to 160 MHz	19	FMOSC FMOSC	40 150			mV <sub>rms</sub> mV <sub>rms</sub>	B B
<b>6</b>	<b>Pulsed Current Output PD</b>								
6.1	Output current B71 to B70 = "00"	PD = 2.5V	2	$\pm IPD$	20	25	30	$\mu A$	A
6.2	Output current B71 to B70 = "01"	PD = 2.5V	2	$\pm IPD$	80	100	120	$\mu A$	A
6.3	Output current B71 to B70 = "10"	PD = 2.5V	2	$\pm IPD$	400	500	600	$\mu A$	A
6.4	Output current B71 to B70 = "11"	PD = 2.5V	2	$\pm IPD$	1500	2000	2400	$\mu A$	A
6.5	Leakage current	PD = 2.5V	2	$\pm IPDL$			20	nA	A
<b>7</b>	<b>PDO</b>								
7.1	Saturation voltage HIGH		3, 4		8.0		8.5	V	A
7.2	Saturation voltage LOW		3, 4		0		0.4	V	A
<b>8</b>	<b>SWO1, SWO2, SWO3, SWO4 (Open Drain)</b>								
8.1	Output leakage current HIGH	Pin 7, 8, 9, 10 over R against 8.5V	7, 8, 9, 10	$I_{SWOH}$			100	nA	A
8.2	Output voltage LOW	$I = 1$ mA	7, 8, 9, 10	$V_{SWOL}$		100	400	mV	A
<b>9</b>	<b>DAC1, DAC2</b>								
9.1	Output current		3, 4	$I_{DAC1,2}$			1	mA	C
9.2	Output voltage		3, 4	$V_{DAC1,2}$	0.3		$V_S - 0.6$	V	A
9.3	Maximum offset range (FM)	Offset = 0, Gain = 53	3, 4		0.45	0.56	0.65	V	A
9.4	Minimum offset range (FM)	Offset = 63, Gain = 53	3, 4		-0.45	-0.57	-0.65	V	A

\*) Type means: A = 100% tested, B = 100% correlation tested, C = Characterized on samples, D = Design parameter



## 10. Electrical Characteristics (Continued)

Test Conditions (unless otherwise specified):  $V_S = 8.5V$ ,  $T_{amb} = 25^\circ C$ .

No.	Parameters	Test Conditions	Pin	Symbol	Min.	Typ.	Max.	Unit	Type*
9.5	Maximum gain range (FM)	Gain = 255, Offset = 31	3, 4		0.63	0.69	0.75		A
9.6	Minimum gain range (FM)	Gain = 0, Offset = 31	3, 4		2.1	2.16	2.23		A
<b>10</b>	<b>DAC3</b>								
10.1	Output current		5	$I_{DAC3}$			1	mA	C
10.2	Output voltage	B68 to B66 = "000"	5	$V_{DAC3}$	0.4	0.55	0.7	V	A
10.3	Output voltage	B68 to B66 = "001"	5	$V_{DAC3}$	1.1	1.25	1.4	V	A
10.4	Output voltage	B68 to B66 = "010"	5	$V_{DAC3}$	1.8	1.90	2.1	V	A
10.5	Output voltage	B68 to B66 = "011"	5	$V_{DAC3}$	2.4	2.60	2.8	V	A
10.6	Output voltage	B68 to B66 = "100"	5	$V_{DAC3}$	3.2	3.30	3.5	V	A
10.7	Output voltage	B68 to B66 = "101"	5	$V_{DAC3}$	3.8	4.10	4.3	V	A
10.8	Output voltage	B68 to B66 = "110"	5	$V_{DAC3}$	4.5	4.80	5.0	V	A
10.9	Output voltage	B68 to B66 = "111"	5	$V_{DAC3}$	5.2	5.45	5.7	V	A
<b>11</b>	<b>3-wire Bus, ENABLE, DATA, CLOCK</b>								
11.1	Input voltage HIGH LOW		16 to 18	$V_{BUSH}$ $V_{BUSL}$	2.7 -0.3		5.3 +0.8	V V	A
11.2	Clock frequency		17				1.0	MHz	A
11.3	Period of CLK HIGH LOW		17	$t_H$ $t_L$	250 250			ns ns	D
11.4	Rise time EN, DATA, CLK		16 to 18	$t_r$			400	ns	D
11.5	Fall time EN, DATA, CLK		16 to 18	$t_f$			100	ns	D
11.6	Set-up time		16 to 18	$t_s$	100			ns	D
11.7	Hold time EN		18	$t_{HEN}$	250			ns	D
11.8	Hold time DATA		16	$t_{HDA}$	0			ns	D

\*) Type means: A = 100% tested, B = 100% correlation tested, C = Characterized on samples, D = Design parameter

**Figure 10-1. Application Circuit**

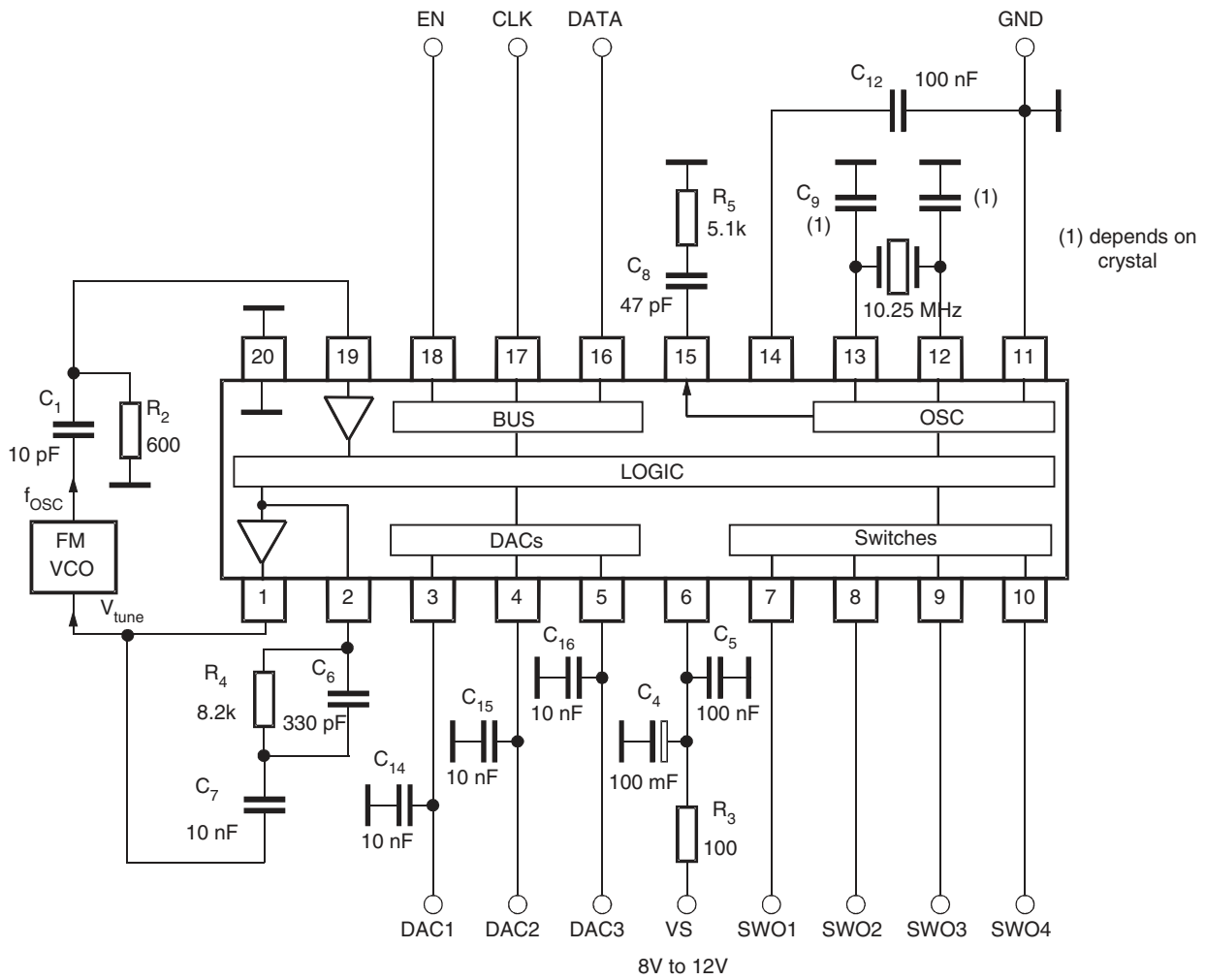



## 11. Ordering Information

Extended Type Number	Package	Remarks
ATR4256-TKSY	SSO20	Tube
ATR4256-TKQY	SSO20	Taped and reeled

## 12. Package Information

### Package SSO20

Dimensions in mm

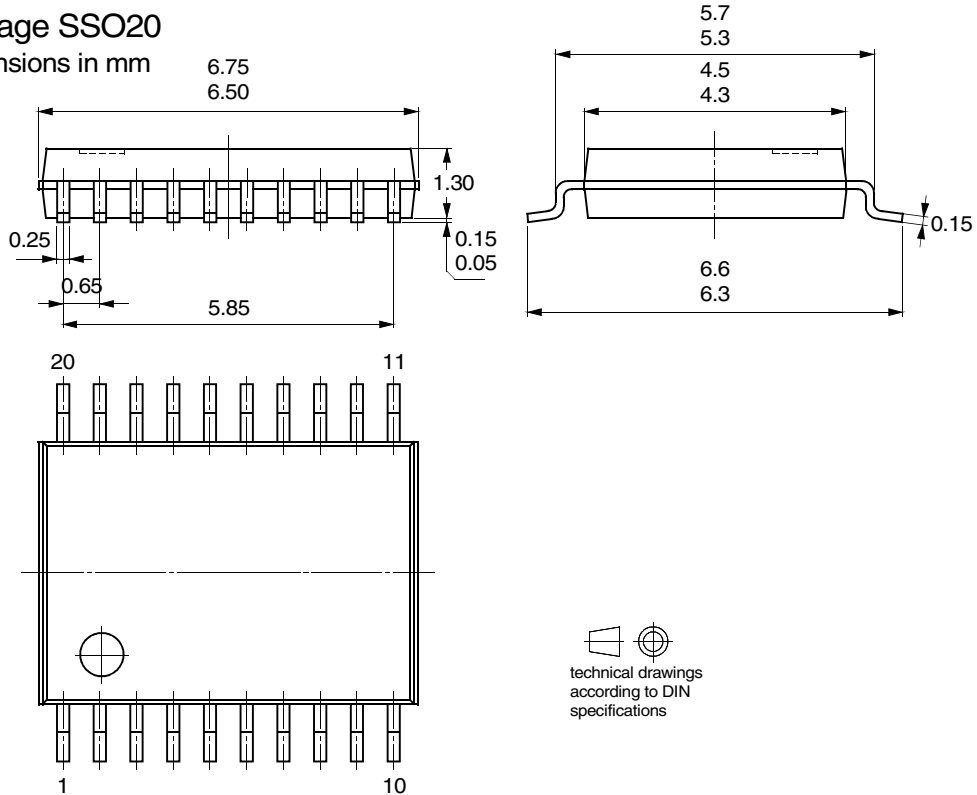

## 13. Revision History

Please note that the following page numbers referred to in this section refer to the specific revision mentioned, not to this document.

Revision No.	History
4867D-AUDR-01/08	<ul style="list-style-type: none"> <li>Section 9 "Operating Range" on page 15 changed</li> </ul>
4867C-AUDR-10/07	<ul style="list-style-type: none"> <li>Put datasheet in the newest template</li> <li>EI. Char. table: row 5.1 changed</li> </ul>
4867B-AUDR-06/06	<ul style="list-style-type: none"> <li>Put data sheet in a new template</li> <li>Pb-free logo on page 1 deleted</li> </ul>



## Headquarters

---

**Atmel Corporation**  
2325 Orchard Parkway  
San Jose, CA 95131  
USA  
Tel: 1(408) 441-0311  
Fax: 1(408) 487-2600

## International

---

**Atmel Asia**  
Room 1219  
Chinachem Golden Plaza  
77 Mody Road Tsimshatsui  
East Kowloon  
Hong Kong  
Tel: (852) 2721-9778  
Fax: (852) 2722-1369

**Atmel Europe**  
Le Krebs  
8, Rue Jean-Pierre Timbaud  
BP 309  
78054  
Saint-Quentin-en-Yvelines Cedex  
France  
Tel: (33) 1-30-60-70-00  
Fax: (33) 1-30-60-71-11

**Atmel Japan**  
9F, Tonetsu Shinkawa Bldg.  
1-24-8 Shinkawa  
Chuo-ku, Tokyo 104-0033  
Japan  
Tel: (81) 3-3523-3551  
Fax: (81) 3-3523-7581

## Product Contact

---

**Web Site**  
[www.atmel.com](http://www.atmel.com)

**Technical Support**  
[broadcast@atmel.com](mailto:broadcast@atmel.com)

**Sales Contact**  
[www.atmel.com/contacts](http://www.atmel.com/contacts)

**Literature Requests**  
[www.atmel.com/literature](http://www.atmel.com/literature)

---

**Disclaimer:** The information in this document is provided in connection with Atmel products. No license, express or implied, by estoppel or otherwise, to any intellectual property right is granted by this document or in connection with the sale of Atmel products. **EXCEPT AS SET FORTH IN ATMEL'S TERMS AND CONDITIONS OF SALE LOCATED ON ATMEL'S WEB SITE, ATMEL ASSUMES NO LIABILITY WHATSOEVER AND DISCLAIMS ANY EXPRESS, IMPLIED OR STATUTORY WARRANTY RELATING TO ITS PRODUCTS INCLUDING, BUT NOT LIMITED TO, THE IMPLIED WARRANTY OF MERCHANTABILITY, FITNESS FOR A PARTICULAR PURPOSE, OR NON-INFRINGEMENT. IN NO EVENT SHALL ATMEL BE LIABLE FOR ANY DIRECT, INDIRECT, CONSEQUENTIAL, PUNITIVE, SPECIAL OR INCIDENTAL DAMAGES (INCLUDING, WITHOUT LIMITATION, DAMAGES FOR LOSS OF PROFITS, BUSINESS INTERRUPTION, OR LOSS OF INFORMATION) ARISING OUT OF THE USE OR INABILITY TO USE THIS DOCUMENT, EVEN IF ATMEL HAS BEEN ADVISED OF THE POSSIBILITY OF SUCH DAMAGES.** Atmel makes no representations or warranties with respect to the accuracy or completeness of the contents of this document and reserves the right to make changes to specifications and product descriptions at any time without notice. Atmel does not make any commitment to update the information contained herein. Unless specifically provided otherwise, Atmel products are not suitable for, and shall not be used in, automotive applications. Atmel's products are not intended, authorized, or warranted for use as components in applications intended to support or sustain life.

© 2008 Atmel Corporation. All rights reserved. Atmel®, logo and combinations thereof, and others are registered trademarks or trademarks of Atmel Corporation or its subsidiaries. Other terms and product names may be trademarks of others.