

**HLMP-3707, HLMP-3807, HLMP-3907, HLMP-3750,  
HLMP-3850, HLMP-3950, HLMP-3960, HLMP-3390,  
HLMP-3490, HLMP-3590, HLMP-1340, HLMP-1440,  
HLMP-1540, HLMP-D640, HLMP-K640**  
T-13/4 (5 mm), T-1 (3 mm), Ultra-Bright LED Lamps



## Data Sheet



### Description

These non-diffused lamps out-perform conventional LED lamps. By utilizing new higher intensity material, we achieve superior product performance.

The HLMP-3750/-3390/-1340 Series Lamps are Gallium Arsenide Phosphide on Gallium Phosphide red light emitting diodes. The HLMP-3850/-3490/-1440 Series are Gallium Arsenide Phosphide on Gallium Phosphide yellow light emitting diodes. The HLMP-3950/-3590/-3960/-1540/-D640/-K640 Series Lamps are Gallium Phosphide green light emitting diodes.

### Features

- Improved brightness
- Improved color performance
- Available in popular T-1 and T-1<sup>3</sup>/<sub>4</sub> packages
- New sturdy leads
- IC compatible/low current capability
- Reliable and rugged
- Choice of 3 bright colors  
High Efficiency Red  
High Brightness Yellow  
High Performance Green

### Applications

- Lighted switches
- Backlighting front panels
- Light pipe sources
- Keyboard indicators

## Selection Guide

Package Description	Color	Luminous Intensity Iv (mcd) @ 20mA				2q1/2 Degree	Package Outline
		Device HLMP-	Min.	Typ.	Max.		
T-1 <sup>3/4</sup>	Red	3707-L00xx	90.2	-	-	24	F
		3750	90.2	125.0	-	24	A
		3750-L00xx	90.2	125.0	-	24	A
	Yellow	3807-K00xx	96.2	-	-	24	F
		3850	96.2	140.0	-	24	A
		3850-K00xx	96.2	140.0	-	24	A
		3850-KL0xx	96.2	150.0	294.0	24	A
	Green	3907-K00xx	111.7	-	-	24	F
		3914-K00xx	111.7	-	-	24	D
		3950	111.7	265.0	-	24	A
		3950-K00xx	111.7	265.0	-	24	A
		3950-LM0xx	170.0	300.0	490.0	24	A
		3960-K0xxx	111.7	265.0	-	24	E
	Emerald Green	D640-E00xx	6.7	21.0	-	24	D
	T-1 <sup>3/4</sup> Low Profile	Red	3390	35.2	55.0	-	32
Yellow		3490	37.6	55.0	-	32	B
		3490-I00xx	37.6	55.0	-	32	B
Green		3590	43.6	55.0	-	32	B
		3590-I00xx	43.6	55.0	-	32	B
T-1	Red	1340	35.2	55.0	-	45	C
		1340-H00xx	8.6	15.0	27.6	45	C
		1340-J00xx	35.2	55.0	-	45	C
		1340-JK0xx	35.2	55.0	112.8	45	C
	Yellow	1440	23.5	45.0	-	45	C
		1440-H00xx	23.5	45.0	-	45	C
		1440-HI0xx	23.5	-	75.2	45	C
		1440-HIB00	23.5	-	75.2	45	C
	Green	1540	27.3	45.0	-	45	C
		1540-H00xx	27.3	45.0	-	45	C
		1540-IJ0xx	43.6	60.0	139.6	45	C
	Emerald Green	K640	4.2	21.0	-	45	C
		K640-D00xx	4.2	21.0	-	45	C
		K640-FGNxx	10.6	20.0	34.0	45	C

# Package Dimensions

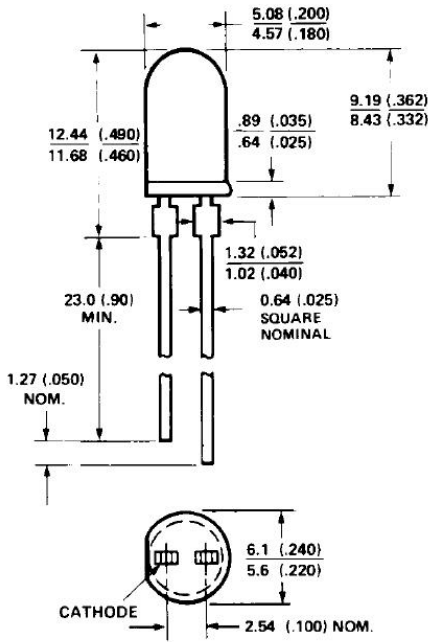

**PACKAGE OUTLINE "A"**  
HLMP-3750, -3850, -3950

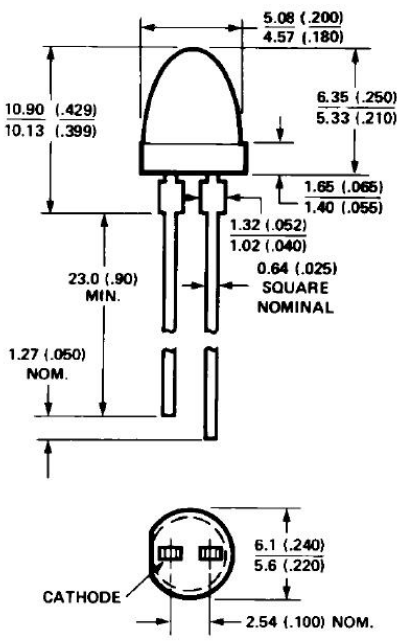

**PACKAGE OUTLINE "B"**  
HLMP-3390, -3490, -3590

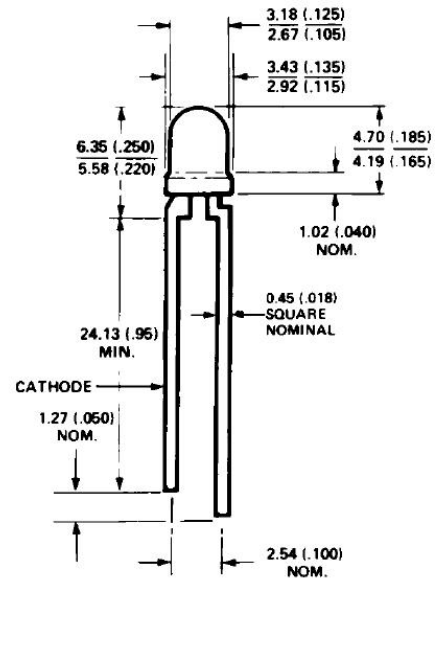

**PACKAGE OUTLINE "C"**  
HLMP-1340, -1440, -1540

**NOTES:**  
1. ALL DIMENSIONS ARE IN MILLIMETERS (INCHES).  
2. AN EPOXY MENISCUS MAY EXTEND ABOUT 1 mm (0.040") DOWN THE LEADS.

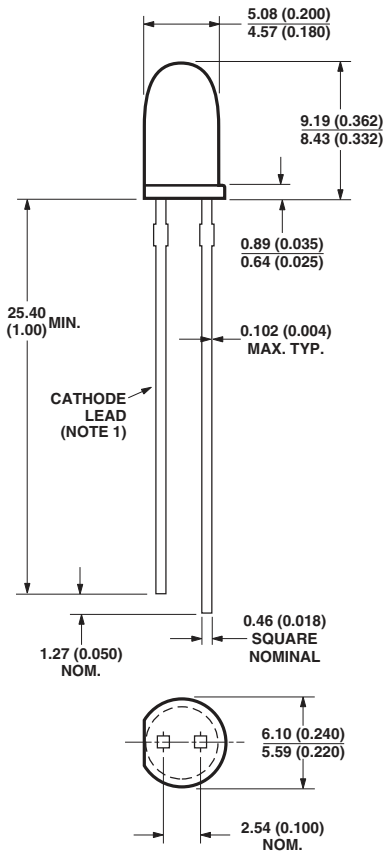

**PACKAGE OUTLINE "D"**  
HLMP-D640

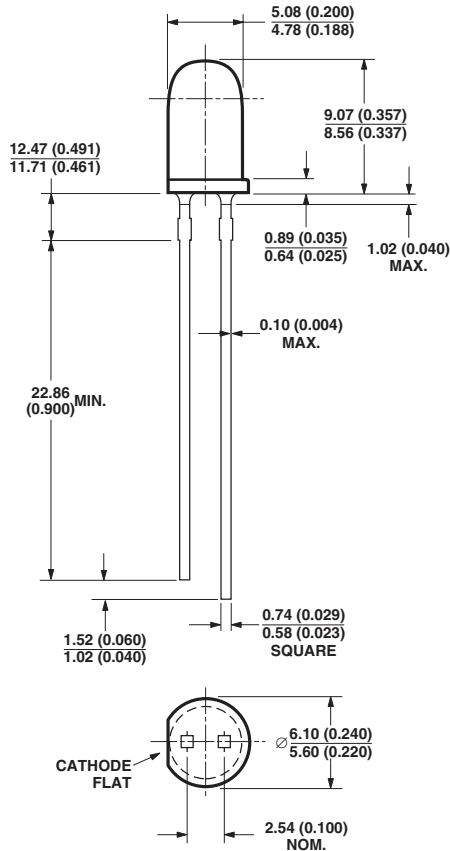

**PACKAGE OUTLINE "E"**  
HLMP-3960

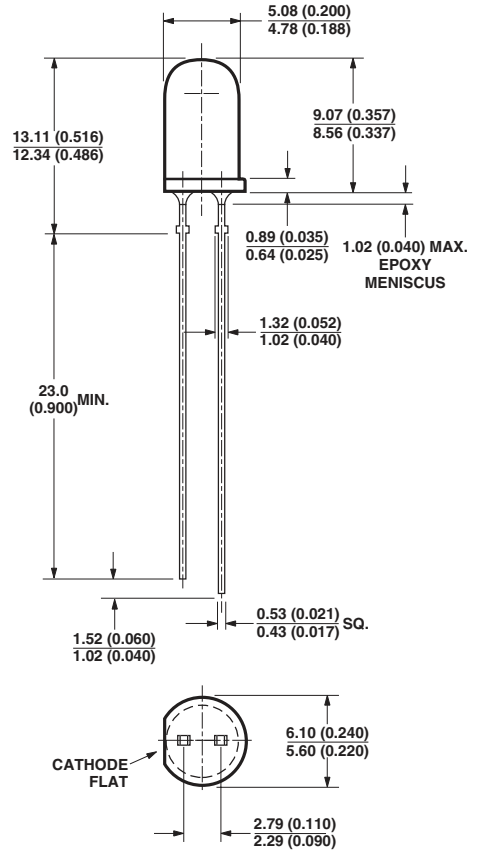

**PACKAGE OUTLINE "F"**  
HLMP-3707/-3807/-3907

## Part Numbering System

HLMP - x x xx - x x x xx

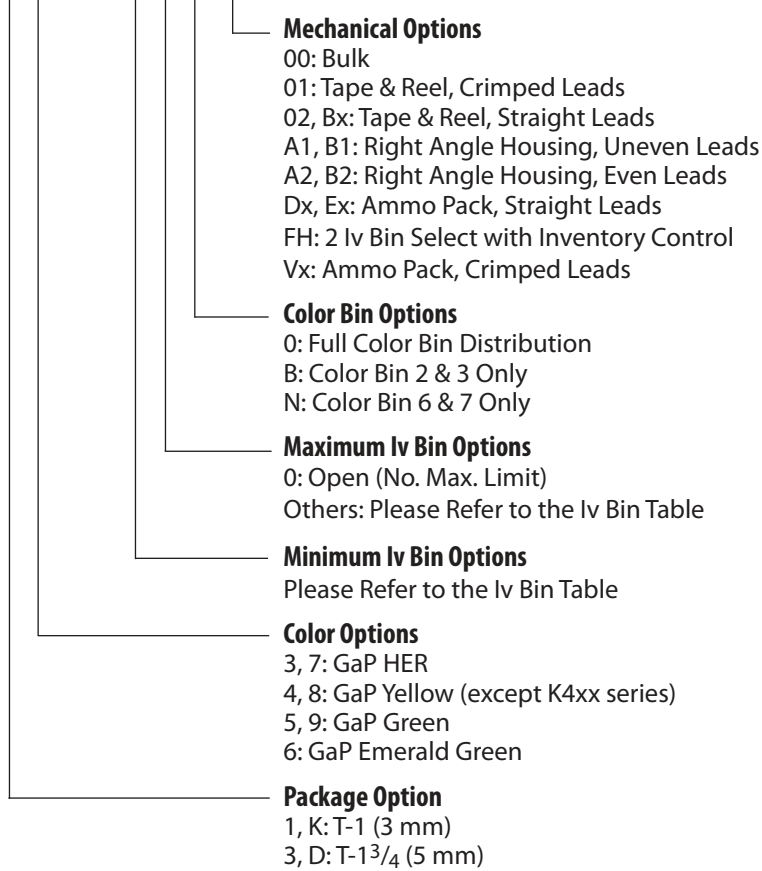

## Absolute Maximum Ratings at $T_A = 25^\circ\text{C}$

Parameter	Red	Yellow	Green/Emerald Green	Units
Peak Forward Current	90	60	90	mA
Average Forward Current <sup>[1]</sup>	25	20	25	mA
DC Current <sup>[2]</sup>	30	20	30	mA
Transient Forward Current <sup>[3]</sup> (10 $\mu\text{s}$ Pulse)	500	500	500	mA
Reverse Voltage ( $I_R = 100 \mu\text{A}$ )	5	5	5	V
LED Junction Temperature	110	110	110	$^\circ\text{C}$
Operating Temperature Range	-40 to +100	-40 to +100	-20 to +100	$^\circ\text{C}$
Storage Temperature Range	-40 to +100	-40 to +100	-40 to +100	$^\circ\text{C}$

### Notes:

- See Figure 2 to establish pulsed operating conditions.
- For Red and Green series derate linearly from  $50^\circ\text{C}$  at  $0.5 \text{ mA}/^\circ\text{C}$ . For Yellow series derate linearly from  $50^\circ\text{C}$  at  $0.2 \text{ mA}/^\circ\text{C}$ .
- The transient peak current is the maximum non-recurring peak current the devices can withstand without damaging the LED die and wire bonds. It is not recommended that the device be operated at peak currents beyond the Absolute Maximum Peak Forward Current.

### Electrical/Optical Characteristics at $T_A = 25^\circ\text{C}$

Symbol	Description	T-1 <sup>3/4</sup>	T-1 <sup>3/4</sup> Low Dome	T-1	Min.	Typ.	Max.	Units	Test Conditions	
$\lambda_{\text{PEAK}}$	Peak Wavelength	37xx	3390	1340		635		nm	Measurement at Peak	
		38xx	3490	1440		583				
		39xx	3590	1540		565				
		D640		K640		558				
$\lambda_d$	Dominant Wavelength	37xx	3390	1340		626		nm	Note 1	
		38xx	3490	1440		585				
		39xx	3590	1540		569				
		D640		K640		560				
$\Delta\lambda^{3/4}$	Spectral Line Halfwidth	37xx	3390	1340		40		nm		
		38xx	3490	1440		36				
		39xx	3590	1540		28				
		D640		K640		24				
$\tau_s$	Speed of Respond	37xx	3390	1340		90		ns		
		38xx	3490	1440		90				
		39xx	3590	1540		500				
		D640		K640		3100				
C	Capacitance	37xx	3390	1340		11		pF	$V_F = 0,$ $f = 1 \text{ MHz}$	
		38xx	3490	1440		15				
		39xx	3590	1540		18				
		D640		K640		35				
$R\theta_{\text{J-PIN}}$	Thermal Resistance	37xx	3390			210		$^\circ\text{C/W}$	Junction to Cathode Lead	
		38xx	3490			210				
		39xx	3590			210				
		D640				510				
					1340		290			
					1440		290			
					1540		290			
					K640		290			
$V_F$	Forward Voltage	37xx	3390	1340	1.5	1.9	2.6	V	$I_F = 20 \text{ mA}$ (Figure 3)	
		38xx	3490	1440	1.5	2.1	2.6			
		39xx	3590	1540	1.5	2.2	3.0			
		D640		K640		2.2	3.0			
$V_R$	Reverse Breakdown Voltage	37xx	3390	1340	5.0			V	$I_F = 100 \mu\text{A}$	
		38xx	3490	1440						
		39xx	3590	1540						
		D640		K640						
$\eta_V$	Luminous Efficacy	37xx	3390	1340		145		<u>lumens</u> watt	Note 2	
		38xx	3490	1440		500				
		39xx	3590	1540		595				
		D640		K640		655				

Notes:

- The dominant wavelength,  $\lambda_d$ , is derived from the CIE chromaticity diagram and represents the single wavelength which defines the color of the device.
- The radiant intensity,  $I_e$ , in watts per steradian, may be found from the equation  $I_e = IV/\eta_V$ , where  $IV$  is the luminous intensity in candelas and  $\eta_V$  is the luminous efficacy in lumens/watt.

## Red, Yellow, and Green

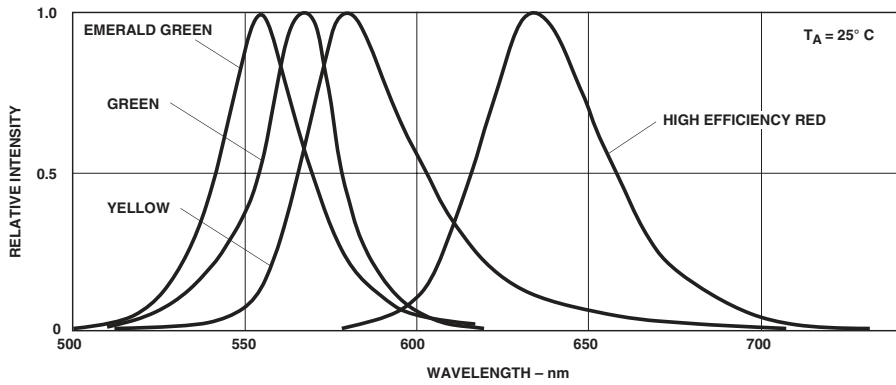

Figure 1. Relative intensity vs. wavelength.

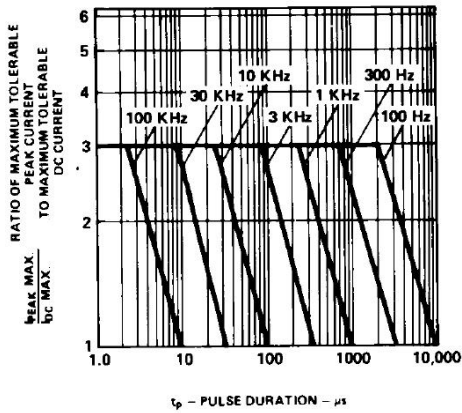

Figure 2. Maximum tolerable peak current vs. pulse duration. ( $I_{DC}$  MAX as per MAX ratings).

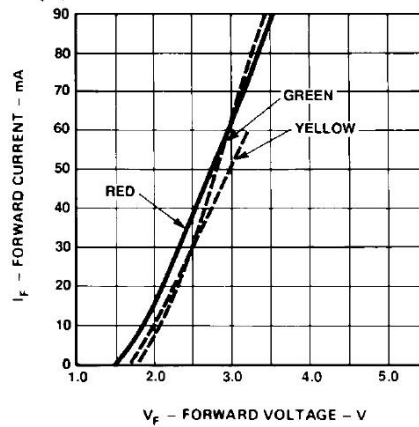

Figure 3. Forward current vs. forward voltage.

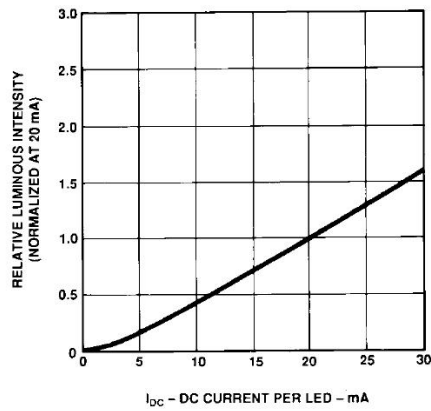

Figure 4. Relative luminous intensity vs. forward current.

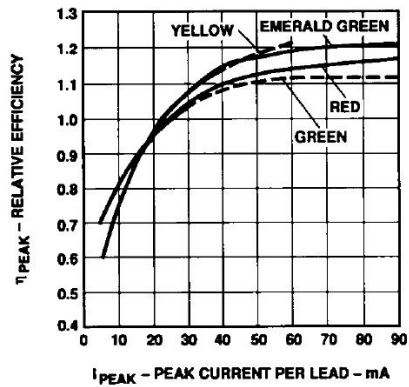

Figure 5. Relative efficiency (luminous intensity per unit current) vs. peak current.

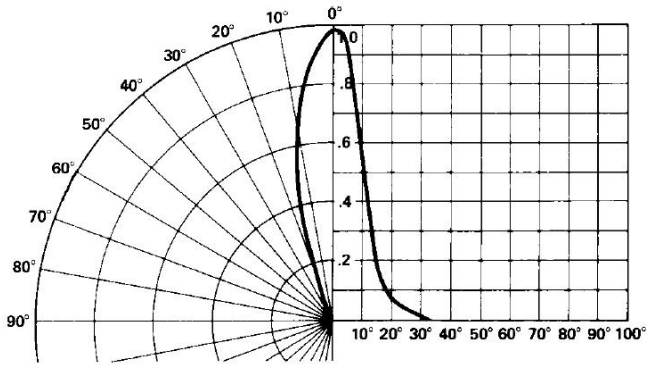

Figure 6. Relative luminous intensity vs. angular displacement.  
T-1<sup>3/4</sup> lamp.

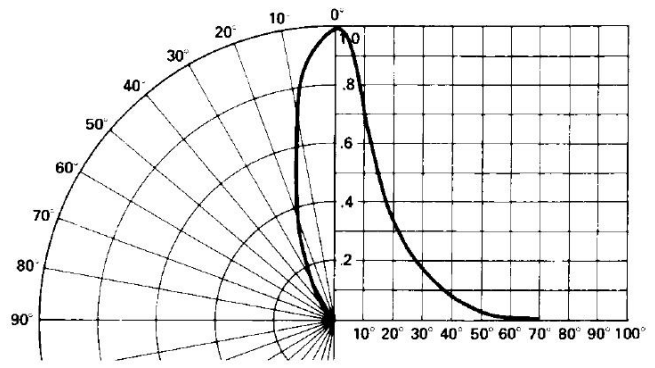

Figure 7. Relative luminous intensity vs. angular displacement.  
T-1<sup>3/4</sup> low profile lamp.

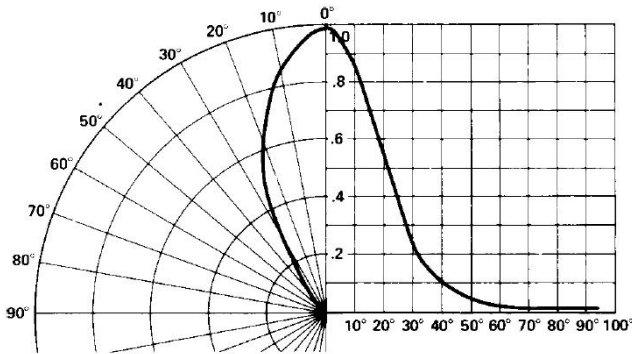

Figure 8. Relative luminous intensity vs. angular displacement.  
T-1 lamp.

### Intensity Bin Limits

Color	Bin	Intensity Range (mcd)	
		Min.	Max.
Red	G	9.7	15.5
	H	15.5	24.8
	I	24.8	39.6
	J	39.6	63.4
	K	63.4	101.5
	L	101.5	162.4
	M	162.4	234.6
	N	234.6	340.0
	O	340.0	540.0
	P	540.0	850.0
	Q	850.0	1200.0
	R	1200.0	1700.0
	S	1700.0	2400.0
	T	2400.0	3400.0
	U	3400.0	4900.0
	V	4900.0	7100.0
W	7100.0	10200.0	
X	10200.0	14800.0	
Y	14800.0	21400.0	
Z	21400.0	30900.0	

Maximum tolerance for each bin limit is  $\pm 18\%$ .

### Intensity Bin Limits (continued)

Color	Bin	Intensity Range (mcd)		
		Min.	Max.	
Yellow	H	26.5	42.3	
	I	42.3	67.7	
	J	67.7	108.2	
	K	108.2	173.2	
	L	173.2	250.0	
	M	250.0	360.0	
	N	360.0	510.0	
	O	510.0	800.0	
	P	800.0	1250.0	
	Q	1250.0	1800.0	
	R	1800.0	2900.0	
	S	2900.0	4700.0	
	T	4700.0	7200.0	
	U	7200.0	11700.0	
	V	11700.0	18000.0	
	W	18000.0	27000.0	
	Green/ Emerald	A	1.1	1.8
		B	1.8	2.9
	Green	C	2.9	4.7
D		4.7	7.6	
E		7.6	12.0	
F		12.0	19.1	
G		19.1	30.7	
H		30.7	49.1	
I		49.1	78.5	
J		78.5	125.7	
K		125.7	201.1	
L		201.1	289.0	
M		289.0	417.0	
N		417.0	680.0	
O		680.0	1100.0	
P		1100.0	1800.0	
Q		1800.0	2700.0	
R		2700.0	4300.0	
S		4300.0	6800.0	
T		6800.0	10800.0	
U		10800.0	16000.0	
V	16000.0	25000.0		
W	25000.0	40000.0		

Maximum tolerance for each bin limit is  $\pm 18\%$ .

### Color Categories

Color	Cat #	Lambda (nm)	
		Min.	Max.
Emerald Green	9	552.5	555.5
	8	555.5	558.5
	7	558.5	561.5
	6	561.5	564.5
Green	6	561.5	564.5
	5	564.5	567.5
	4	567.5	570.5
	3	570.5	573.5
	2	573.5	576.5
Yellow	1	582.0	584.5
	3	584.5	587.0
	2	587.0	589.5
	4	589.5	592.0
	5	592.0	593.0
Orange	1	597.0	599.5
	2	599.5	602.0
	3	602.0	604.5
	4	604.5	607.5
	5	607.5	610.5
	6	610.5	613.5
	7	613.5	616.5
	8	616.5	619.5

Maximum tolerance for each bin limit is  $\pm 0.5$  nm.



## Mechanical Option Matrix

Mechanical Option Code	Definition
00	Bulk Packaging, minimum increment 500 pcs/bag
01	Tape & Reel, crimped leads, min. increment 1300 pcs/bag for T-1 <sup>3/4</sup> , 1800 pcs/bag for T-1
02	Tape & Reel, straight leads, min. increment 1300 pcs/bag for T-1 <sup>3/4</sup> , 1800 pcs/bag for T-1
A1	T-1, Right Angle Housing, uneven leads, minimum increment 500 pcs/bag
A2	T-1, Right Angle Housing, even leads, minimum increment 500 psc/bag
B1	T-1 <sup>3/4</sup> , Right Angle Housing, uneven leads, minimum increment 500 pcs/bag
B2	T-1 <sup>3/4</sup> , Right Angle Housing, even leads, minimum increment 500 psc/bag
BJ	T-1, Tape & Reel, straight leads, minimum increment 2000 pcs/bag
EG	Ammo Pack, straight leads in 5 K increment
FH	Devices that require inventory control and 2 l <sub>v</sub> bin select
VR	Ammo Pack, crimped leads, min. increment 2 k for T-1 <sup>3/4</sup> and T-1

Note:

All categories are established for classification of products. Products may not be available in all categories. Please contact your local Avago representative for further clarification/information.

## Precautions:

### Lead Forming

- The leads of an LED lamp may be preformed or cut to length prior to insertion and soldering into PC board.
- If lead forming is required before soldering, care must be taken to avoid any excessive mechanical stress induced to LED package. Otherwise, cut the leads of LED to length after soldering process at room temperature. The solder joint formed will absorb the mechanical stress of the lead cutting from traveling to the LED chip die attach and wirebond.
- It is recommended that tooling made to precisely form and cut the leads to length rather than rely upon hand operation.

### Soldering Conditions

- Care must be taken during PCB assembly and soldering process to prevent damage to LED component.
- The closest LED is allowed to solder on board is 1.59 mm below the body (encapsulant epoxy) for those parts without standoff.
- Recommended soldering conditions:

Wave Soldering	Dipping	Manual Solder
Pre-heat Temperature	105 °C Max.	–
Pre-heat Time	30 sec Max.	–
Peak Temperature	250 °C Max.	260 °C Max.
Dwell Time	3 sec Max.	5 sec Max.

- Wave soldering parameter must be set and maintained according to recommended temperature and dwell time in the solder wave. Customer is advised to periodically check on the soldering profile to ensure the soldering profile used is always conforming to recommended soldering condition.
- If necessary, use fixture to hold the LED component in proper orientation with respect to the PCB during soldering process.
- Proper handling is imperative to avoid excessive thermal stresses to LED components when heated. Therefore, the soldered PCB must be allowed to cool to room temperature, 25°C, before handling.
- Special attention must be given to board fabrication, solder masking, surface plating and lead holes size and component orientation to assure solderability.
- Recommended PC board plated through hole sizes for LED component leads:

LED Component Lead Size	Diagonal	Plated Through Hole Diameter
0.457 x 0.457 mm (0.018 x 0.018 inch)	0.646 mm (0.025 inch)	0.976 to 1.078 mm (0.038 to 0.042 inch)
0.508 x 0.508 mm (0.020 x 0.020 inch)	0.718 mm (0.028 inch)	1.049 to 1.150 mm (0.041 to 0.045 inch)

Note: Refer to application note AN1027 for more information on soldering LED components.

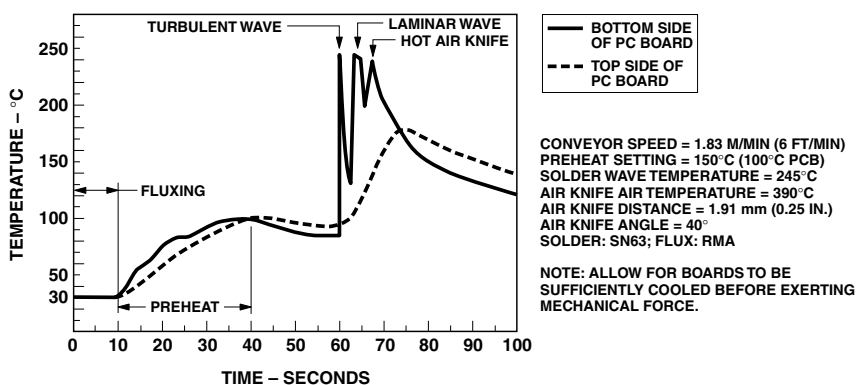

Figure 8. Recommended wave soldering profile.

For product information and a complete list of distributors, please go to our web site: [www.avagotech.com](http://www.avagotech.com)

Avago, Avago Technologies, and the A logo are trademarks of Avago Technologies in the United States and other countries. Data subject to change. Copyright © 2005-2008 Avago Technologies. All rights reserved. Obsoletes 5989-4254EN AV02-1556EN - October 13, 2008

**AVAGO**  
TECHNOLOGIES