



(MPM-90)



(MPM-90-xxST)



ANSI/AAMI ES60601-1 BS EN/EN60601-1 IEC60601-1 TPTC004

■ Features

- 3.43"x2.05" compact size
- PCB, chassis or screw terminal mounting version
- Medical safety approved (2 x MOPP) according to ANSI/AAMI ES60601-1 and IEC/BS EN/EN60601-1
- Suitable for BF application with appropriate system consideration
- No load power consumption < 0.1W
- Extremely low leakage current
- Wide operating temp. range -30 ~ +80°C
- EMI Class B without additional components
- Isolation Class II
- Protections: Short circuit / Overload / Over voltage
- No minimum load required
- Operating altitude up to 4000 meters(Note.7)
- 100W peak(10 sec.)
- 3 years warranty

■ Applications

- Portable medical device
- Mobile clinical workstation
- Medical computer monitor
- Medical examination instrument

■ GTIN CODE

MW Search: <https://www.meanwell.com/serviceGTIN.aspx>

■ Description

MPM-90 is a 90W high density and small size (87x52x29.5mm) AC/DC PCB-mount module type medical grade power supply . It features the operation for 80~264VAC, a low no load power consumption less than 0.1W, a high efficiency up to 93%, Class II (no FG) double insulation, outstanding dissipation, 2~5G anti-vibration by model, high EMC performance, 4KVAC isolation, etc. The design observes IEC/BS EN/EN60601-1 and ANSI/AAMI ES60601-1 version three with 2 x MOPP level and ultra-low leakage current (<100µA). It is very suitable for BF (patient contact) type medical device or relevant equipment.

■ Model Encoding

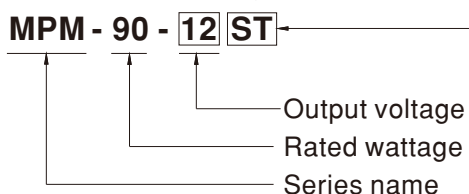

- { Blank : PCB mounting style
- { ST : Screw terminal style



SPECIFICATION

MODEL		MPM-90-12 <input type="checkbox"/>	MPM-90-15 <input type="checkbox"/>	MPM-90-24 <input type="checkbox"/>	MPM-90-48 <input type="checkbox"/>	
OUTPUT	DC VOLTAGE	12V	15V	24V	48V	
	CURRENT	Peak(10 sec.)	7.37A	6.23A	4.13A	2.07A
		Convection	6.7A	5.67A	3.75A	1.88A
	RATED POWER	Peak(10 sec.) ^{Note.2}	88.4W	93.5W	99W	99.2W
		Convection	80.4W	85.05W	90W	90.2W
	RIPPLE & NOISE (max.) ^{Note.3}	120mVp-p	150mVp-p	200mVp-p	240mVp-p	
	VOLTAGE TOLERANCE ^{Note.4}	±2.0%	±2.0%	±2.0%	±2.0%	
	LINE REGULATION	±0.5%	±0.5%	±0.5%	±0.5%	
	LOAD REGULATION	±1.0%	±0.5%	±0.5%	±0.5%	
	SETUP, RISE TIME	1000ms, 30ms/230VAC	1000ms, 30ms/115VAC at full load			
HOLD UP TIME (Typ.)	30ms/230VAC	10ms/115VAC at full load				
INPUT	VOLTAGE RANGE ^{Note.5}	80 ~ 264VAC 113 ~ 370VDC				
	FREQUENCY RANGE	47 ~ 63Hz				
	EFFICIENCY (Typ.)	92%	92.5%	93%	93%	
	AC CURRENT (Typ.)	1.9A/115VAC	1.1A/230VAC			
	INRUSH CURRENT (Typ.)	COLD START	30A/115VAC	65A/230VAC		
	LEAKAGE CURRENT (max.) ^{Note.6}	Touch current <100µA/264VAC				
PROTECTION	OVERLOAD	115% ~ 160% rated output power Protection type : Hiccup mode, recovers automatically after fault condition is removed				
	OVER VOLTAGE	12.6 ~ 16.2V	15.8 ~ 20.3V	25.2 ~ 32.4V	50.4 ~ 64.8V	
	OVER TEMPERATURE	Protection type : Shut down o/p voltage, re-power on to recover				
ENVIRONMENT	WORKING TEMP.	-30 ~ +80°C (Refer to "Derating Curve")				
	WORKING HUMIDITY	20 ~ 90% RH non-condensing				
	STORAGE TEMP.	-40 ~ +85°C				
	TEMP. COEFFICIENT	±0.03%/°C (0 ~ 50°C)				
	SOLDERING TEMPERATURE	Wave soldering: 265°C, 5s (max.); Manual soldering: 390°C, 3s (max.)				
	VIBRATION	Blank: 10 ~ 500Hz, 2G 10min./1cycle, period for 60min. each along X, Y, Z axes ST: 10 ~ 500Hz, 5G 10min./1cycle, period for 60min. each along X, Y, Z axes				
	OPERATING ALTITUDE ^{Note.7}	4000 meters / OVC II				
SAFETY & EMC (Note 8)	SAFETY STANDARDS	IEC60601-1, BS EN/EN60601-1, EAC TP TC 004, UL ANSI/AAMI ES60601-1(3.1 version), CAN/CSA-C22 3 rd Edition approved; Design refer to BS EN/EN60335-1(by request)				
	ISOLATION LEVEL	Primary-Secondary: 2xMOPP				
	WITHSTAND VOLTAGE	I/P-O/P: 4KVAC				
	ISOLATION RESISTANCE	I/P-O/P: 100M Ohms / 500VDC / 25°C / 70% RH				
	EMC EMISSION	Parameter	Standard		Test Level / Note	
		Conducted	BS EN/EN55011 (CISPR11)		Class B	
		Radiated	BS EN/EN55011 (CISPR11)		Class B	
		Harmonic Current	BS EN/EN61000-3-2		Class A	
		Voltage Flicker	BS EN/EN61000-3-3		-----	
	EMC IMMUNITY	BS EN/EN55035, BS EN/EN60601-1-2				
		Parameter	Standard		Test Level / Note	
		ESD	BS EN/EN61000-4-2		Level 4, 15KV air ; Level 4, 8KV contact	
		RF field susceptibility	BS EN/EN61000-4-3		Level 3, 10V/m(80MHz~2.7GHz) Table 9, 9~28V/m(385MHz~5.78GHz)	
		EFT bursts	BS EN/EN61000-4-4		Level 3, 2KV	
Surge susceptibility		BS EN/EN61000-4-5		Level 3, 1KV/Line-Line		
Conducted susceptibility		BS EN/EN61000-4-6		Level 3, 10V		
Magnetic field immunity		BS EN/EN61000-4-8		Level 4, 30A/m		
Voltage dip, interruption	BS EN/EN61000-4-11		>95% dip 0.5 periods, 30% dip 25 periods, >95% interruptions 250 periods			
OTHERS	MTBF	4548.9K hrs min. Telcordia SR-332 (Bellcore) ; 570.5K hrs min. MIL-HDBK-217F (25°C)				
	DIMENSION	PCB mounting style : 87*52*29.5mm (L*W*H)		Screw terminal style : 109*52*33.5mm (L*W*H)		
	PACKING	PCB mounting style : 0.197Kg;60pcs/12.8Kg/0.94CUFT		Screw terminal style : 0.219Kg;50pcs/12Kg/0.56CUFT		
NOTE	<p>1. All parameters NOT specially mentioned are measured at 230VAC input, rated load and 25°C of ambient temperature.</p> <p>2. 33% Duty cycle maximum within every 30 seconds. Average output power should not exceed the rated power.</p> <p>3. Ripple & noise are measured at 20MHz of bandwidth by using a 12" twisted pair-wire terminated with a 0.1µf & 47µf parallel capacitor.</p> <p>4. Tolerance : includes set up tolerance, line regulation and load regulation.</p> <p>5. Derating may be needed under low input voltages. Please check the derating curve for more details.</p> <p>6. Touch current was measured from primary input to DC output.</p> <p>7. The ambient temperature derating of 3.5°C/1000m with fanless models and of 5°C/1000m with fan models for operating altitude higher than 2000m(6500ft).</p> <p>8. The power supply is considered a component which will be installed into a final equipment. The final equipment must be re-confirmed that it still meets EMC directives. For guidance on how to perform these EMC tests, please refer to "EMI testing of component power supplies." (as available on http://www.meanwell.com)</p> <p>※ Product Liability Disclaimer : For detailed information, please refer to https://www.meanwell.com/serviceDisclaimer.aspx</p>					

Block Diagram

fosc : 70KHz

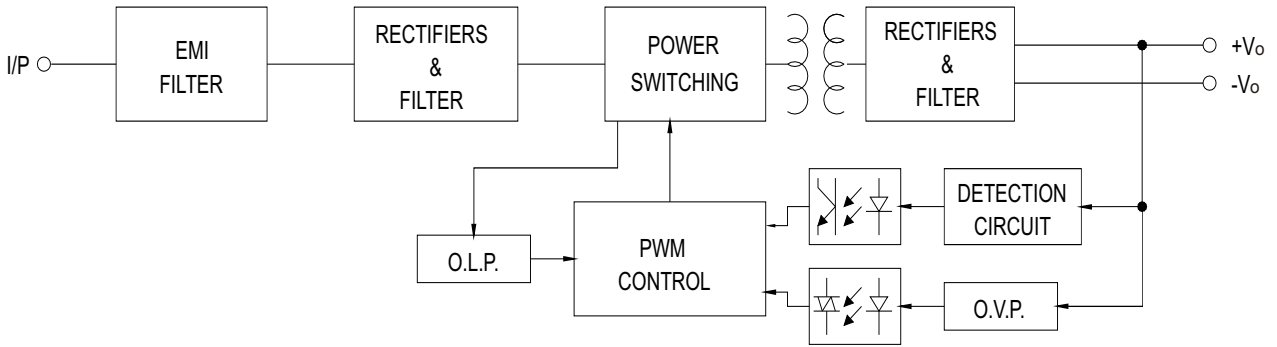

Derating Curve

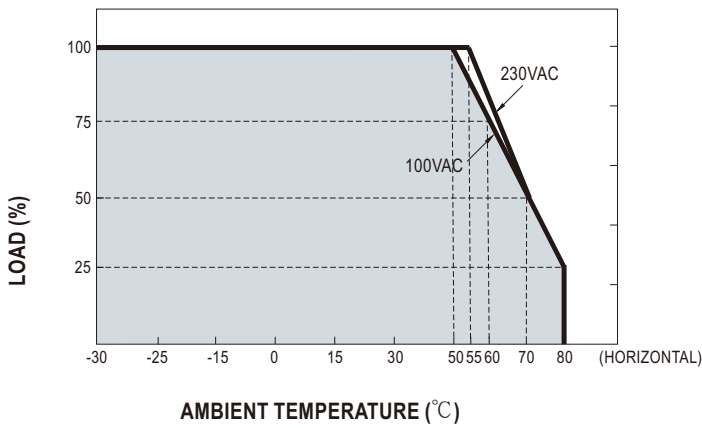

Output Derating VS Input Voltage

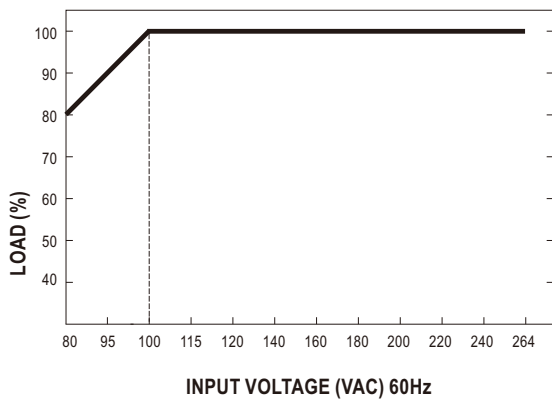

■ **Mechanical Specification**

Case No.IRM60 Unit:mm

• PCB mounting style (MPM - 90)

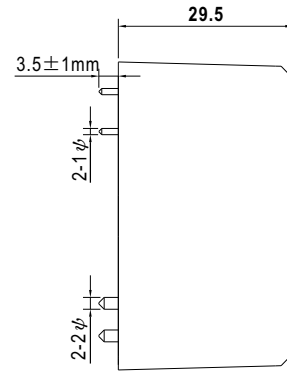
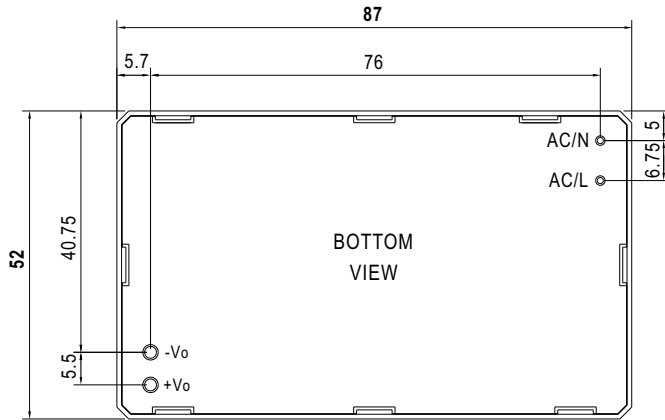

AC/L, AC/N P/N diameter: 1 φ
+Vo, -Vo P/N diameter: 2 φ

• Screw terminal style (MPM-90-xxST)

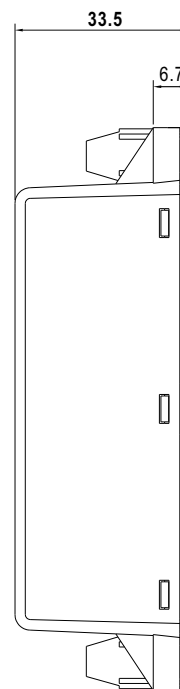
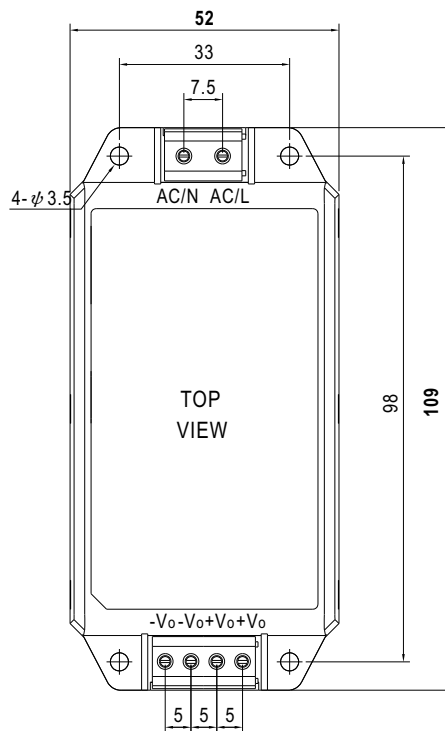

■ **Installation Manual**

Please refer to : <http://www.meanwell.com/manual.html>