



OLYMPIAN MODEL 740 Operation and Service Manual

P/N 133911-102

FCI MANUAL P/N 133865-001

Data herein has been verified and validated and believed adequate for the intended use. If the machine or procedures are used for purposes beyond the capabilities specified, FCI does not guarantee results and assumes no obligation or liability. This publication is not a license to operate under, nor a recommendation to infringe upon, any process patents.



OLYMPIAN MODEL 740



Table of Contents

INTRODUCTION	4
Scope of Manual	4
Machine Function (Press)	4
Specifications	4
Safety Precautions	5
INSTALLATION	7
General	7
Installation Precautions	7
Tools and Accessories	7
Machine Inspection	7
Machine Placement	7
Electrical Hook-Up	8
Terminal Guide Plate Assembly – Side Feed	8
Terminal Guide Plate Assembly – End Feed	8
Reel Bracket	9
Safety Guard	10
OPERATION	11
General	11
Controls and Indicators	11
Press Cycle Description	11
Manual Cycling of Press – PIC Installed	11
Manual Cycling Press – without PIC	11
Semi-Automatic Operation	12
SERVICE	13
PIC Changeover – End Feed	13
PIC Changeover – Side Feed	14
Ram Height Adjustment	15
Brake Adjustment	16
Belt Inspection	17
Belt Adjustment	17
Flywheel	18
Service	19
Parts Replacement	19
Troubleshooting Chart	20

REFERENCE DRAWINGS

133911-001	EPL, Olympian 740 X-View, Figure 8
133927-001	OL740 Electrical Schematic
144758-001	Electrical Schematic OL740 – (4 Pole Power Switch)

REFERENCE DOCUMENTS Delete any form references below that are not needed:

- FORM #E-3245 - -Customer Application Machine Warranty and Service Policy**
“Section I” Equipment owned by FCI Electronics.
- FORM #E-3244 - -Customer Application Machine Warranty and Service Policy**
“Section II” Equipment purchased by the customer.
- FORM # E-3247 - - FCI Electronics Address List**



Introduction

Scope of Manual

This manual contains the information necessary to understand, install, operate, maintain, and order parts for the OLYMPIAN Model 740. This information is intended for use by both operator and service personnel. However, certain procedures within the manual should be performed by service personnel only: these procedures are identified by a warning instruction. The table of contents in the front of the manual gives a paragraph-by-paragraph breakdown of the subject matter covered in each section.

WARNINGS, CAUTIONS, and NOTES within the text of this manual are used to emphasize important and critical instructions.

WARNING: An operating procedure, practice, etc. which, if not carefully followed, could result in personal injury or affect the operator's health.

CAUTION: An operation procedure, practice, etc. which, if not strictly observed, could result in damage of equipment.

NOTE: An operating procedure, condition, etc. which it is essential to highlight.

We recommend that operator or service personnel responsible for maintenance of the Model 740 become thoroughly familiar with all aspects of the machine's construction and operation. If operational or maintenance problems arise which are beyond the scope of this manual, contact your district service representative.

Machine Function (Press)

The OLYMPIAN Model 740 is a semi-automatic bench press with a rolling clutch providing high production speed. With a properly installed **P**recision **I**nterchangeable **C**rimper (PIC), this unit provides a stable, high quality, discrete crimp-to-wire termination.

Specifications

General

Dimensions (allowing for 24 inch reel of terminals)

- Length..... 71.1 cm (28 in.)
- Width Front and Rear Cover Open 78.7 cm (31 in.)
- Width 55.8 cm (22 in.)
- Width with Side Guard Open 93.9 cm (37 in.)
- Height 111.7 cm (44 in.)
- Weight 95 kg (209 lbs.)
- Application Rate 2,400 per hour (depending on operator dexterity)



Electrical Requirements

- Power..... 115V ac, 60Hz 1 Phase
- Motor..... 115V ac, 50/60 Hz. 1730 RPM
4 PH – 6.1 A – Capacitor Start Motor
185 uf Capacitor
- Fuse 10A
- Power Cord Length 1.8 m (6 ft.)
- Press Rating 1814 Kg (2 Ton)

CAUTION: Wire Color-coding in press may not comply with J.I.C. Standards.

Safety Precautions

Press must be bolted to a sturdy workbench utilizing four boltholes in the casting base. This is required to prevent press from vibrating and possibility falling from bench.

Turn power switch to the OFF position **before** opening hinged doors of the safety guard, and before making any adjustments.

WARNING: To avoid the possibility of an electrical shock. Disconnect the power cord from its outlet before opening the front door of the press.

The hand crank, for manual cycling the press, is fitted with an internal spring. When the inward pressure is released from the hand crank, it should disengage from the crankshaft of the press.

WARNING: The hand crank must be removed from the crankshaft before the power switch is switched to the **ON** position to prevent bodily injury or damage to the equipment.

After rotating the crankshaft by hand and before switching the press' power switch to the **ON** position, make sure that the mark on the square-ended shaft at the rear of the press is in alignment with the 0° mark (refer to Figure 1). Failure to properly position the mark will cause a rattling noise when the power is moved to the **ON** position or could cause the fuse to blow.

WARNING: Personnel other than maintenance should never operate the bench press without the safety guard in the closed position.

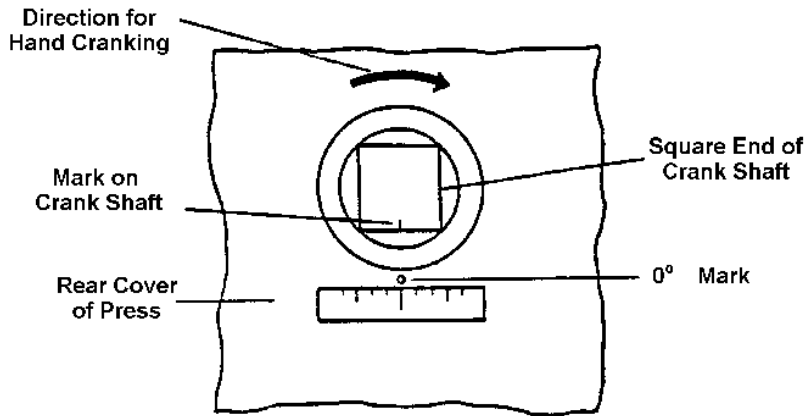

Figure 1

Installation

General

This section provides the information necessary to inspect, install, and prepare the OLYMPIAN Model 740 for operation. Before the machine is installed, you should become familiar with the Installation and Service Policies provided in the back of this manual.

The initial installation of application machines is the responsibility of the FCI Field Service Representative. During installation, the Service representative will demonstrate how to operate and maintain the machine, and is available to assist with any future operation or service problems.

Installation Precautions

Take the following precautions during machine installation:

- Avoid placing the machine in dusty locations and places where vibrations occur.
- Handle the machine carefully at all times.
- Never place the machine on a flimsy workbench.
- Wear lightweight leather gloves when handling equipment and terminals.

Tools and Accessories

The following is a list of tools and accessories supplied for the OLYMPIAN Model 740:

Reel Boss, Collar, spring, and Reel Stopper for Reel Bracket Hand Crank

A complete tool kit may be obtained by ordering Part Number 142487-001.

Machine Inspection

The OLYMPIAN Model 740 was inspected, adjusted, and tested before shipment. After the machine has been unpacked, place it on a sturdy workbench where it is easily accessible for inspection.

Inspect all items for possible damage that may have occurred during shipment. Check for dents, broken knobs, switches, etc. If damage or missing items are found, notify the carrier and the FCI District Sales Office. Retain any shipping containers in case repacking is necessary.

Machine Placement

The operators' comfort is an important factor in operating the Model 740 safely. In order to reduce operation fatigue and increase productivity, consideration should be given to the placement of the machine.



- The front edge of the machine should be six to eight inches from the front edge of the workbench in order to prevent discomfort to the operator.
- Allow room to obtain access to the back and sides of the machine for servicing.
- Secure press to workbench, possibly using the carriage bolts (5-16 in. X 2.5 in. long with washer and nut) that were used to fasten the press to the pallet for shipment.

Electrical Hook-Up

WARNING: The power switch on the press should be in the **OFF** position prior to electrical connection to prevent possible bodily injury by premature operation.

Connect the power cord to an 115V, 60 Hz grounded outlet.

Terminal Guide Plate Assembly – Side Feed

(Refer to drawing and EPL 133911)

Installation

- Turn bar for guide plate mounting (57), with terminal guide plate (48) assembly attached, into threaded hole on left side of frame (58).
- To tighten bar (57) to the frame, place wrench onto the flats provided and turn.
- If the terminal guide plate (48) is not aligned properly, loosen the two cap screws in the clamp and align. Retighten cap screws.

Removal

- Place wrench onto the flats on the bar (57) and loosen.
- Rotate the bar (57) with terminal guide plate assembly attached, until removed from the frame (58).

Terminal Guide Plate Assembly – End Feed

(Refer to drawing and EPL 133911)

Installation

- Turn bar for guide plate mounting (57), with terminal guide plate assembly attached, into threaded hole on the back of the rear cover (60).
- To tighten bar (57) to the frame, place wrench onto the flats provided and turn.
- If the terminal guide plate (48) is not aligned properly loosen the two cap screws in the clamp and align. Retighten cap screws.

Removal

- Place wrench onto the flats on the bar (57) and loosen.
- Rotate the bar (57) with terminal guide plate assembly attached, until removed from the frame (58).

Reel Bracket

(Refer to drawing and EPL 133911)

Side Feed

- Position reel bracket (49) as shown and tighten cap screws on right of frame (58) against flat on bracket.
- Install the rear reel boss (50), with clamp bolt (52) attached, then the spring (53) and collar (54).
- Install reel of terminals so that terminals unreel from the left side, with the U-shaped barrels up.
- Then install reel stopper (51) and front reel boss (50 with clamp bolt (52) attached.
- Align reel of terminals so that it is centered with the slot in the PIC where the terminals enter.
- Next slide the rear reel boss with spring and collar against the reel and tighten clamp bolt.
- Then slide the reel stopper and the front reel boss against the reel with light tension. Tighten clamp bolt.

<p>NOTE: Too much tension on the reel could cause feed problems in the PIC. If there is not enough tension, terminals could unwind freely.</p>

End Feed

If reel bracket is positioned as shown:

- Loosen cap screw, which secures reel bracket (49), located on right side of frame (58).
- Pivot reel bracket assembly 90⁰ toward the right and tighten cap screw onto the flat of the bracket.
- Install the rear reel boss (50), with clamp bolt (52) attached, then the spring (53) and collar (54).
- Install reel of terminals so that terminals unreel with the U-shaped barrels up.

-
- Then install the front reel boss (50) with clamp bolt (52) attached.
 - Align reel of terminals so that it is centered with the slot in the PIC where the terminals enter.
 - Next, slide the rear reel boss with spring against the reel and tighten clamp bolt.
 - Then slide the front reel boss against the reel with light tension. Tighten clamp bolt.

NOTE: Too much tension on the reel could cause feed problems in the PIC. If there is not enough tension, terminals could unwind freely.

Safety Guard

- To open, remove cap screws, located on the upper right and left side of guard. Front and side will pivot open when lightly pulled at top of guards.
- To close, pivot front and side guard up and secure with cap screws.

Operation

General

This section provides the information necessary to operate the OLYMPIAN Model 740, and includes operating considerations and precautions.

Controls and Indicators

There are two **ON-OFF** switches on the front of the press: The top switch controls the counter; the bottom switch controls the power to operate the press. Both switches have indicator lamps, which are lighted when switches are in the **ON** position. The counter on the front of the press records the number of machine cycles.

The press is cycled when the foot switch is depressed.

Press Cycle Description

(Refer to Drawing and EPL 133911)

The exploded view shows the OLYMPIAN Model 740 bench press and its related parts. The drive motor (22) transmits power to the pulley (21) through the V-belt (29) to the flywheel (61), which drives the clutch assembly [retainer (2), roller (3), and clutch spring (4)]. The clutch assembly permits the power to be transmitted to the shaft (1), which rotates and causes arms (37), (38) and (39) to function; these three arms, in turn, causes the ram (36) to move down then up.

Manual Cycling of Press – PIC Installed

If the machine, as delivered, has PIC installed, refer to separate PIC instructions for start-up procedure prior to hand cycle.

Manual Cycling Press – without PIC

(Refer to Figure 1)

- With the power OFF, place hand crank onto the square end of the crankshaft at the rear of the machine.

NOTE: Continuously push in on the hand crank because of the internal spring.

- Rotating the crankshaft in the direction of the arrow, located on the outside of the rear cover (60) will lower and raise the ram. When under power, the flywheel rotates in the opposite direction of the arrow.
- Return crankshaft to the start position and continue turning slowly until a click sound is heard, indicating the stripper is properly engaged on the clutch. Then rotate the crankshaft in the opposite direction of this arrow until the mark on the end of the crankshaft is aligned with the 0° mark at the rear of the press.



-
- Remove hand crank from crankshaft before switching on power to the press.

WARNING: The hand crank must be removed for the crankshaft before the power switch is switched to the **ON** position to prevent injury or damage to the equipment.

Semi-Automatic Operation

(Refer to Figure 8)

- Move power switch to the **ON** position.
- Turn on light by turning switch at the top of the lamp assembly.
- Activate the counter by moving its switch to the **ON** position. Counter may be reset to zero by pushing in on tab (located on left side of the counter).
- Press and release the foot switch to complete one machine cycle.

Service

PIC Changeover – End Feed

(Refer to Drawing and EPL 133911)

Removal

- Move power switch to the **OFF** position.
- Disconnect power cord from electrical outlet.
- Open safety guard.
- Push the spring-loaded lever "C" (83) toward the rear of the machine to disengage it from lever "A" (79), and hold in this position.
- Move lever "A" (79) to the left, by pulling lever "B" (80), and release lever "C" (83).
- Slide the PIC to the rear. This releases the PIC from the press.

Installation

- Move lever "A" (79) to the left.
- Place the PIC on the base (76) to the rear of the ram bolt (87).
- Slide PIC forward, so the ram bolt (87) slides into the slot in shank "A" (102) of the PIC. (Refer to X view of PIC in the back of this manual.)
- Position the base plate of the PIC against the back and side of stopper "A" (77).
- Push the spring - loaded lever "C" (83) to the rear and hold in this position.
- Slide lever "A" (79) to the right, seating it in the slot on the side of the PIC base plate (101). (See X view of PIC.)
- Release lever "C" (83), which locks into lever "A" (79) to secure the PIC in position.
- Reconnect power cord to electrical outlet.
- Move power switch to the **ON** position.

NOTE: Refer to separate PIC instructions, in the back of this manual for start-up procedure.

PIC Changeover – Side Feed

(Refer to Drawing and EPL 133911)

Removal

- Move power switch to the **OFF** position.
- Disconnect power cord from electrical outlet.
- Open safety guard.
- Push the spring-loaded lever "C" (83) (located at the right-rear of the PIC) toward the back of the machine to disengage it from lever "A" (79), and hold in this position.
- Move lever "A" (79) (located on the left-side of the PIC) out, and release lever "C" (83). This frees the PIC from the base.
- Slide PIC to the left. This releases the PIC from the press.

Installation

- Move lever "A" (79) to the left.
- Place the PIC on the base (76) to the left of the ram bolt (87).
- Slide PIC to the right, so the ram bolt (87) slides into the slot in shank "A" (102) of the PIC. (Refer to X view of the PIC in the back of this manual.
- Position the base plate of the PIC against the back and side of stopper "A" (77).
- Push the spring-loaded lever "C" (83) to the rear and hold in this position.
- Slide lever "A" (79) to the right, seating it in the slot on the side of the base plate (101) of the PIC. (Refer to X view of PIC.)
- Release lever "C" (83), which locks into lever "A" (79) to secure the PIC in position.
- Reconnect power cord to electrical outlet.
- Move power switch to the **ON** position.

NOTE: Refer to separate PIC instructions, in the back of this manual for start-up procedure.

Ram Height Adjustment

Standard FCI Ram - (Refer to Figure 5)

- Move power switch to the **OFF** position.
- Open guard.
- Loosen the two cap screws, which clamp the set plate to the ram bolt.
- Insert the small end of the adjustment bar into a hole in the ram bolt and rotate the ram bolt to obtain approximate required shut height.

NOTE: The ram bolt has gradation marks etched on the side of it. Rotating the ram bolt one mark changes the ram height approximately 0.063 mm (0.0024 in.). As indicated on the label on the front of the press, rotating the ram bolt to the left lowers the ram height, rotating it to the right raises the ram height.

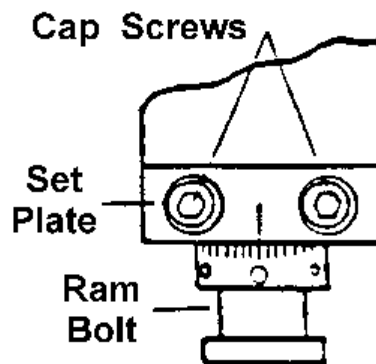

Figure 5

- Retighten the two cap screws on the set plate.
- Use crimp height dials on PIC for fine adjustment.
- Close guard.
- Move power switch to the **ON** position.

FCI Ram

- Move power switch to the **OFF** position.

- Open guard.
- Loosen ram jam nut.
- Rotate FCI Ram to the left to lower the ram or to the right to raise the ram to obtain approximate required shut height.
- Retighten ram jam nut.
- Use crimp height dials on PIC for fine adjustment.
- Close guard.
- Move power switch to the **ON** position.

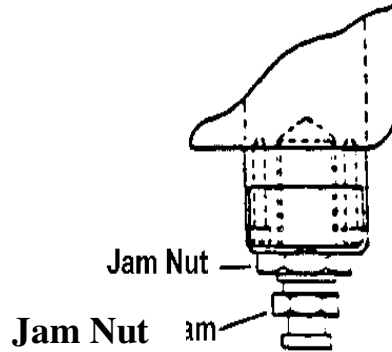

FCI Ram Figure 6

Brake Adjustment

(Refer to Drawing and EPL 133911)

If after a period of time, a rattling sound is detected from the press, follow instructions as described below:

- Mover power switch to the **OFF** position.
- Disconnect power cord from electrical outlet.
- Turn latch screw (30) counter clockwise until unscrewed from the frame (58).
- Open front cover "A" (59).

CAUTION: If brake is adjusted too tight, this will cause the press to operate slower and affect the production rate.

- Turn adjusting bolt (13) clockwise 1/4 turn. This tightens the brake (7) on the crankshaft (1), which prevents the crankshaft from drifting after the flywheel (61) is disengaged.
- Close front cover "A (59) and secure with latch screw (30).
- Connect power cord to electrical outlet.
- Turn press' power switch **ON** and cycle press. If the clicking sound has disappeared, the brake is adjusted properly. Continue operation. If the clicking is still present, follow steps as described above.

Belt Inspection

(Refer to Drawing and EPL 133911)

- Switch power switch to the **OFF** position.
- Disconnect power cord from the electrical outlet.
- Turn socket head cap screw (67) counter clockwise from the rear cover (60) and open cover.
- Check the V-belt. If it shows signs of excessive wear, fraying, or cracking, it should be replaced.

Belt Adjustment

(Refer to Drawing and EPL 133911)

- Push lightly on the V-belt. Tension is correct when the belt moves about one inch. If more movement is detected, continue with the following procedure.
- Loosen the four cap screws, which secures the motor (22) to the motor base (6).
- Push down on the motor while checking the amount of movement in the belt. The movement should be approximately one inch.
- Tighten the four screws to secure the motor. Recheck tension.
- Close rear cover (60) and tighten socket head cap screw (67).
- Connect power cord to electrical outlet.
- Move power switch to the **ON** position and continue operation.

Flywheel

(Refer to Drawing and EPL 133911)

Removal

- Move power switch to the **OFF** position.
- Disconnect power cord from the electrical outlet.
- Turn socket head cap screw (67) counter clockwise from the rear cover (60) and open cover.
- Remove V-belt (29) from the flywheel (61) and the motor pulley (21).
- Using snap ring pliers remove snap ring (32) and rear pulley bearing (25).
- Grasp flywheel firmly with both hands and pull outward. This will disengage the flywheel from the clutch assembly and crank shaft.

Installation

NOTE: Before attempting to replace the flywheel, be certain the rollers (3) are seated into the clutch (72). If not, the flywheel will not fit over the rollers.

- Grasp flywheel firmly with both hands, align the center hole in the flywheel with the retainer (2), and carefully push the flywheel onto the retainer.

CAUTION: The flywheel may come loose from the crankshaft if snap ring is not properly installed.

- Re-install pulley bearing (25). Then install the snap ring (32) using snap ring pliers. Check that snap ring is properly seated in its groove on the crankshaft.
- Re-install V-belt (29) onto the flywheel and motor pulley.
- Close rear cover (60) and secure with socket head cap screw (67).
- Manually cycle press; refer to paragraph 3-5.
- Connect power cord to the electrical outlet.
- Move power switch to the **ON** position and continue operation.

Monthly Maintenance

- Check power cords for broken wires or insulation.
- Check moving parts for wear.
- Check attaching hardware for tightness.
- Check V-belt for wear.
- Lubrication - (every 200 operating hours) Using a #1 Multi-purpose high grade grease, lubricate through the three grease nipples on the front cover "B" (5), one on the rear of the crank shaft (1) and one on arm "A" (37).

Service

In the event service or technical help is needed FCI Electronics provides a toll free number. For service or technical help call 1-800-843-6911.

Parts Replacement

- PARTS REPLACEMENT:
When calling for spare parts, have part number(s) ready for the customer service person. Number(s) can be obtained from the reference drawings located in the back of this manual. Spare part orders call 1-800-222-2194 and ask for CUSTOMER SERVICE.

Recommended spare parts for the bench press (EPL 133911) are specified in the parts list by the letters "SP" in the spare parts column.

For PIC spare parts, refer to the parts list for individual PIC.

Troubleshooting Chart

PROBLEM	POSSIBLE CAUSE	CORRECTIVE ACTION
Press will not cycle	Power cord is not connected to electrical outlet.	Connect power cord to electrical outlet.
	Power cord is not connected to press.	Connect power cord to press.
	Power switch is in the OFF position.	Move power switch to the ON position.
	Fuse blown.	Replace
	Foot switch is defective.	Replace
	Solenoid (23) is defective. (Fig.2)	Replace
	V-belt slipping on motor pulley.	Adjust V-belt as described in the Service Section, page 18
	Fatigued or broken clutch spring.	Replace
Machine double cycles	Stopper (15) is binding on holder (14) (Fig.2)	Lubricate - a few drops of light-weight oil.
Crimp height varies	Cap screw loose in the set plate.	Tighten cap screws.
	If press is fitted with adapter jam nut on ram is loose.	Tighten jam nut.
Fuse flows when power switch is moved to the ON position.	Mark on crankshaft is not aligned with 0°	Re-align crankshaft. Refer to Operation Section, page 12
Rattling sound from press	Mark on crankshaft is not aligned with 0°	Re-align crankshaft. Refer to Operation Section, page 12
	Brake is not adjusted correctly.	Adjust brake as described in the Service Section, page 17