

DO NOT SCALE FROM THIS PRINT

DESIGNED & DIMENSIONED IN MILLIMETERS [INCHES]

SEAF8-XX-05.0-XXX-XX-X-X-XX

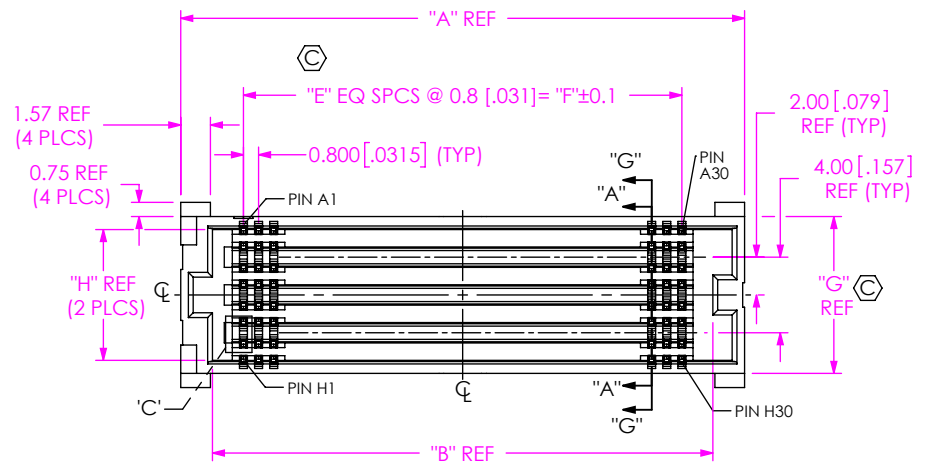

No. OF POSITIONS
-10, -20, -30, -40, -50 (PER ROW)

LEAD STYLE
-05.0= 5mm

PLATING SPECIFICATION
-S: .000030" SELECTIVE GOLD IN CONTACT AREA, MATTE TIN ON TAIL
-L: .000010" LIGHT SELECTIVE GOLD IN CONTACT AREA, MATTE TIN ON TAIL
-STL: .000030" SELECTIVE GOLD IN CONTACT AREA, TIN/LEAD ON TAIL (ONLY PAIRED WITH -1 SOLDER COMPOSITION & STYLE)

ROW
-04: 4 ROWS
-06: 6 ROWS
-08: 8 ROWS (SEE NOTE 10)
-10: 10 ROWS (SEE NOTE 10)

PACKAGING
BLANK: TAPE & REEL (SEE NOTES 4 & 13)
-FR: FULL REEL QTY TAPE & REEL (SEE NOTES 13 & 14)

SOLDER COMPOSITION & STYLE
-1: 63.0% TIN / 37.0% LEAD CHARGE TAIL (USE SUB-C-472-05.0-STL-1) (ONLY AVAILABLE WITH -STL PLATING)
*-2: 95.5% TIN / 3.8% SILVER/0.7% COPPER CHARGE TAIL (USE SUB-C-265-05.0-X-2)
-3: 95.5% TIN / 3.8% SILVER/0.7% COPPER CHARGE TAIL (USE SUB-C-472-05.0-X-2)

(* = FOR EXISTING CUSTOMERS ONLY)

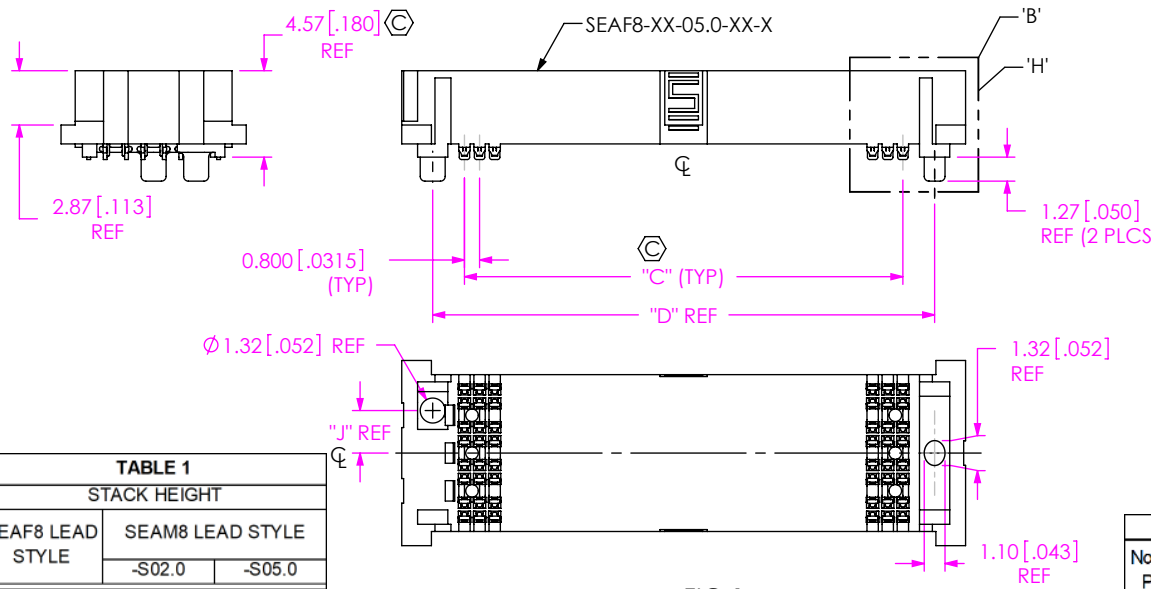

TABLE 3

-No. OF ROWS	"G"	"H"	"J"
-04	4.30 [0.169]	2.92 [0.115]	1.25 [0.049]
-06	6.30 [0.248]	4.92 [0.194]	2.25 [0.089]
-08	8.30 [0.327]	6.92 [0.272]	2.25 [0.089]
-10	10.30 [0.406]	8.92 [0.351]	2.25 [0.089]

TABLE 2

No. OF POS. PER ROW	"A"	"B"	"C"	"D"	"E"	"F"
-10	13.84 [0.545]	10.48 [0.413]	7.20 [0.283]	10.56 [0.416]	9	7.200 [0.2835]
-20	21.84 [0.860]	18.48 [0.728]	15.20 [0.598]	18.56 [0.731]	19	15.200 [0.5984]
-30	29.84 [1.175]	26.48 [1.043]	23.20 [0.913]	26.56 [1.046]	29	23.200 [0.9134]
-40	37.84 [1.490]	34.48 [1.357]	31.20 [1.228]	34.56 [1.361]	39	31.200 [1.2283]
-50	45.84 [1.805]	42.48 [1.672]	39.20 [1.543]	42.56 [1.676]	49	39.200 [1.5433]

TABLE 1

SEAF8 LEAD STYLE	SEAM8 LEAD STYLE	
	-S02.0	-S05.0
-05.0	7.0	10.0

FIG 1 (SEAF8-30-05.0-XXX-08-X-K SHOWN) (SOME CENTER FEATURES REMOVED FOR CLARITY)

- NOTES:
- ⊗ REPRESENTS A CRITICAL DIMENSION.
 - MINIMUM PUSH OUT FORCE: -2 SOLDER COMPOSITION = 1.6N [0.36LBS] & -1/-3 SOLDER COMPOSITION = 1.2N [0.27LBS]
 - DIMENSION TO BE MEASURED IN ALL FOUR CORNERS TO THE STAND-OFF.
 - TAPE & REEL IS STANDARD PACKAGING.
 - NOTE DELETED.
 - NOTE DELETED.
 - NOTE DELETED.
 - MAXIMUM ROW TO ROW VARIATION 0.08 [0.003], MEASURED FIRST AND LAST POSITIONS ONLY, ALL ROWS.
 - CENTER MACHINE LUGS ON -40, -50 & -60 POSITIONS ONLY.
 - 8 & 10 ROWS ARE RELEASED FOR NITROGEN ENVIRONMENT PROCESSING ONLY. NOT RECOMMENDED FOR AIR ONLY PROCESSING.
 - K DOT WILL BE SUPPLIED WHETHER OR NOT -K IS SPECIFIED.
 - MEASURE DIMENSION OFF PEAK OF SOLDER CHARGE END.
 - ORDERS WILL BE PACKAGED ACCORDING TO THE SAMTEC PACKAGING EFFICIENCY STANDARDS (SPES) FOUND ON WWW.SAMTEC.COM.
 - ATTACH LABEL -4x2 TO EACH REEL.

UNLESS OTHERWISE SPECIFIED, DIMENSIONS ARE IN MILLIMETERS [INCHES].

PROPRIETARY NOTE
THIS DOCUMENT CONTAINS CONFIDENTIAL AND PROPRIETARY INFORMATION AND ALL DESIGN, MANUFACTURING, REPRODUCTION, USE, PATENT RIGHTS AND SALES RIGHTS ARE EXPRESSLY RESERVED BY SAMTEC, INC. THIS DOCUMENT SHALL NOT BE DISCLOSED, IN WHOLE OR PART, TO ANY UNAUTHORIZED PERSON OR ENTITY NOR REPRODUCED, TRANSFERRED OR INCORPORATED IN ANY OTHER PROJECT IN ANY MANNER WITHOUT THE EXPRESS WRITTEN CONSENT OF SAMTEC, INC.

TOLERANCES ARE:
DECIMALS: ANGLES:
X.X: ±0.3 [0.1] 2°
X.XX: ±0.13 [0.005]
X.XXX: ±0.051 [0.0020]

MATERIAL: DO NOT SCALE DRAWING SHEET SCALE: 2:1
INSULATOR: LCP, COLOR BLACK
CONTACT: COPPER ALLOY

F:\DWG\MISC\Mktg\SEAF8-XX-05.0-XXX-XX-X-X-MKT.SLDDRW

520 PARK EAST BLVD. NEW ALBANY, IN 47150
PHONE: 812-944-6733 FAX: 812-948-5047
e-Mail info@SAMTEC.com code 55322

DESCRIPTION:
0.8MM PITCH SOCKET ARRAY ASSY

DWG. NO.
SEAF8-XX-05.0-XXX-XX-X-X-XX

BY: M MURILLO 01/09/09 SHEET 1 OF 4

-2 SOLDER COMPOSITION & STYLE
SEAF8 BUILT WITH SUB-C-265-05.0-X-X
(SEE TABLE 6)

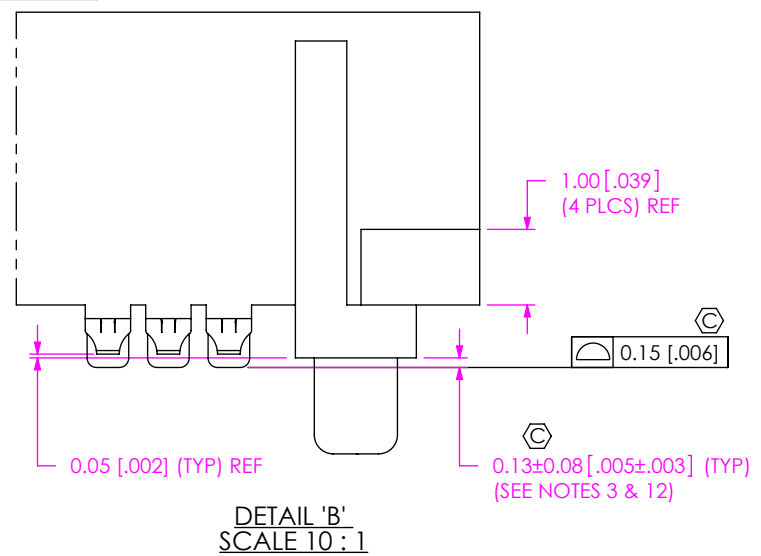
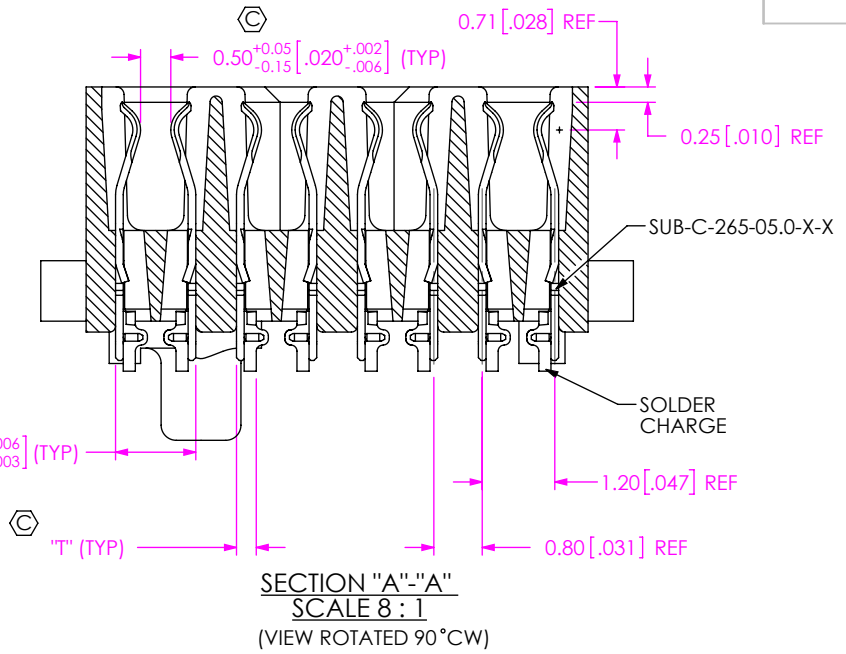

-1 & -3 SOLDER COMPOSITION & STYLE
SEAF8 BUILT WITH SUB-C-472-05.0-XXX-X
(SEE TABLE 6)

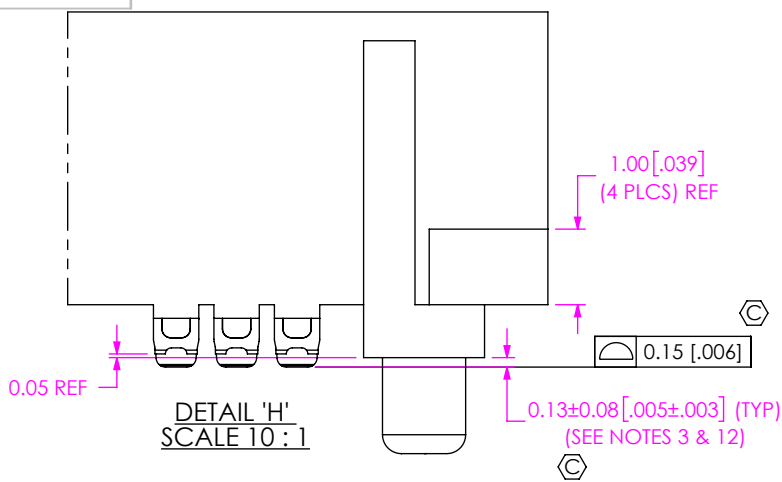
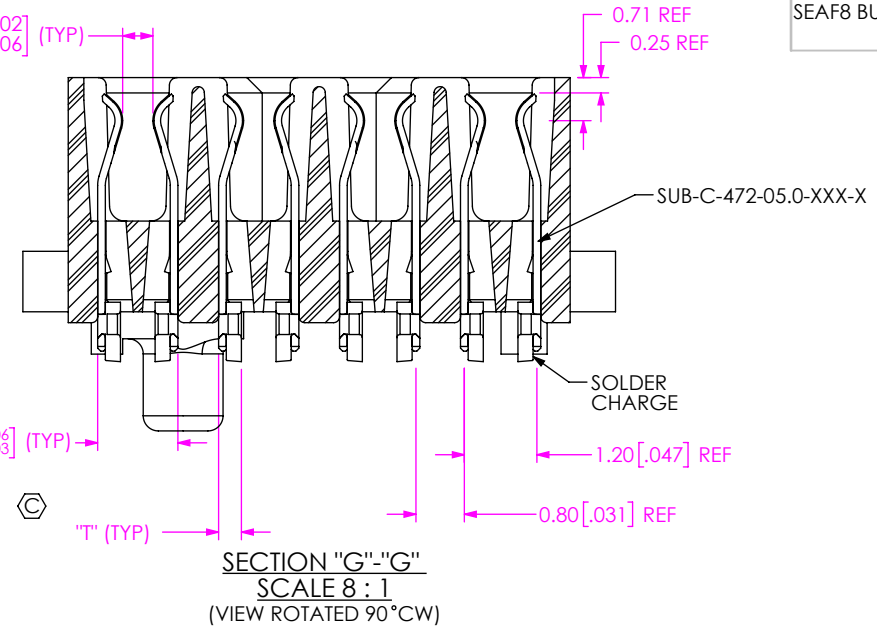

SOLDER STYLE	ROW	POSITION	CONTACT SUB ASSY	"T"
-1	ALL	ALL	SUB-C-472-05.0-XXX-1	0.38 [0.015]
-2	-04 THRU -10	-10 THRU -50	SUB-C-265-05.0-X-2	0.33 [0.013]
-3	ALL	ALL	SUB-C-472-05.0-XXX-2	0.38 [0.015]

PROPRIETARY NOTE
THIS DOCUMENT CONTAINS CONFIDENTIAL AND PROPRIETARY INFORMATION AND ALL DESIGN, MANUFACTURING, REPRODUCTION, USE, PATENT RIGHTS AND SALES RIGHTS ARE EXPRESSLY RESERVED BY SAMTEC, INC. THIS DOCUMENT SHALL NOT BE DISCLOSED, IN WHOLE OR PART, TO ANY UNAUTHORIZED PERSON OR ENTITY NOR REPRODUCED, TRANSFERRED OR INCORPORATED IN ANY OTHER PROJECT IN ANY MANNER WITHOUT THE EXPRESS WRITTEN CONSENT OF SAMTEC, INC.

samtec
520 PARK EAST BLVD, NEW ALBANY, IN 47150
PHONE: 812-944-6733 FAX: 812-948-5047
e-Mail info@SAMTEC.com code 55322

DO NOT SCALE DRAWING
SHEET SCALE: 2:1

DESCRIPTION:
0.8MM PITCH SOCKET ARRAY ASSY
DWG. NO.
SEAF8-XX-05.0-XXX-XX-X-X-XX
BY: M MURILLO 01/09/09 SHEET 2 OF 4

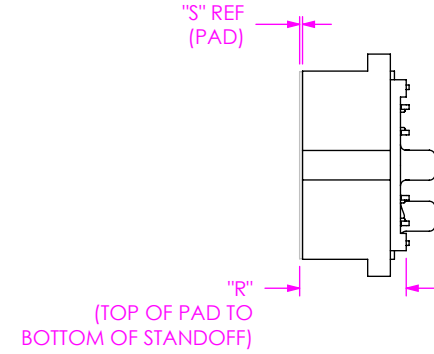
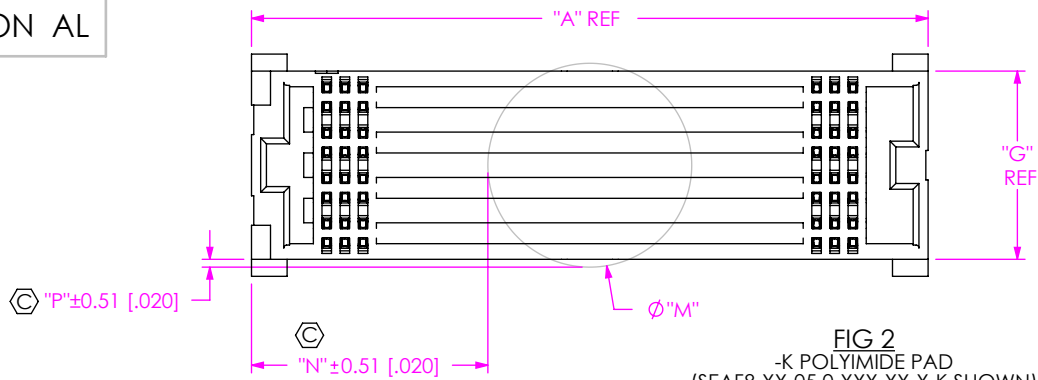

FIG 2
-K POLYIMIDE PAD
(SEAF8-XX-05.0-XXX-XX-X-K SHOWN)
(SOME CENTER FEATURES REMOVED FOR CLARITY)

-No. OF ROWS	K-DOT #	"S"
-04	K-DOT-.217-.313-.005	0.13 [.005]
-06	K-DOT-.295-.406-.005	0.13 [.005]
-08	K-DOT-.354-.469-.005	0.13 [.005]
-10	K-DOT-.460-.550-.005	0.13 [.005]

-No. OF ROWS	Ø "M"	"N"					"p"	"R"
		10 POS	20 POS	30 POS	40 POS	50 POS		
-04	5.51 [.217]	4.17 [.164]	8.17 [.321]	12.17 [.479]	16.17 [.636]	20.17 [.794]	0.61 [.024]	4.70 [.185]
-06	7.49 [.295]	3.18 [.125]	7.18 [.282]	11.18 [.440]	15.18 [.597]	19.18 [.755]	0.60 [.023]	4.70 [.185]
-08	8.99 [.354]	2.43 [.095]	6.43 [.253]	10.43 [.410]	14.43 [.568]	18.43 [.725]	0.35 [.014]	4.70 [.185]
-10	11.68 [.460]	1.08 [.043]	5.08 [.200]	9.08 [.357]	13.08 [.515]	17.08 [.672]	0.69 [.027]	4.70 [.185]

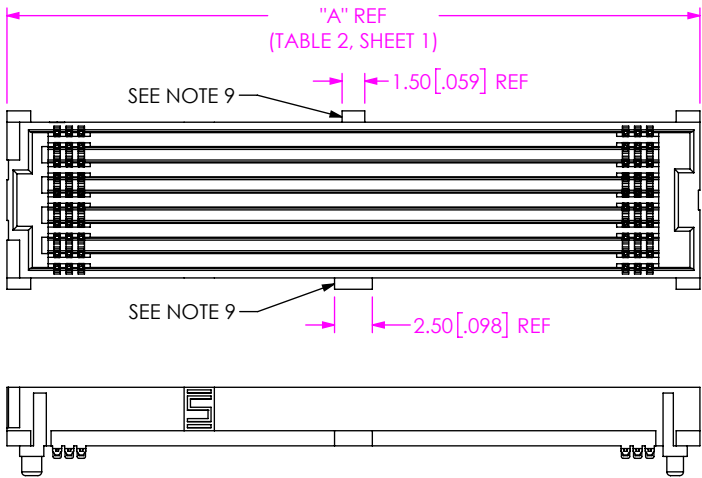
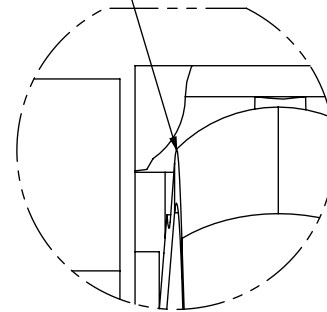
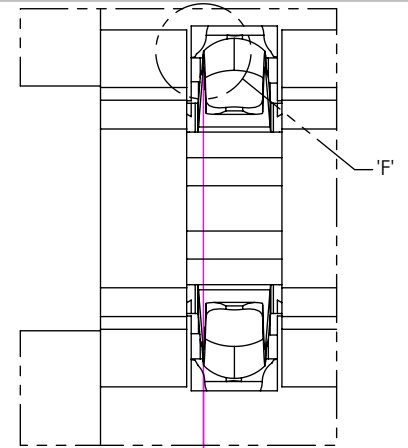

FIG 3
(SEAF8-50-05.0-XXX-10-X-K SHOWN)
(SOME CENTER FEATURES REMOVED FOR CLARITY)
(SAME AS FIG 1, EXCEPT AS SHOWN)

MEASUREMENTS TAKEN AT EDGE OF CONTACT



DETAIL 'F'
SCALE 100 : 1



0.10 [.004] MAX
(MEASURE FROM BEAM EDGES)

DETAIL 'C'
SCALE 30 : 1

F:\DWG\MISC\Mktg\SEAF8-XX-05.0-XXX-XX-X-X-XX-MKT.SLDDRW

PROPRIETARY NOTE
THIS DOCUMENT CONTAINS CONFIDENTIAL AND PROPRIETARY INFORMATION AND ALL DESIGN, MANUFACTURING, REPRODUCTION, USE, PATENT RIGHTS AND SALES RIGHTS ARE EXPRESSLY RESERVED BY SAMTEC, INC. THIS DOCUMENT SHALL NOT BE DISCLOSED, IN WHOLE OR PART, TO ANY UNAUTHORIZED PERSON OR ENTITY NOR REPRODUCED, TRANSFERRED OR INCORPORATED IN ANY OTHER PROJECT IN ANY MANNER WITHOUT THE EXPRESS WRITTEN CONSENT OF SAMTEC, INC.

DO NOT SCALE DRAWING

SHEET SCALE: 2:1

samtec

520 PARK EAST BLVD, NEW ALBANY, IN 47150
PHONE: 812-944-6733 FAX: 812-948-5047
e-Mail info@SAMTEC.com code 55322

DESCRIPTION:
0.8MM PITCH SOCKET ARRAY ASSY

DWG. NO.
SEAF8-XX-05.0-XXX-XX-X-X-XX

BY: M MURILLO 01/09/09 SHEET 3 OF 4

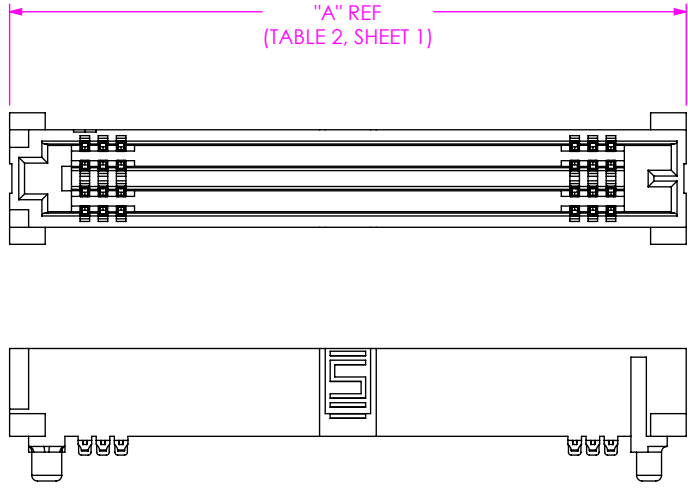

FIG 4
 (SEAF8-30-05.0-XXX-04-X-K SHOWN)
 (SOME CENTER FEATURES REMOVED FOR CLARITY)
 (SAME AS FIG 1, EXCEPT AS SHOWN)

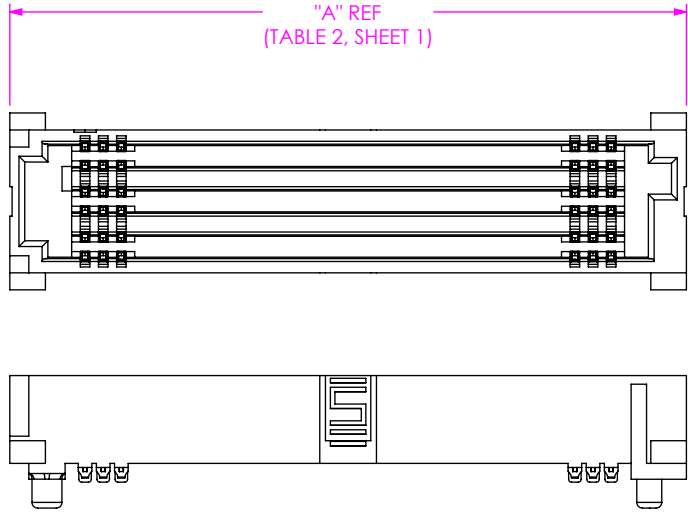



FIG 5
 (SEAF8-30-05.0-XXX-06-X-K SHOWN)
 (SOME CENTER FEATURES REMOVED FOR CLARITY)
 (SAME AS FIG 1, EXCEPT AS SHOWN)

<p>PROPRIETARY NOTE</p> <p>THIS DOCUMENT CONTAINS CONFIDENTIAL AND PROPRIETARY INFORMATION AND ALL DESIGN, MANUFACTURING, REPRODUCTION, USE, PATENT RIGHTS AND SALES RIGHTS ARE EXPRESSLY RESERVED BY SAMTEC, INC. THIS DOCUMENT SHALL NOT BE DISCLOSED, IN WHOLE OR PART, TO ANY UNAUTHORIZED PERSON OR ENTITY NOR REPRODUCED, TRANSFERRED OR INCORPORATED IN ANY OTHER PROJECT IN ANY MANNER WITHOUT THE EXPRESS WRITTEN CONSENT OF SAMTEC, INC.</p> <p>DO NOT SCALE DRAWING</p> <p>SHEET SCALE: 2:1</p>	 <p>520 PARK EAST BLVD, NEW ALBANY, IN 47150 PHONE: 812-944-6733 FAX: 812-948-5047 e-Mail info@SAMTEC.com code 55322</p>	
	<p>DESCRIPTION: 0.8MM PITCH SOCKET ARRAY ASSY</p>	
	<p>DWG. NO. SEAF8-XX-05.0-XXX-XX-X-X-XX</p>	
	<p>BY: M MURILLO</p>	<p>01/09/09</p>