

THIS IS A C.A.D. GENERATED DRAWING
DO NOT MAKE MANUAL REVISIONS TO MASTER.

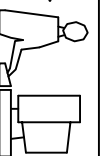

ISSUE NUMBER
ORIGINAL

①

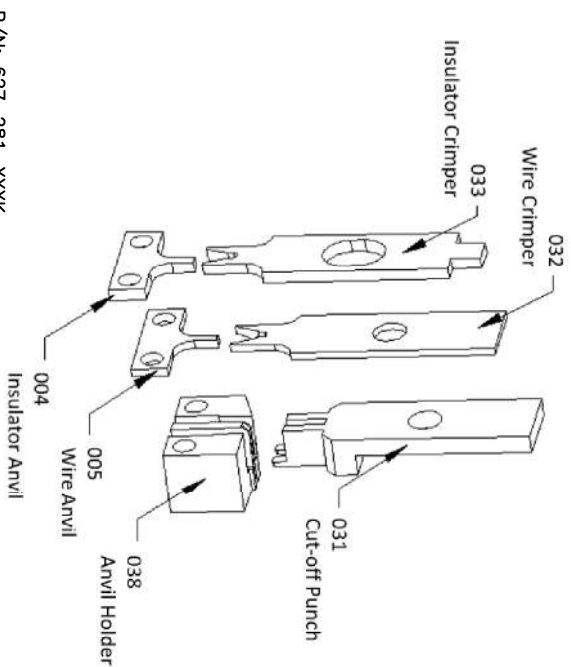
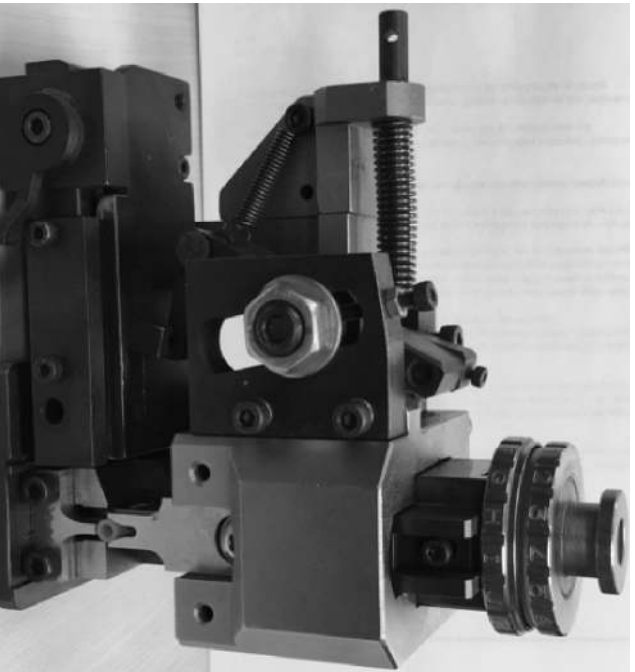

P/N: 627-281-XXXX

| | |
|---------------|-----------|
| PRESS TYPE | K PRESS |
| STROKE LENGTH | 30.00 MM |
| SHUT HEIGHT | 119.55 MM |
| AWG | 20-28 |

| REPLACEMENT PUNCH & DIE PARTS | | | | | |
|-------------------------------|--------------|--------------|-------------------|---------------|--------------|
| INSULATOR ANVIL | WIRE ANVIL | WIRE CRIMPER | INSULATOR CRIMPER | CUT OFF PUNCH | ANVIL HOLDER |
| 627-281-004K | 627-281-005K | 627-281-032K | 627-281-033K | 627-281-031K | 627-281-038K |

NOTES:

- 1- THIS APPLICATOR IS DESIGNED TO BE USED ON A K CRIMPING MACHINE.
- 2- THIS APPLICATOR IS DESIGNED FOR CRIMPING EDAC CONTACT P/N 627-290-001.
- 3- FOR THE DEFINITION OF STROKE LENGTH AND SHUT HEIGHT, APPLICATOR SETUP AND OPERATING INSTRUCTION, PLEASE REFER TO DOCUMENT "APPLICATOR INSTRUCTION MANUAL K PRESS".

K PRESS APPLICATOR FOR 627-290-001

EDAC INC
TORONTO, ONTARIO
CANADA

THESE DRAWINGS AND SPECIFICATIONS ARE THE PROPERTY OF EDAC INC. AND SHALL NOT BE REPRODUCED, OR COPIED OR USED AS THE BASIS FOR THE MANUFACTURE OR SALE OF APPARATUS WITHOUT WRITTEN PERMISSION.

| | |
|--------------------|--------------|
| ACAD REFERENCE NO. | 627-280-751K |
| DRAWN: | K.L. |
| CHECKED: | R.S.M. |
| SCALE: | N.T.S. |
| DRAWING NUMBER | 627-280-751K |
| DATE: | OCT.29/2020 |
| DATE: | OCT.29/2020 |
| SHEET | 1 OF 1 |
| ISSUE | 1 |