

Development Board EPC9040 Quick Start Guide

EPC2104

Monolithic Half-Bridge with Gate Drive

Revision 1.0

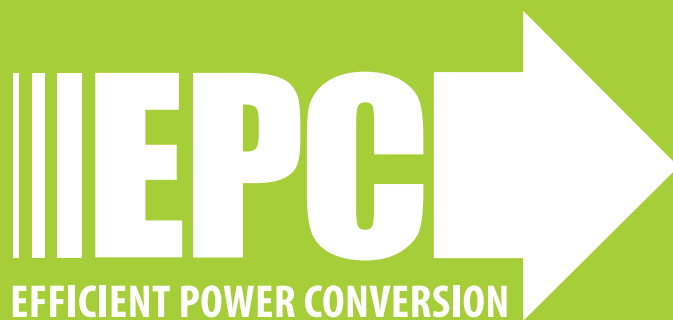

DESCRIPTION

These development boards are in a monolithic half bridge topology with onboard gate drives, featuring the EPC2104 eGaN/IC (Enhancement-mode Gallium Nitride Integrated Circuits). The purpose of these development boards is to simplify the evaluation process of these monolithically integrated eGaN FETs by including all the critical components on a single board that can be easily connected into any existing converter.

The development board is 2" x 2" and contains one eGaN/IC in half bridge configuration using the Texas Instruments LM5113 gate driver, supply and bypass capacitors. The board contains all critical components and layout for optimal switching performance and has additional area to add buck output filter components on board. There are also various probe points to facilitate simple waveform measurement and efficiency calculation. A complete block diagram of the circuit is given in Figure 1.

For more information on the EPC2104 eGaN/IC, please refer to the datasheets available from EPC at www.epc-co.com. The datasheet should be read in conjunction with this quick start guide.

SETUP AND OPERATION

The development boards are easy to set up to evaluate the performance of the eGaN/IC. The board allows the on-board placement of buck output filter components. Refer to Figure 2 for proper connect and measurement setup and follow the procedure below:

1. With power off, connect the input power supply bus to +V_{IN} (J5, J6) and ground / return to -V_{IN} (J7, J8).
2. With power off, connect the switch node of the half bridge OUT (J3, J4) to your circuit as required.
3. With power off, connect the gate drive input to +V_{DD} (J1, Pin-1) and ground return to -V_{DD} (J1, Pin-2).
4. With power off, connect the input PWM control signal to PWM (J2, Pin-1) and ground return to any of the remaining J2 pins.
5. Turn on the gate drive supply – make sure the supply is between 7 V and 12 V range.
6. Turn on the bus voltage to the required value (do not exceed the absolute maximum voltages).
7. Turn on the controller / PWM input source and probe switching operation.
8. Once operational, adjust the bus voltage and load PWM control within the operating range and observe the output switching behavior, efficiency and other parameters.
9. For shutdown, please follow steps in reverse.

NOTE. When measuring the high frequency content switch node (OUT), care must be taken to avoid long ground leads. Measure the switch node (OUT) by placing the oscilloscope probe tip through the large via on the switch node (designed for this purpose) and grounding the probe directly across the GND terminals provided. See Figure 3 for proper scope probe technique.

Table 1: Performance Summary (T_A = 25°C) EPC9040

Symbol	Parameter	Conditions	Min	Max	Units
V _{DD}	Gate Drive Input Supply Range		7	12	V
V _{IN}	Bus Input Voltage Range			60*	V
V _{OUT}	Switch Node Output Voltage			60*	V
I _{OUT}	Switch Node Output Current			15**	A
V _{PWM}	PWM Logic Input Voltage Threshold	Input 'High'	3.5	6	V
		Input 'Low'	0	1.5	V
	Minimum 'High' State Input Pulse Width	V _{PWM} rise and fall time < 10ns	50		ns
	Minimum 'Low' State Input Pulse Width	V _{PWM} rise and fall time < 10ns	100#		ns

*Maximum input voltage depends on inductive loading.

** Maximum current depends on die temperature – actual maximum current will be subject to switching frequency, bus voltage and thermal cooling. Symmetrical eGaN intended for 50% duty cycle or low step-down ratio applications.

Limited by time needed to 'refresh' high side bootstrap supply voltage.

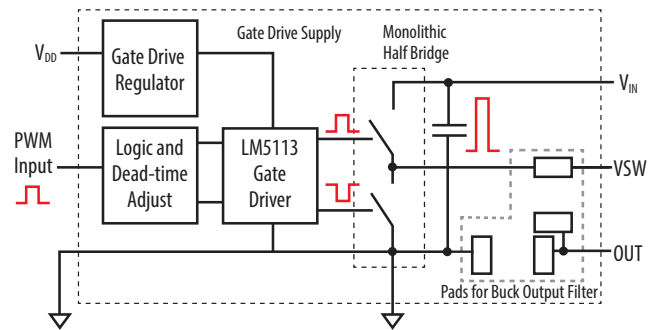

Figure 1: Block Diagram of Development Board

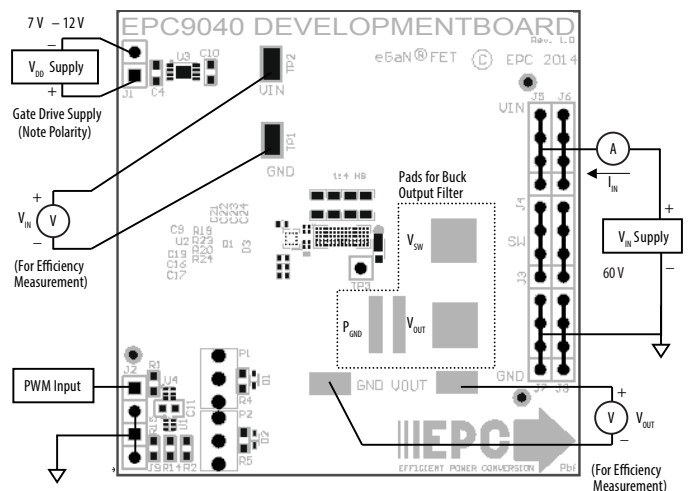

Figure 2: Proper Connection and Measurement Setup

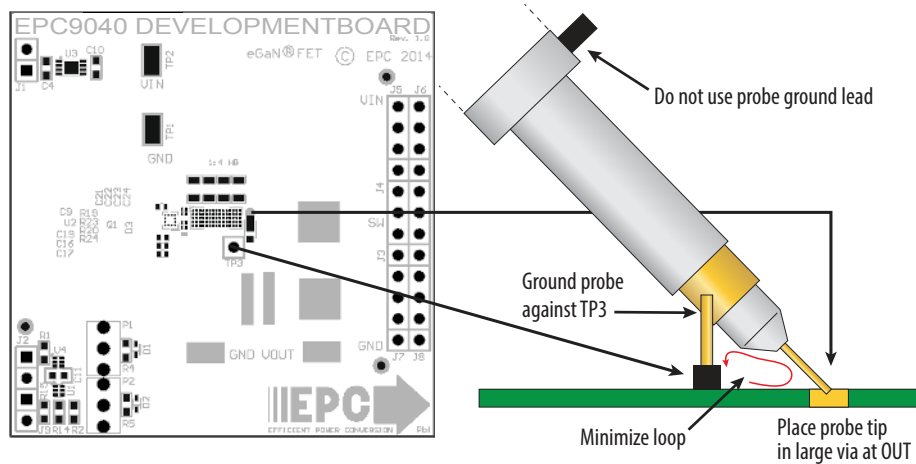

Figure 3: Proper Measurement of Switch Node – OUT

THERMAL CONSIDERATIONS

The EPC9040 development boards showcase the EPC2104 eGaNiC. These development boards are intended for bench evaluation with low ambient temperature and convection cooling. The addition

of heat-sinking and forced air cooling can significantly increase the current rating of these devices, but care must be taken to not exceed the absolute maximum die temperature of 150°C.

NOTE: These development boards do not have any current or thermal protection on board.

Table 2: Bill of Material

Item	Qty	Reference	Part Description	Manufacturer / Part#
1	3	C4, C10, C11,	Capacitor, 1 μ F, 10%, 25 V, X5R	Murata, GRM188R61E105KA12D
2	2	C16, C17	Capacitor, 100 pF, 5%, 50 V, NP0	Kemet, C0402C101K5GACTU
3	2	C9, C19	Capacitor, 0.1 μ F, 10%, 25 V, X5R	TDK, C1005X5R1E104K
4	4	C21, C22, C23, C24	Capacitor - 1 μ F, 10%, 100 V, X7S	TDK, CGA4J3X7S2A105K125AE
5	2	D1, D2	Schottky Diode, 30 V	Diodes Inc., SDM03U40-7
6	3	J1, J2, J9	Connector	2 pins of Tyco, 4-103185-0
7	6	J3, J4, J5, J6, J7, J8	Connector	FCI, 68602-224HLF
8	1	Q1	eGaNiC	EPC2104
9	1	R1	Resistor, 10.0 k, 5%, 1/8 W	Stackpole, RMCF0603FT10K0
10	2	R2, R15	Resistor, 0 Ω , 1/8 W	Stackpole, RMCF0603ZTOR00
11	1	R4	Resistor, 47 Ω , 1%, 1/8W	Stackpole, RMCF0603FT47R0
12	1	R5	Resistor, - 75 Ω , 1%, 1/8W	Stackpole, RMCF0603FT75R0
13	4	R19, R20, R23, R24	Resistor, 0 Ω , 1/20 W	Panasonic, ERJ-1GE0R00C
14	2	TP1, TP2	Test Point	Keystone Elect, 5015
15	1	TP3	Connector	1/40th of Tyco, 4-103185-0
16	1	U1	I.C., Logic	Fairchild, NC7SZ00L6X
17	1	U2	I.C., Gate driver	Texas Instruments, LM5113
18	1	U3	I.C., Regulator	Microchip, MCP1703T-5002E/MC
19	1	U4	I.C., Logic	Fairchild, NC7SZ08L6X
20	0	R14	Optional Resistor	
21	0	D3	Optional Diode	
22	0	P1, P2	Optional Potentiometer	

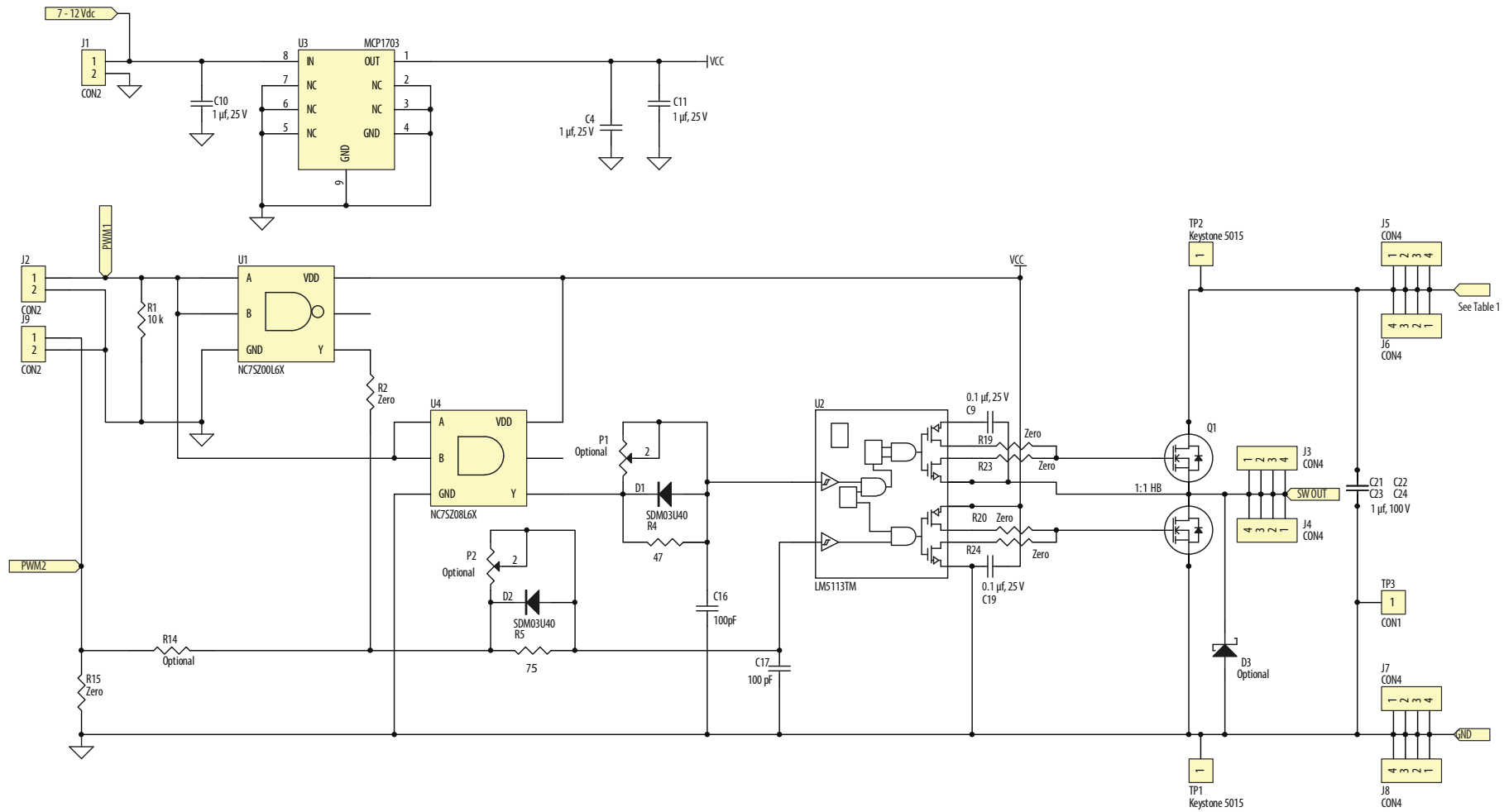

Figure 4: EPC9040 Development Board Schematic

For More Information:

Please contact info@epc-co.com
or your local sales representative

Visit our website:
www.epc-co.com

Sign-up to receive
EPC updates at
bit.ly/EPCupdates
or text "EPC" to 22828



EPC Products are distributed through Digi-Key.
www.digikey.com

Demonstration Board Notification

The EPC9040 board is intended for product evaluation purposes only and is not intended for commercial use. Replace components on the Evaluation Board only with those parts shown on the parts list (or Bill of Materials) in the Quick Start Guide. Contact an authorized EPC representative with any questions.

This board is intended to be used by certified professionals, in a lab environment, following proper safety procedures. Use at your own risk.

As an evaluation tool, this board is not designed for compliance with the European Union directive on electromagnetic compatibility or any other such directives or regulations. As board builds are at times subject to product availability, it is possible that boards may contain components or assembly materials that are not RoHS compliant. Efficient Power Conversion Corporation (EPC) makes no guarantee that the purchased board is 100% RoHS compliant.

The Evaluation board (or kit) is for demonstration purposes only and neither the Board nor this Quick Start Guide constitute a sales contract or create any kind of warranty, whether express or implied, as to the applications or products involved.

Disclaimer: EPC reserves the right at any time, without notice, to make changes to any products described herein to improve reliability, function, or design. EPC does not assume any liability arising out of the application or use of any product or circuit described herein; neither does it convey any license under its patent rights, or other intellectual property whatsoever, nor the rights of others.