

PRODUCT NO.

SEE SHEET 4

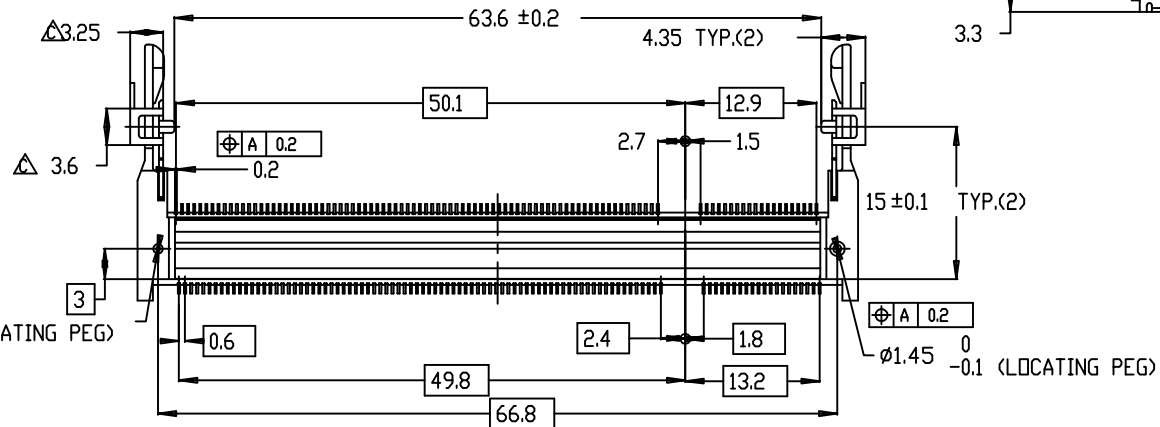
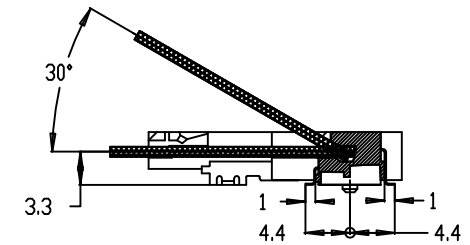
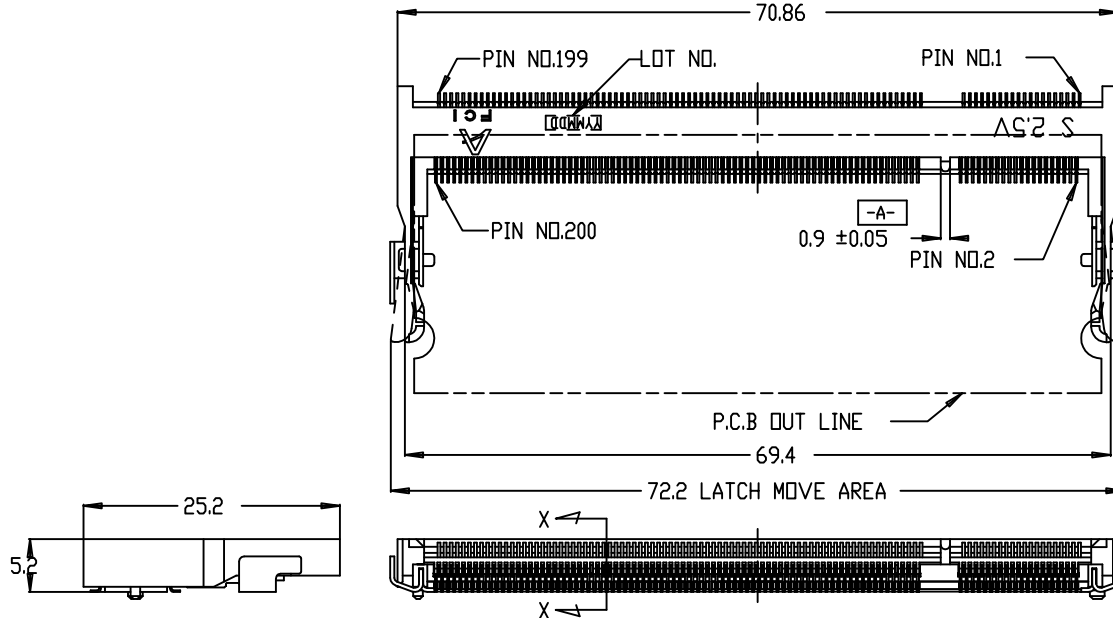

NOTE

1. PRODUCT SPEC. : GS-12-195
2. PACKAGING SPEC. : GS-14-786
3. MATERIAL
 - 1) HOUSING : LCP, UL94V-0, COLOR BLACK
 - 2) CONTACT : PHOSPHOR BRONZE
 - 3) HOLD DOWN : BRASS
4. FINISH
 - 1) TERMINAL : SEE TABLE
 - 2) HOLD DOWN : SEE TABLE
5. CO-PLANARITY : 0.1 MAX.(INCLUDE HOLD DOWN)
6. THIS PRODUCT MEETS EUROPEAN UNION DIRECTIVES AND OTHER COUNTRY REGULATIONS AS DESCRIBED IN GS-22-008.
7. THE HOUSING WILL WITHSTAND EXPOSURE TO 260° PEAK TEMPERATURE FOR 10 SECONDS IN A REFLOW SOLDER APPLICATION.

mat'l code				tolerances unless otherwise specified				CUSTOMER COPY	www.fgiconnect.com				
ltr	ecn no	dr	date	linear		.X ± 0.38/.015		projection	title				
A	DG06-0183	C S	05-12-06	.XX ± 0.25/.010		DDR SO-DIMM 0.6mm PITCH 200P STANDARD TYPE ASS'Y							
B	DG06-0535	C S	12/14/06	.XXX ± 0.15/.005		product family DDR							
C	DG08-0333	B L	12/01/08	angles		0° ± 2°			size dwg no		code	sheet	
				dr	CHARLIE S	05/12/06'	A4		10069102	1 of 4			
				engr	CHARLIE S	05/12/06'	scale						
				chr	BEER FU	05/12/06'	1:1						
				appd	JOESPH HSIA	05/12/06'							
sheet index	revision sheet	C	C	C	C	C	C						
		1	2	3	4								

Tous droits strictement reserves. Reproduction ou communication a des tiers interdite sous quelque forme que ce soit sans autorisation ecrite du Propriete de c FCI. Droits de reproduction FCI.



All rights strictly reserved. Reproduction or issue to third parties in any form whatever is not permitted without written authority from the proprietor. Property of FCI. Copyright FCI.

PRODUCT NO.
10069102-*****

Tous droits strictement reserves. Reproduction ou communication a des tiers interdite sous quelque forme que ce soit sans autorisation ecrite du Propriete de c FCI. Droits de reproduction FCI.



All rights strictly reserved. Reproduction or issue to third parties in any form whatever is not permitted without written authority from the proprietor. Property of FCI. Copyright FCI.

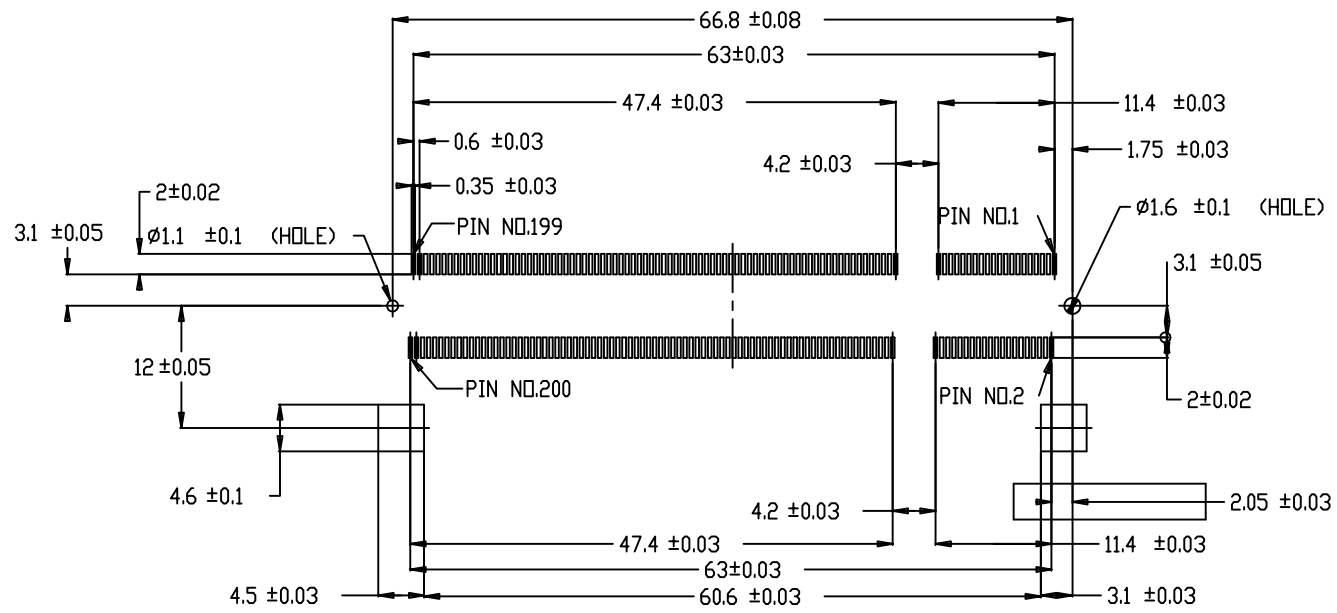

RECOMMENDED MOUNTING P.C.B LAYOUT

mat'l code				tolerances unless otherwise specified				CUSTOMER COPY		 www.fciconnect.com		
ltr	ecn no	dr	date	linear	.X ± 0.38/.015		projection	title				
C					.XX ± 0.25/.010			 MM	DDR SO-DIMM 0.6mm PITCH 200P			
					.XXX ± 0.15/.005				STANDARD TYPE ASSY			
				angles	0° ±2°			product family		DDR	code	
				dr	CHARLIE S	05/12/06'		size		dwg no	DG	
				enr	CHARLIE S	05/12/06'		A4		10069102	sheet	
				chr	BEER FU	05/12/06'	scale				2 of 4	
				appd	JOESPH HSIA	05/12/06'	1:1					
sheet index	revision sheet											

Tous droits strictement reserves. Reproduction ou communication a des tiers interdite sous quelque forme que ce soit sans autorisation ecrite du proprietaire. Propriete de c FCI. Droits de reproduction FCI.



All rights strictly reserved. Reproduction or issue to third parties in any form whatever is not permitted without written authority from the proprietor. Property of FCI. Copyright FCI.

PRODUCT NO.
10069102-*****

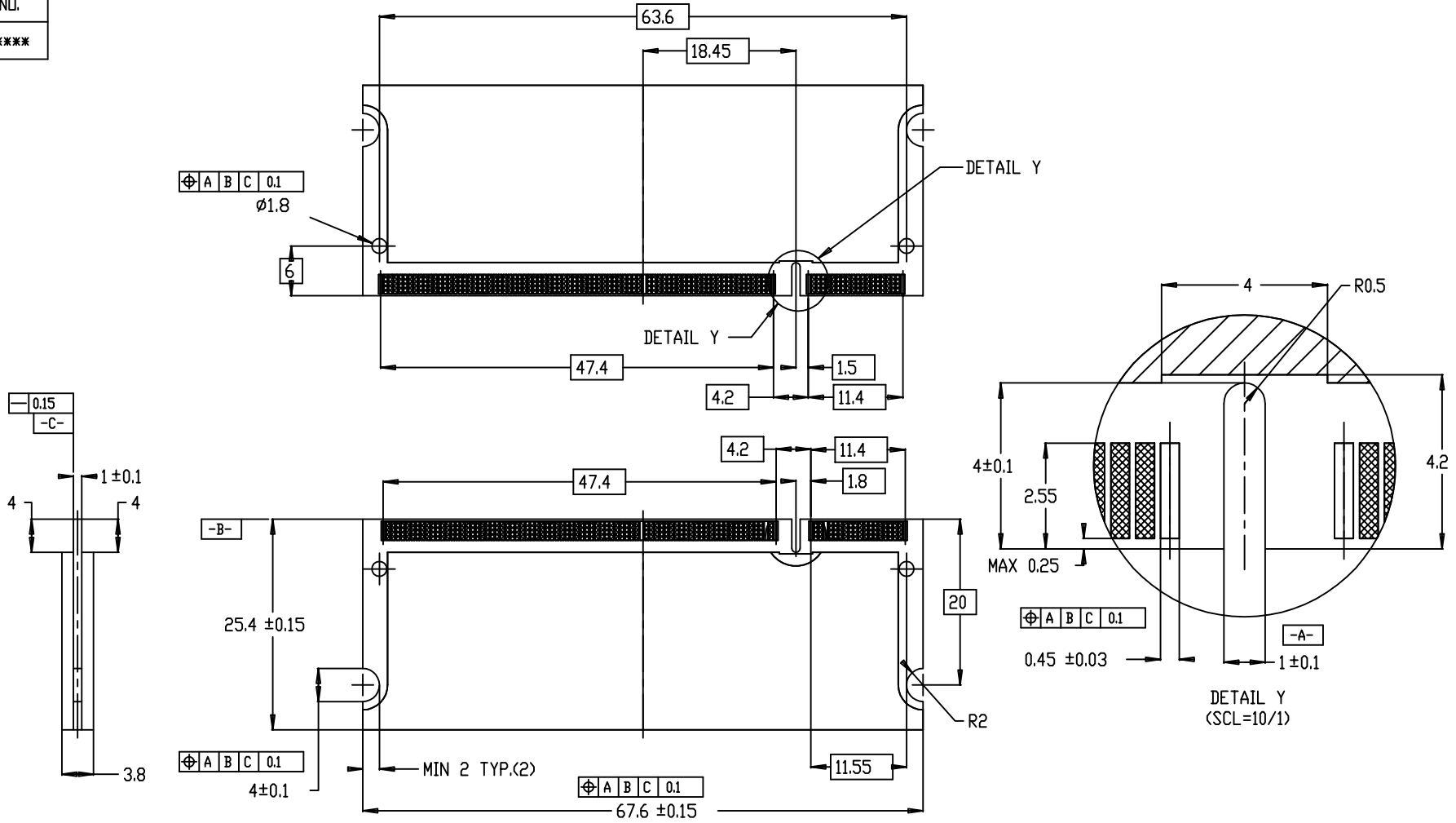

RECOMMENDED MODULE P.C.B. LAYOUT

mat'l code				tolerances unless otherwise specified				CUSTOMER COPY		 www.fciconnect.com	
ltr	ecn no	dr	date	linear	.X ± 0.38/.015		projection	title			
C					.XX ± 0.25/.010			DDR SO-DIMM 0.6mm PITCH 200P			
					.XXX ± 0.15/.005			STANDARD TYPE ASS'Y			
				angles	0° ± 2°		 MM	product family		DDR	code
				dr	CHARLIE S	05/12/06'		size		dwg no	DG
				engr	CHARLIE S	05/12/06'		A4		10069102	sheet
				chr	BEER FU	05/12/06'		1:1			3 of 4
				appd	JOESPH HSIA	05/12/06'					
sheet index	revision sheet										

Tous droits strictement réservés. Reproduction ou communication a des tiers interdite sous quelque forme que ce soit sans autorisation écrite du propriétaire de c FCI. Droits de reproduction FCI.



All rights strictly reserved. Reproduction or issue to third parties in any form whatever is not permitted without written authority from the proprietor. Property of FCI. Copyright FCI.

PRODUCT NO.	LOCATING PEG	TERMINAL CONTACT AREA FINISH	HOLD DOWN FINISH	SOLDER TAIL FINISH
10069102-452FC	YES	Au FLASH	Sn-Pb PLATING	Sn-Pb PLATING
10069102-452AC	YES	Au 0.76um MIN.	Sn-Pb PLATING	Sn-Pb PLATING
10069102-252FSLF	YES	Au FLASH	Sn PLATING	Sn PLATING
10069102-252ASLF	YES	Au 0.76um MIN.	Sn PLATING	Sn PLATING

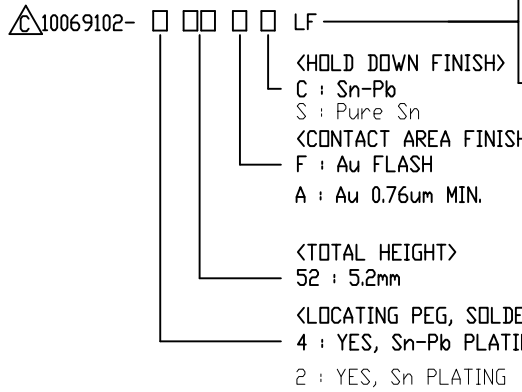

For Rohs OPTIONS:
 TAIL PLATING CODE MUST BE 0~3.
 HOLD DOWN PLATING CODE MUST BE 'S'.
 'LF' CODE IS EXIST IN THE END.
 EX: 10069102-252FSLF

FOR NOT Rohs COMPATIBLE:
 THIS 'LF' CODE IS 'BLANK'.
 EX:10069102-452FC

mat'l. code		tolerances unless otherwise specified		CUSTOMER COPY		 www.fciconnect.com		
ltr	ecn no	dr	date	linear	.X ± 0.38/.015	projection	 title DDR SD-DIMM 0.6mm PITCH 200P STANDARD TYPE ASS'Y	
C					.XX ± 0.25/.010			 MM
				angles	.XXX ± 0.15/.005			
				dr	CHARLIE S 05/12/06'	scale	product family DDR	
				eng	CHARLIE S 05/12/06'	1:1	code DG	
				chr	BEER FU 05/12/06'	A4	size dwg no	
				appd	JOESPH HSIA 05/12/06'	10069102	sheet 4 of 4	
sheet index	revision sheet							